

# VRI

## Plenum for Demand-Based Ventilation



- Supply air plenum for variable flow active diffusers VHB and VHD
- For optimised demand-based ventilation installations
- Guarantee of proper function of the supply air diffuser
- Airtight and robust construction with aesthetic design
- Effective sound attenuation
- Access for ductwork cleaning
- Junction box for cabling an active diffuser as standard with the delivery
- Detachable measurement and airflow adjustment module MSM

### MATERIAL AND FINISHING

PART	MATERIAL	NOTE
Casing	Galvanised steel	
Collar	Galvanised steel	
Attenuation material	Polyester fibre	
Spigot with gasket	Galvanised steel	Gasket of rubber compound
Measurement and adjustment module MSM	Body; Aluminium Plate; galvanised steel Brackets; galvanised steel Plastic parts; Polypropylene (PP) Spindle; Stainless steel	
Junction box	Plastic	
Hanging and safety wire	Steel	

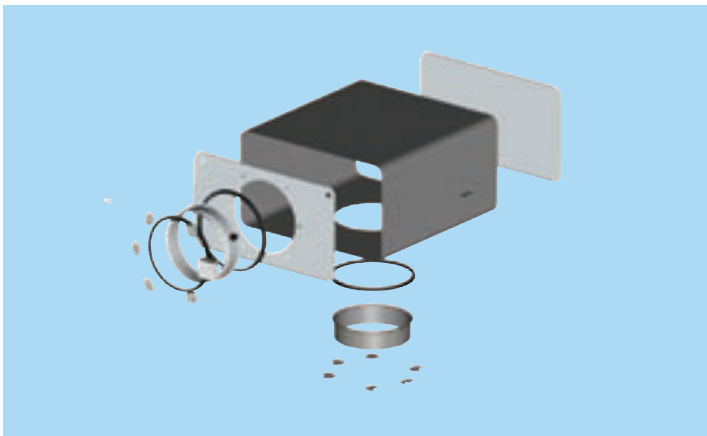
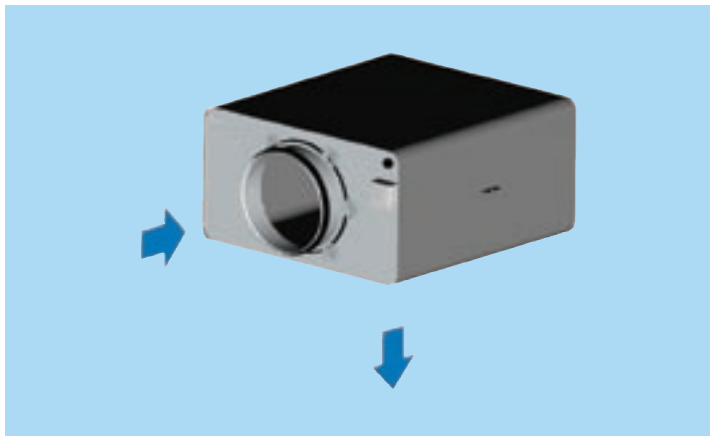

**Function**

The VRI balancing plenum equalises the airflow by reducing the flow velocity.  
 Air is spread evenly into the diffuser, ensuring a proper throw pattern in the room space.  
 The balancing plenum attenuates airborne sounds.

**Wiring**

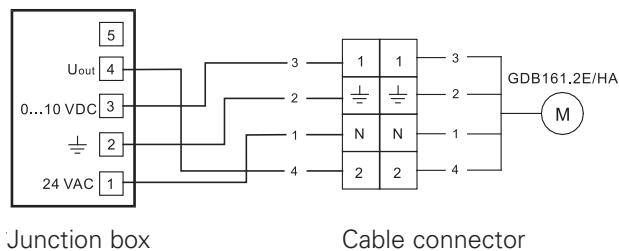

Control signals in junction box

Terminal 3  
 0 VDC = minimum position / airflow  
 10 VDC = maximum position / airflow

Terminal 5  
 Not connected

**DIMENSIONS**

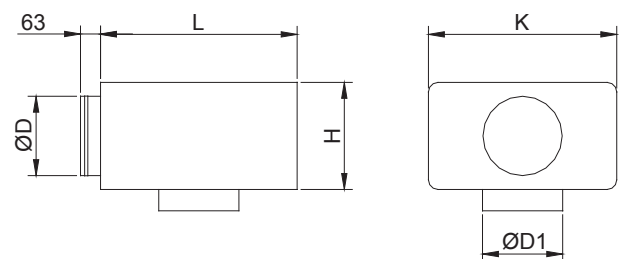

**Installation**

VRI plenum can be installed using two strips.  
 Connection to distribution ductwork is performed with a spigot including an integral gasket. VRI/V includes a pressure test plug.

**VRI/V**

The VRI/V is connected to the ventilation ductwork with a male inlet connection.  
 After the ductwork pressure test, the diffuser can be installed.  
 Hang the diffuser to the wire of the VRI/V plenum.  
 Connect the actuator cable connector plug to the plug from the plenum junction box.  
 Fix the actuator assembly to the plenum and tighten two screws.  
 The power supply and control signal cables are connected to junction box according to the diffuser's wiring instructions.

VRI / V, mm

NS	L	H	K	ØD	ØD1
125/160	458	182	432	124	162
160/160	458	222	432	159	162
200/200	618	272	592	199	202
250/250	618	336	592	249	252

For pressure drop and sound data, please refer to TRI.

**Adjustment**

The supply airflow rate is determined using measurement and adjustment module MSM. Maximum airflow rate is measured when the active diffuser is fully open. Pull out the airflow measurement tubes and airflow adjustment spring through the plenum. Make sure that the active diffuser is fully open. Measure the differential pressure with a manometer and calculate the airflow rate using the formula below.

$$q_v = k * \sqrt{\Delta p_m}$$

- q<sub>v</sub>      actual airflow rate, l/s
- k          airflow coefficient: see the k value table delivered with the diffuser
- ΔP<sub>m</sub>    measured differential pressure

Adjust the airflow rate by rotating the adjustment spring until the desired setting is achieved. Push the tubes and adjustment spring back into the plenum.

**Servicing**

Open the diffuser part and detach the perforated plate of the coupling sleeve. Remove the control cone part completely by opening the screw in the middle of the cone.

Loosen two screws which are holding the motor assembly on VHB body and let it hang on the wire. The MSM is removed through VRI/V outlet by pulling from it's body - not the measurement tubes or control spindle.

The possible sound attenuation material of the plenum is removable and washable.

Clean the parts with a damp cloth, instead of immersing in water.

Replace all parts in opposite order.

Both the diffuser and the airflow adjustment unit are removable for ductwork cleaning purposes.

Open or detach the diffuser.

Detach the measurement and adjustment module by gently pulling from the unit body. Please, do not pull from the adjustment spring or measurement tubes.

For cleaning of the plenum and diffuser, wipe the

plenum and diffuser parts with a damp cloth, instead of immersing in water.

The sound attenuation material of the plenum is removable and washable.

After cleaning, reassemble the sound attenuation material, airflow adjustment unit and diffuser.

**Suggested specifications**

The balancing plenum shall be made of galvanised steel and shall have an airtight design.

The airflow equalisation module or airflow rate measurement and adjustment module shall be supplied for supply air applications.

The measurement and adjustment module shall be adjustable without opening the device.

The balancing plenum shall have a spigot with integral gasket for airtight duct connection and a plug for ductwork pressure testing.

The balancing plenum shall attenuate airborne sound, and the sound attenuation material shall be made of polyester fibre with a washable surface.

**Product code**

VRI/S-D-E

S = VRI plenum  
           V           V model

D = Diameter of duct connection  
           160, 200, 250

E = Dimension of diffuser connection  
           D=160: 160  
           D=200: 200  
           D=250: 250

Code example

VRI/V-160-160