

UTL-W, UTL-I

Utiline

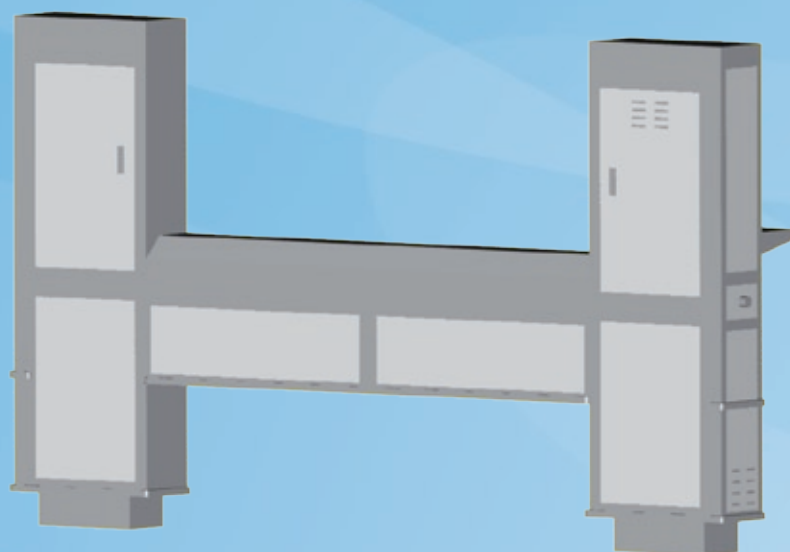

60/UTL-W,UTL-I/250/0106/EN

Modular system, standard range of components with or without services.

- Modular expandable design and construction
- Available as either a wall type unit (UTL-W) or island type (UTL-I)
- All integral pipework and electrical services pre-assembled and tested off site.
- Can be supplied with or without integral services
- Co-ordinated interface with ventilation products
- Fully accessible for easy cleaning and maintenance
- Total segregation of M & E Services
- A wide range of optional extras
- Inbuilt flexibility allowing ease of additions/changes
- Dedicated and or multi serviced users to suit each application
- Compatible with Unipoint range of SDU's

Application

Developed for use in commercial kitchens, the Utiline range of SDU's provides off the shelf components affording a cost effective way of distributing services to commercial cooking applications. The Utiline system is totally modular in its construction and is expandable to facilitate any cooking 'line up'. Pre-assembled off site, the Utiline eliminates the co-ordination of other trades, allowing a single point of connection for final 'hook up' to gas, water, electric etc.

Consultant Specification

Services distribution unit model Utiline_____ having overall dimensions of _____x250 x 1200/height to suit ventilation canopy/false or ventilated ceiling. (Delete as required).

Unit manufactured from 1.2mm thick (18g) stainless steel, fully formed, folded and welded (where applicable).

Unit comprising:

Electrical riser complete with range of rotary type isolators and electrical distribution board (Delete as required)

Mechanical riser - complete with side hinged door for access to valved services

Combined Elec/mech riser complete with range of rotary type isolators and electrical distribution board (Delete as required) and side hinged door for access to valved services. Services to be fully segregated throughout.

Horizontal raceway complete with lift off access panels (mechanical section) and conceal fixed removable sloping profile lid (electrical section)

Services fully segregated with all services being mechanically sealed.

Base of raceway fitted with range of interchangeable service plates to accommodate standard range of utility outlets.

Modifications & Options

- Incorporation of integrated Water Wash Control Panel*
- Incorporation of integrated Ecology Unit Control Panel*
- Incorporation of integrated Fire Suppression Control Panel*
- Incorporation of integrated Electrical Distribution Control Panel
- Gas Solenoid Valve
- Cantilevered shelf supports for high level equipment
- Fuel shut off facility
- Ventilation canopy lighting control
- Ventilation canopy Fan Control
- Cooking equipment flexible hoses/quick release assemblies
- Combined electrical/mechanical riser
- General purpose switched socket outlets
- Bumper rail

* Unipoint detailing applies

Model UTL-W - wall type

60/UTL-W,UTL-I/250/0106/EN

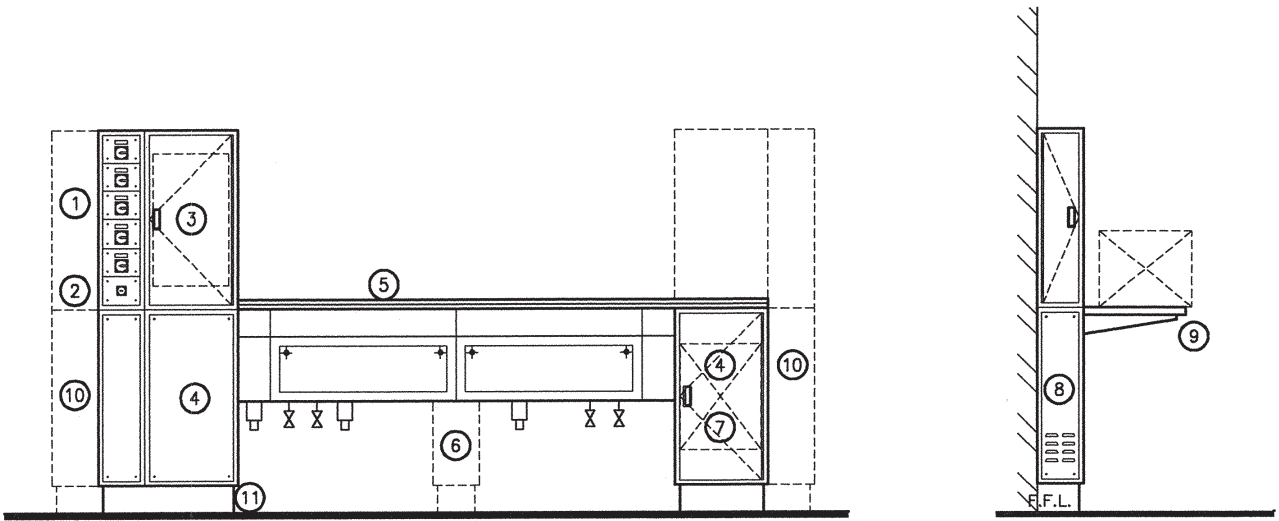

Island combinations

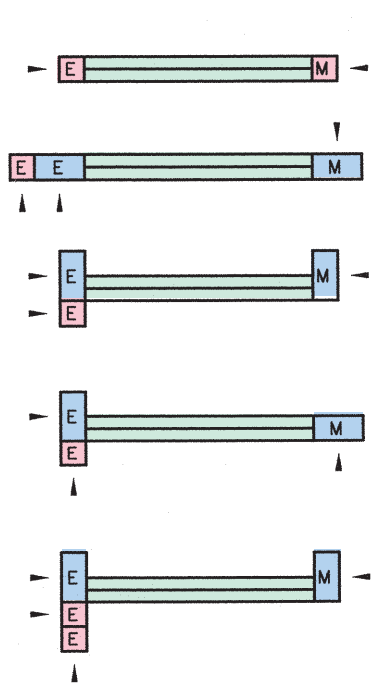

Wall combinations

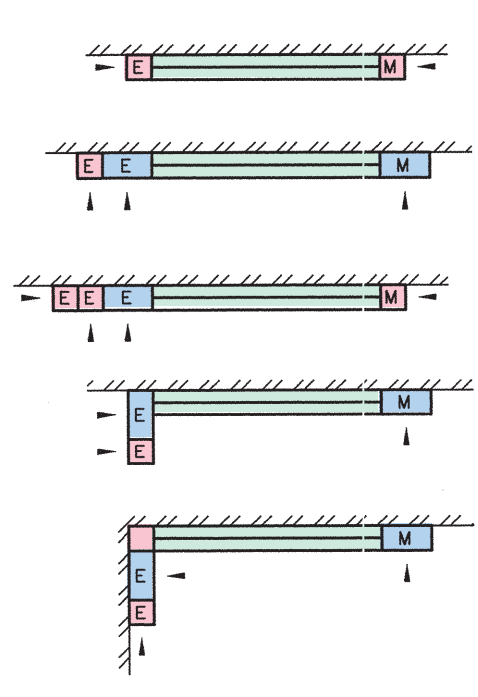

Service Options

Electric
gas
Cold water
Hot water (Flow & Return)

Utiline Options

- 1) Rotary Isolators
- 2) Emergency fuel shut off (optional)
- 3) Electrical Distribution Board (optional)
- 4) Access panels/doors
- 5) Concealed fixed sloping lid
- 6) Pedestal leg
- 7) Fire Suppression System (optional)
- 8) Ventilated access panels/doors
- 9) Cantilevered Equipment supports
- 10) Outline of fiser options

The company has a policy of continuous product development, therefore we reserve the right to modify

design and specifications without notice. Utiline is a registered trademark of Halton Vent Master Ltd.