

# FDV

Fire Valve



- Combined exhaust valve and fire damper for circular ducts
- Type-approved unit compliant with the EN 1366-2 and EN 13501-3 standards
- Fire resistance class ES120/EIS15 for installations on a lightweight plasterboard, lightweight concrete, concrete and masonry walls
- Fire resistance class ES120/EIS30 on concrete slabs
- Fuse release temperature of 50, 72, or 100 °C
- Manufacture in accordance with an ISO 9001 quality management system
- External quality control by the Technical Research Centre of Finland, VTT

## MATERIAL AND FINISHING

PART	MATERIAL	NOTE
Collar	Steel	Epoxy painted
Central cone	Steel	Epoxy painted
Frame gasket	Polyurethane	
Fireproof gasket	Silicate	
Installation frame	Galvanised steel	
Melting fuse	Brass	

## DIMENSIONS AND WEIGHT

NS	ØW	H	ØD
100	139	88	99
125	165	88	124
160	200	88	159
200	251	86	199

NS	Weight
100	0.40
125	0.53
160	0.72
200	1.03

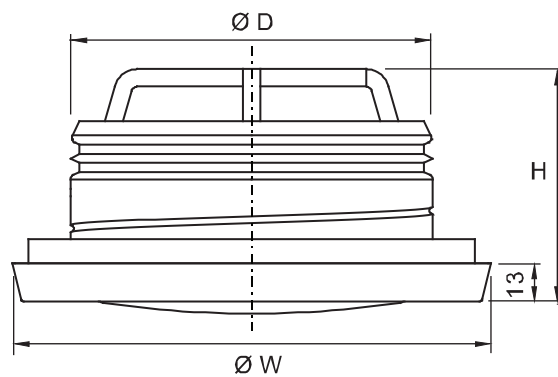

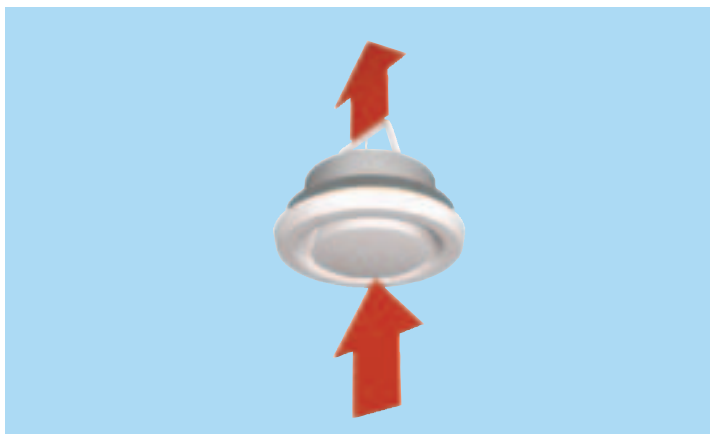

## Function

The FDV is a circular fire valve. It prevents fire and smoke from spreading in ventilation ducts.

### Operation as an exhaust valve – normal mode

The valve throttles the exhaust air flow and attenuates the duct noise. The pressure drop is dependent on the position of the central cone. The desired exhaust rate is set during the balancing of the air flows in a ductwork system.

### Operation as a fire damper – emergency mode

The fire damper contains an integral thermal fuse. This fuse responds to a rise in temperature, which causes a spring-return central cone to close.

The thermal fuse is released at 50°C, 72°C, or 100°C.

## Installation

1. Lightweight wall
2. Concrete or masonry wall or ceiling
3. Fire-stop mass (Würth Firebreak 22)
4. Screws

The fire valve is approved for installation on concrete or masonry walls and ceilings and on lightweight walls.

Make an opening in the separating element for the air duct to be led through the structure. The size of the installation opening is  $D + 20$  mm.

Install the duct in the opening. Create the fire seal between duct and wall with a fire-stop mass (Würth Firebreak 22) and rockwool as indicated in the picture. Cut the duct flush with the wall surface.

Push the installation frame into the duct so that the flange is firmly pressed against the wall surface. Attach the installation to the duct and wall with two screws.

Push the valve (2) into the installation frame(1), and turn until it is firmly attached.

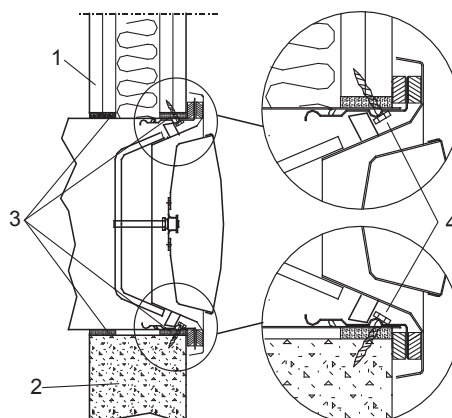

Detailed installation instructions, as well as an installer's installation certificate form, are supplied with each product.

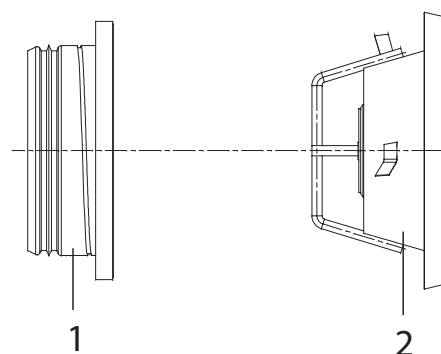

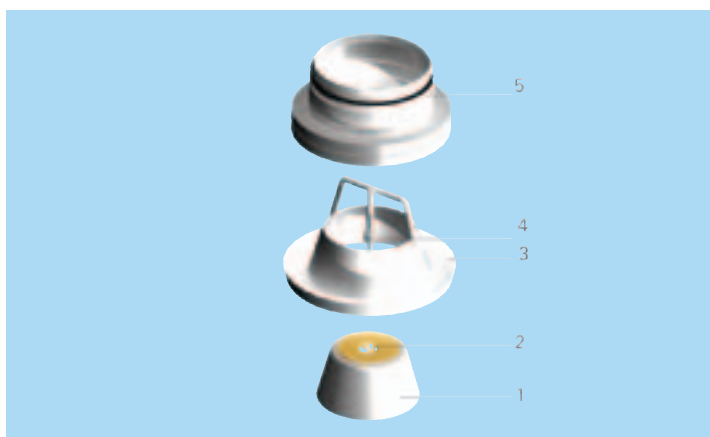

## Servicing

### CODE DESCRIPTION

1	Central cone
2	Fuse
3	Collar
4	Locking nut
5	Frame

Loosen the valve from the ductwork by turning anti-clockwise. Note the adjusted opening position of the central cone.

Wipe the parts with a damp cloth, instead of immersing in water. After cleaning, reattach the valve by pushing it into the installation frame and turning it until it is firmly attached.

Note: Do not use hot water or high temperatures during cleaning, as this could cause unnecessary release of the fuse.

## Adjustment

The valve is adjusted by rotating the central cone. Measure the opening (A) position (in mm) of the central cone. Set a probe inside the valve, and measure the differential pressure with a manometer. The air flow rate is calculated by using the formula below. After the adjustment, lock the central cone with the locking nut.

$$q_v = k * \sqrt{\Delta p_m}$$



FDV Ø 100		FDV Ø 125		FDV Ø 160		FDV Ø 200	
A	k	A	k	A	k	A	k
-15	0,43	-15	0,65	-12	1,16	3	1,78
-12	0,63	-12	0,92	-9	1,51	6	2,46
-9	0,83	-9	1,22	-6	1,9	9	3,24
-6	1,02	-6	1,53	-3	2,31	12	3,97
-3	1,22	-3	1,84	0	2,75	15	4,69
0	1,42	0	2,17	3	3,25	20	5,88
3	1,65	3	2,52	6	3,73	25	6,95
6	1,88	6	2,83	9	4,22		
9	2,11	9	3,14	12	4,67		
12	2,33	12	3,46	15	5,12		
		15	3,77	18	5,58		

## Suggested specifications

The technical properties of the type-approved fire valve shall conform to the EN 1366-2 and EN 135013 standards.

The valve shall be of fire resistance class ES120, EIS15 for lightweight concrete or masonry walls.

The valve shall be of fire resistance class ES120, EIS30 for installation on concrete slabs.

The fire valve shall be equipped with a thermal fuse and release spring and with fire-resistant sealing.

The integral installation frame shall be equipped with a sealing gasket and fire seal at its flange.

It shall be possible to install the damper from the room side.

The fire valve shall have an adjustable central cone and collar made of epoxy-painted steel, with white (RAL 9010) as the standard colour.

The opening position of the central cone shall be adjusted during balancing in order to achieve the required pressure loss and air flow rate.

After balancing, the central cone shall be locked into the selected adjustment position.

The internal quality control system of the fire damper manufacturer shall be based on the ISO 9001 system, and the manufacturer's operations shall be subject to external third-party quality control VTT.

## Product code

FDV-D

D = Connection size (mm)  
100, 125, 160, 200

Specifics and accessories

CO = Colour  
W White  
X Special colour

FU = Fuse release temperature (°C)  
50  
72 (recommended)  
100

Code example

FDV-100, CO=W, FU=72