

# Analysis of Capture and Containment Efficiency of a Ventilated Ceiling

Risto Kosonen and Panu Mustakallio

Halton Oy, Halton Singapore Rep. Office, 22 Leonie Hill Road #16-01,  
Singapore 239195

## Abstract

The efficiency of an exhaust system is especially important in a kitchen environment in which the exhaust is located at ceiling level. The capture efficiency of the total system must be guaranteed so that the spread of impurities throughout the kitchen is prevented. A capture efficiency model is derived and it is used to estimate the efficiency of a ventilated ceiling. This paper demonstrates that a simple equation that includes the average contaminant level in the occupied zone and the exhaust concentration could be a suitable platform for capture efficiency analysis in both measurements and simulations. With a ceiling height of 2.3 m, the capture and containment efficiency can be as high as 85 - 90 %; with a 2.6 m ceiling height it is 80 - 85 %. These values are quite reasonable compared with the capture efficiency of a default hood in the German code of practice (VDI, 1984).

**Key words:** capture efficiency, ventilated ceiling, kitchen ventilation, calculation techniques

## 1. Introduction

Concerns over the indoor environment have increased during recent years as a result of knowledge about the significance of thermal conditions and air quality on the health, comfort and productivity of workers. In a commercial kitchen, working conditions are especially demanding. There are four main factors affecting thermal comfort, these being: air temperature, radiation, air velocity and air humidity. At the same time, high emission rates of contaminants are released from the cooking process. Ventilation plays an important role in providing comfortable and productive working conditions and in securing contaminant removal.

The ventilated ceiling approach offers a flexible solution for kitchens where the heat loads are relatively low and aesthetics are a concern (DW/171, 1999). With the ventilated ceiling, it is possible to maintain good thermal conditions in the occupied zone with a reasonable air flow rate (Akimoto et al., 2002 and Horikawa et al., 2002). Structurally, the system consists of a stainless steel element that covers either the entire ceiling or only the active cooking area of a kitchen. It incorporates air inlets, exhaust air outlets (including grease filters), and light fittings.

The efficiency of the exhaust system is especially important, where the exhaust is located at ceiling

level. The capture efficiency of the total system must be guaranteed, so that the spread of impurities throughout the kitchen is prevented.

The efficiency of the exhaust system can be improved with a small capture jet installed at the ceiling surface (Kosonen and Mustakallio, 2003). This air jet is projected horizontally across the ceiling, which helps to direct heat and air impurities towards the exhaust. This capture jet represents only about 10 % of the total supply air flow rate.

There are a number of definitions for the capture efficiency of kitchen hoods and more general local exhaust in the literature e.g. Li et al. (1997) and Goodfellow and Tähti (2001). So far, there is not much work on the method and analysis relating to ventilated ceiling systems.

In this paper, the capture and containment efficiency of a ventilated ceiling is analysed using CFD-simulations. This was supported by laboratory measurements undertaken in another study (Lappeenranta, 1994). These laboratory measurements were conducted in a simple one-appliance-kitchen layout.

The same case-study kitchen is also simulated to obtain a more generic view of capture and containment efficiency in the kitchen environment. In the simulation, the effect of the exhaust air flow

rate and the height of the ceiling on the capture efficiency have been analysed.

The analysis of capture and containment efficiency is a logical continuation of a recent study by Kosonen and Mustakallio (2003) on the influence of a capture jet on the efficiency of a ventilated ceiling. In this previous study it was demonstrated that the supply air distribution strategy has a strong influence on pollution removal effectiveness and the thermal environment in kitchens.

## 2. Methodology

The capture and containment efficiency of the ventilated ceiling was evaluated using CFD-simulations and laboratory measurements in a case-study kitchen. The effect of the exhaust air flow rate and the height of the ceiling on the capture efficiency have been studied. The CFD simulations were conducted, in this study, using AirPak 2.0.6. The laboratory measurements were carried out, in a separate study, by the Lappeenranta Regional Institute of Occupational Health (Lappeenranta 1994). In this paper, the different definitions of capture efficiency are compared and the feasibility of the capture efficiency calculation to the ventilated ceiling system is discussed

### 2.1 The Case-Study Kitchen

The measurements were conducted in laboratory conditions with a mock-up kitchen at the Halton facilities. The kitchen floor area is 6.5 m x 9.5 m. The ventilated ceiling is 3.5 m x 4.3 m in area and is located either at 2.3 m or 2.6 m above floor level. Figure 1 shows the ventilated ceiling concept and the three measurement points underneath the structural ceiling.

The studied ventilated ceiling comprised exhaust, supply and capture jet units, with lights and ceiling elements between the exhaust and supply units. The capture jet air is supplied horizontally across the ceiling. This jet helps to direct heat and air impurities towards the exhaust.

The kitchen appliance (size 1200 mm x 800 mm x 870 mm (H)) consisted of a cooking range with a frying pan. The surface temperature of the appliance was about 200°C, with a total heat gain of 5.6 kW. The supply air temperature was 18°C and the room air temperature was 22°C.

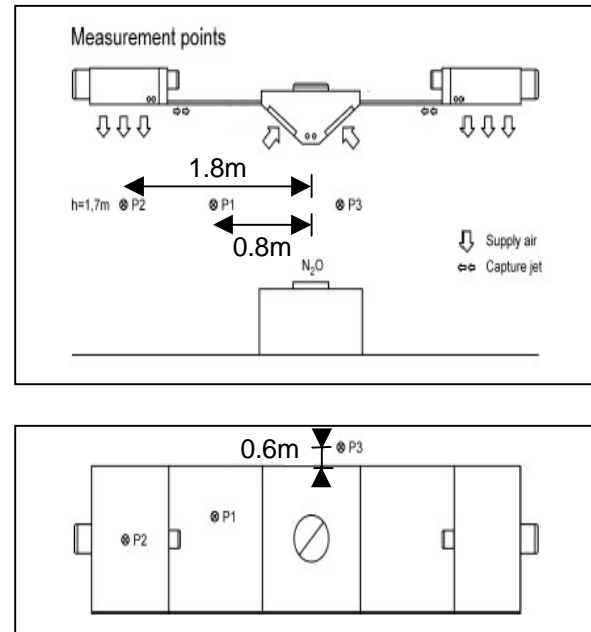

Figure 1. The layout of the mock-up kitchen showing measuring points.

The capture efficiency was studied in the case-study kitchen. Measurements and CFD- simulations were conducted at the two selected ceiling height (2.3 m and 2.6 m) and for various air flow rates. Table 1 presents the measured and simulated results for the different cases.

Table 1. The measured and simulated cases.

Ceiling Level (m)	Air flow Rates (l/s) Supply+ Capture Jet / Exhaust	Measured (M)/ Simulated (S)
2.3	245+ 65 / 400	(M)/ -
2.3	670+120 / 840	(M)/(S)
2.3	920+170 / 1090	(M)/ -
2.6	400+ 71 / 500	(M)/(S)
2.6	502+90 / 630	- /(S)
2.6	670+ 120 / 840	(M)/(S)
2.6	832+153 / 985	- /(S)
2.6	920+170 / 1090	(M)/(S)

### 2.2 Concepts of Capture Efficiency

#### Calculation and Measurement Methods

Kitchen ventilation standards and design guides do not mention any threshold values for capture

efficiency. The main purpose in design practice has been the adjustment of the air flow rate so that it is sufficient to extract the convective heat and contaminants from the occupied zone.

There are many methods available to determine the required exhaust air flow rate. For example face velocity (CP13, 2000), where air flow rate is determined by selected capture velocity and the area of the kitchen appliance under the hood. This method does not take into account the real heat gain of appliances. Hence, in many cases, the estimations always exceed the actual requirements or demands.

A more accurate method is based on monitoring the heat gain of the appliances (VDI, 1999). In this method, the convective heat output, the area of the appliance and the distance between hood and appliance are considered. There is also a supply configuration factor. For example, using a low velocity supply solution leads to a lower extract air flow rate than with traditional mixing ventilation.

A room energy balance approach is used in the earlier VDI (1984) standard. Based on the sensible load, the required air flow rate is calculated (Equation1). In the calculation a special factor, which takes into account the hood efficiency, is also determined. The hood efficiency is not unambiguously explained because the ratio of convection load, temperature gradient in the room space and the exact amount of the general exhaust are not determined.

$$q_{v,exh} = \frac{\varphi \cdot \sum_j (P_j \cdot \psi_j \cdot \eta_j)}{\rho \cdot c_p \cdot (t_r - t_{sup})} \quad (1)$$

where:

- $q_{v,exh}$  = supply airflow rate, m<sup>3</sup>/s
- $\varphi$  = simultaneous factor of kitchen equipment
- $P_j$  = connected load of the kitchen equipment j
- $\psi_j$  = sensible heat proportion of the connected load of the equipment j, W/W
- $\eta_j$  = room load factor of the hood for the equipment j
- $\rho$  = density of supply air
- $c_p$  = specific heat capacity of air
- $t_r$  = room air temperature
- $t_{sup}$  = supply air temperature

A default value of  $\eta_j$  is set to 0.8 if at least 80 % of the kitchen exhaust air is removed via hoods.

It should be noted that, with the hood, it is only possible to capture the convection part of the load. Radiation always comes into the room space. So, this means that the actual capture efficiency is only related to the convective part of the load.

Some codes (e.g. AS 1668.2, 2002) use either a prescriptive or an engineered procedure for hood design. This engineered procedure is a performance-based approach that allows the utilisation of suitable technology to reach the set targets. The solutions should be reviewed in the field or proven with appropriate calculations.

A complementary method to the calculation method is to use measurements to determine an adequate air flow rate in the test conditions. The most popular methods are UL-710 (Underwriters Laboratories, 1995) and F 1704-99 (ASTM, 1999). Both of these methods are based on visual observation. In the UL method, an inspector observes the capture and containment efficiency in the laboratory and, based on visual tests, the minimum required air flow rate is fixed. In the ASTM test, Schliering technology is utilised to determine the threshold of capture and containment of a hood and appliance combination under idle and cooking conditions. The ASTM test gives an accurate platform for the study of hood efficiency in different cooking processes.

None of these calculation methods or measurement technologies are specially tailored for the kitchen ceiling environment. In normal design practice, empirical knowledge of existing installations, together with heat load based calculations, have been used for air flow rate determination.

#### Definition of Capture Efficiency

It is common practice to characterise the contaminant removal performance of kitchen hoods in terms of capture efficiency, defined as a ratio between the flow rate of captured contaminant and the total emission rate of contaminants from the source. Although fairly simple in principle, it is not obvious how the capture efficiency of a kitchen extract system should be estimated.

Considering a local exhaust opening with the air flow rate of  $q_{v,exh}$  (m<sup>3</sup>/s) at a source of constant emission rate  $S_p$  (kg/s). For steady-state conditions, the capture rate of the exhaust is  $S_{exh}$  and the concentration at the exhaust point is  $c_{exh}$  (kg/m<sup>3</sup>).

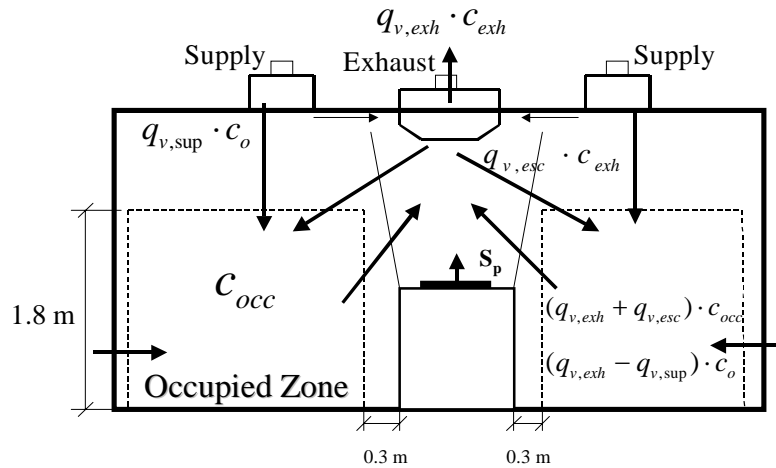

Figure 2. A two-zone model for a ventilated ceiling.

Then the total capture efficiency is:

$$\eta_{exh} = \frac{S_{exh}}{S_p} = \frac{q_{v,exh} \cdot c_{exh}}{S_p} \quad (2)$$

It is possible to derive the capture efficiency using the emission rate escaping ( $S_{esc}$ ) from the hood to give:

$$\eta_{exh} = \frac{S_{exh}}{S_p} = \frac{S_p - S_{esc}}{S_p} \quad (3)$$

There are some practical problems, as pointed out in Li and Delsante (1996), in using Equations 1 and 2 in a confined space where there is no general exhaust. If a kitchen space is airtight, the mass balance requires that the contaminant flow rate is equal to the contaminant generated at the source. In other words, the same mass flow is extracted as is released into the space. The capture efficiency calculated with Equation 1 gives 100 %. On the other hand, if there is high infiltration (or even an open space), the escaped contaminant does not cause any significant change in the concentration in the room space.

A simple two-zone model has been derived for capture efficiency in a confined space (Farsworth et al. 1989). Later, the model derivation was developed to include general exhaust by Li and Delsante (1996).

In this study, with the adaptation of Li's approach, a ventilated ceiling model in a confined space is introduced. In the model, the active height from the floor is set to 1.8 m and the distance from the wall

to the appliances is set to 0.3 m (Figure 2). It should be noted that the overhang of a typical hood is around 25 - 30 cm to cover the dilation angle (12°) of the rising plume (VDI, 1999).

In the selected assumptions, consideration is restricted only to the occupied zone. The boundaries that contain this zone enclose the volume that is under analysis. Ventilation to the occupied zone is from the ceiling supply only and this zone is assumed to be fully mixed.

Using a two-zone model, it is possible to derive mass conservation of the contaminant to the whole room and on the other hand to the occupied zone (Figure 2). The room balance is determined assuming that the room air is totally mixed:

$$S_p + (q_{v,exh} - q_{v,sup}) \cdot c_o + q_{v,sup} \cdot c_o = q_{v,exh} \cdot c_{exh} \quad (4)$$

where:

- $c_o$  = pollution concentration outdoors ( $\text{kg}/\text{m}^3$ );
- $q_{v,sup}$  = supply airflow rate ( $\text{m}^3/\text{s}$ ).

The mass balance of the occupied zone is given by:

$$(q_{v,exh} - q_{v,sup}) \cdot c_o + q_{v,sup} \cdot c_o + q_{v,esc} \cdot c_{exh} = (q_{v,esc} + q_{v,exh}) \cdot c_{occ} \quad (5)$$

where:

- $c_{occ}$  = pollution concentration in the occupied zone ( $\text{kg}/\text{m}^3$ );
- $q_{v,esc}$  = escaped air flow rate ( $\text{m}^3/\text{s}$ ).

After rearrangement, we have:

$$S_p = q_{v,exh} \cdot (c_{exh} - c_o) \quad (6)$$

$$q_{v,esc} = q_{v,exh} \cdot \frac{(c_{occ} - c_o)}{(c_{exh} - c_{occ})} \quad (7)$$

Defining the capture efficiency as the ratio of captured contaminants to the total contaminant source (including contaminant source and contaminant in the induction air), we have:

$$\eta_{exh} = \frac{q_{v,exh} \cdot c_{exh}}{S_p + (q_{v,exh} + q_{v,esc}) \cdot c_{occ}} \quad (8)$$

Substituting Equations (5) and (6) into Equation (8) gives:

$$\eta_{exh} = \frac{q_{v,exh}}{q_{v,exh} + q_{v,esc}} \quad (9)$$

Substituting Equation (7) into Equation (9) gives:

$$\eta_{exh} = \frac{1}{1 + \frac{c_{occ} - c_o}{c_{exh} - c_{occ}}} \quad (10)$$

After rearrangement, we have:

$$\eta_{exh} = 1 - \frac{c_{occ} - c_o}{c_{exh} - c_o} \quad (11)$$

By assuming that outdoor concentration ( $c_o$ ) is zero, the capture efficiency is finally given by:

$$\eta_{exh} = 1 - \frac{c_{occ}}{c_{exh}} \quad (12)$$

The concept of direct capture efficiency is proposed by Jansson (1990) and Madsen et al. (1994). This approach is also used in the industrial design guidebook (Goodfellow and Tähti, 2001). In this approach, the captured contaminants are divided into two parts:

- 1) the contaminants directly captured by the local exhaust;
- 2) the contaminants which, at first, escape and after that are captured by the local exhaust.

However, there are measurement and numerical calculation problems in distinguishing the rate of directly captured contaminants from the total captured contaminants, and only an estimation of these factors is possible.

In their industrial design guide (Goodfellow and Tähti, 2001), this approach is used to determine the capture efficiency of the local exhaust. The mass balance of the exhaust is given by:

$$S_p + (q_{v,exh} + q_{v,esc}) \cdot c_{occ} = q_{v,exh} \cdot c_{exh} + q_{v,esc} \cdot c_{exh} \quad (13)$$

Equation (13) can be expressed as:

$$S_p = q_{v,exh} \cdot (c_{exh} - c_{occ}) + q_{v,esc} \cdot (c_{exh} - c_{occ}) \quad (14)$$

The right side of Equation (14) can be looked at as two parts:  $q_{v,exh}(c_{exh}-c_{occ})$  is the directly captured part of the emission and  $q_{v,esc}(c_{exh}-c_{occ})$  is the part of the emissions escaping into the room.

Capture efficiency is then defined as:

$$\eta_{exh} = \frac{q_{v,exh} \cdot (c_{exh} - c_{occ})}{S_p} \quad (15)$$

The emissions escaping into the room is given by:

$$(1 - \eta_{exh}) \cdot S_p = q_{v,esc} \cdot (c_{exh} - c_{occ}) \quad (16)$$

It should be noted that if  $c_{exh} = S_p/q_{v,exh}$ , (Equation 6) is substituted in to Equation (15), we can get exactly the same equation as Equation (12). This shows that the released contaminants are always extracted. In other words, to focus only on the direct capture efficiency is not applicable in a ventilated ceiling environment. However, the direct and indirect components could be computed using the equations presented.

Equation (12) gives a practical platform for analysing the capture efficiency of a ventilated ceiling based on either simulations or measurements. Also, by measuring the concentration for a grid of points around the occupied zone, a more general view of the contaminant distribution may be obtained. This average value of the concentration in the occupied zone, together with the determination of the extract concentration, is then used to determine the capture efficiency.

### 3. Results

#### 3.1 Contaminant Simulations

Average contaminant concentrations are calculated for a 6.5 m x 9.5 m x 1.8 m (H) volume. The occupied zone is divided into four different control

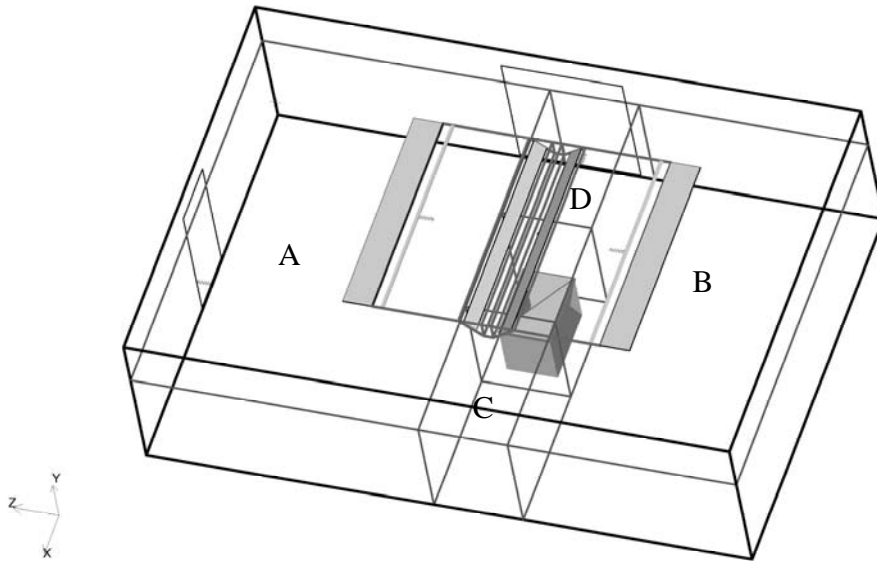

Figure 3. The calculated four control zones in the occupied zone.

zones in which average contaminant levels are computed. In the calculation, the volume over the range and, additionally, 0.3 m from each side of the appliance is not taken into account. Figure 3 shows the calculated control zones. It should be noted that the volumes A and B are not the same because the range is not located in the middle of the space. The

room was divided into a hexahedral grid system with 324,818 cells and a refining mesh, locally, in critical regions. Based on grid refinement studies, this mesh was deemed to be sufficiently fine to capture all significant flow features and the concentration distribution.

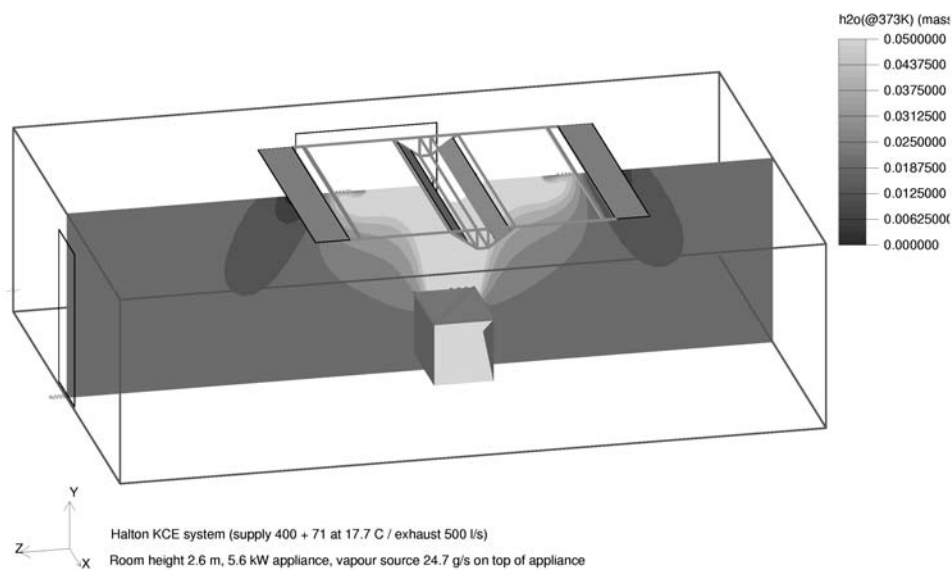

Figure 4. Contaminant level with 500l/s air flow rate. The ceiling height is 2.6m.

All CFD computations were performed using AirPak 2.0.6. The equations for conservation of mass, momentum and energy were solved using the finite-volume method. The standard  $k-\epsilon$  model was employed for a turbulence closure and the ideal gas

law was applied in modelling buoyancy. All simulations were performed as steady-state. First-order discretisation of the governing equations was used because, in this application, it gave much better convergence than the second-order scheme.

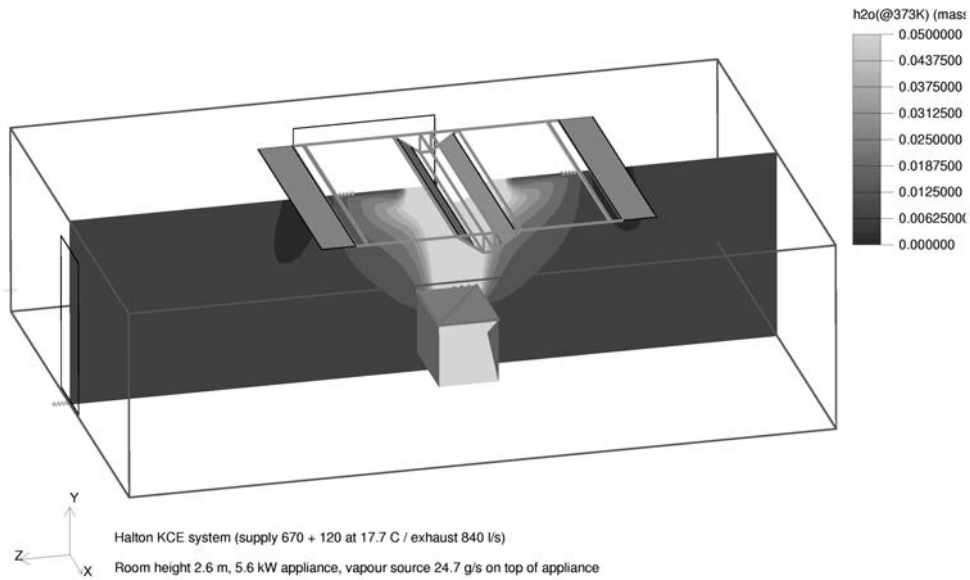

Figure 5. Contaminant level with 840 l/s air flow rate. The ceiling height is 2.6 m.

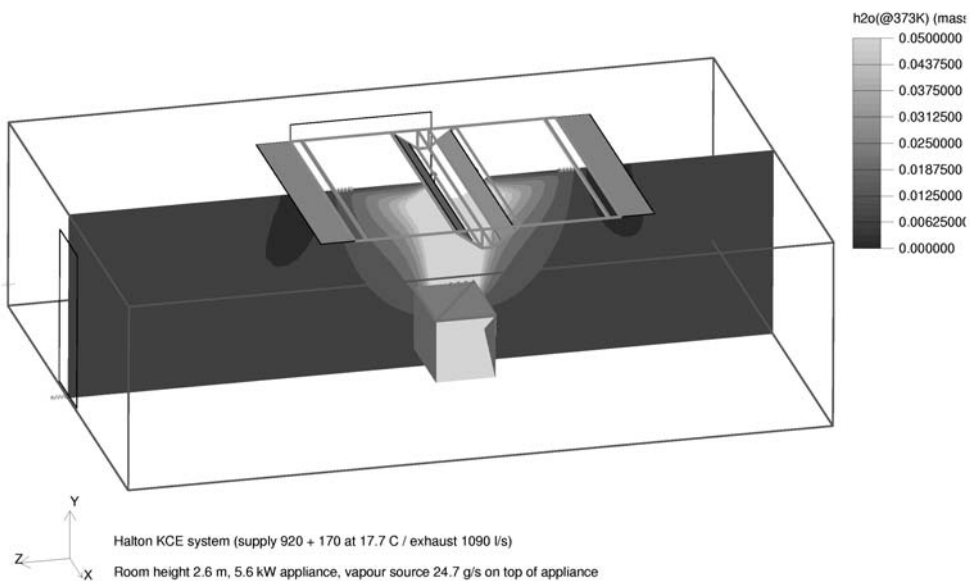

Figure 6. Contaminant level with 1090 l/s air flow rate. The ceiling height is 2.6 m.

Commonly used boundary conditions, i.e. an inlet boundary and a pressure boundary, were applied at the air inlet and outlet of the ventilation system. Openings at the bottom of doors were used for infiltration of air into the kitchen. The kitchen appliance was modelled for heat gain. The pollution source in the simulations was 24.7 g/s of water vapour. This was modelled using a diffusion-convection equation to predict the local mass fraction of pollution. Figures 4, 5 and 6 show the contaminant levels for different air flow rates (500 l/s, 890 l/s and 1090 l/s).

Figures 4 and 5 show clearly that, by increasing the air flow rate from 500 l/s to 890 l/s, it is possible to decrease the contaminant concentration level in the occupied zone. However, the higher air flow rate of 1090 l/s (Figure 6) does not enhance the air quality in the working area. This shows that there is a certain rate of exhaust air flow which is economical and high enough to remove the contaminants from the occupied zone. Figures 4 to 6 also show that the contaminants are quite well-mixed in the occupied zone. Only the areas close to the range and under the supply unit are different from the average contaminant level.

Table 2 shows the calculated concentration levels using different air flow rates for a 2.6 m ceiling height, plus one reference case for a ceiling height of 2.3 m. The concentration level in the extract is calculated, based on the continuity equation. For the reference ceiling height of 2.3 m, it is possible to reach the lowest absolute concentration level in the occupied zone. Even if the air flow rate is increased, it is not possible to reach the same concentration level for the 2.6 m ceiling height.

In all cases the pollutant concentration is lower in control zones A and B, where the supply air flow rate is distributed. Depending on the case, the concentration in the A and B zones could be 9.6 – 21.7 % lower than in the control zones C and D where the fresh air is not directly released. Also, it should be noted that the volume weighted concentration of the whole kitchen is quite close to the average concentration of the control volumes A and B because the weighting factor of volumes C and D is relative small. In addition, it should be noted that the volumes A and B are the areas where chefs are working for most of the time.

Table 2. The average concentrations in control zones and extract point.

DESIGN CONCEPT	CONCENTRATIONS AND VOLUME WEIGHTED CONCENTRATIONS (g/g x 10 <sup>-2</sup> )							
	A	B	C	D	AVG (A-B)	AVG (C-D)	AVG (A-D)	EXH
Air flow Rates (l/s) Supply+ Capture Jet / Exhaust								
670+120 / 840 (2.3 m ceiling height)	0.3234	0.3299	0.4355	0.3980	0.3263	0.4167	0.3363	2.4504
400+ 71 / 500	1.0863	1.0967	1.2196	1.1927	1.0909	1.2062	1.1037	4.1167
502+90 / 630	0.7637	0.7861	0.8149	0.7646	0.7736	0.7897	0.7754	3.2672
670+ 120 / 840	0.4526	0.4613	0.5533	0.5157	0.4565	0.5345	0.4651	2.4504
832+153 / 985	0.5112	0.5180	0.6477	0.6354	0.5142	0.6415	0.5284	2.0897
920+170 / 1090	0.4713	0.4768	0.6083	0.5980	0.4737	0.6031	0.4881	1.8884

### 3.2 Calculated and Measured Capture Efficiency

In the same mock-up kitchen, measurements reported by Lappeenranta (1994) were compared with CFD-simulations. In the measurements, contaminant distribution was examined by releasing nitrous oxide, N<sub>2</sub>O, tracer gas on the cooking range at a constant flow rate of 210 l/h. The concentration of the tracer gas was measured at three locations in the occupied zone (See Figure 1). One sampling point was located in the middle between the supply and exhaust units (P1) and the other point (P2) was installed underneath the supply unit. The third point (P3) was 0.6 m away from the ventilated ceiling. All measurement points were at the 1.7 m level.

It should be noted that, at the sampling location (P1) next to the cooking range, the concentration of the tracer gas fluctuated due to draughts caused by the openings at the base of the door. The values used are the average values calculated without these concentration peaks. Using Equation 12 the capture efficiency was analysed for both simulated and measured cases. In the simulation, the average value of the volume A-D is used in the analysis.

The measured and calculated capture efficiencies for different air flow rates and for two ceiling heights (2.3 and 2.6 m) are presented in Table 3.

Both the measurement and simulated data give lower contaminant levels when the ceiling is at the 2.3 m level. The measured and simulated values of the capture efficiencies compare well for the best capture efficiency range. Outside the optimum range, the difference between the measured and calculated values increases. This could be due to the limited number of measurement points.

The measured and simulated capture efficiencies were 80.8 % and 81.0 % respectively for the 2.6 m ceiling height. However, higher measured and simulated capture efficiencies of 91.3 % and 86.3 % were obtained for the ceiling height of 2.3 m.

It should be noted that increasing the air flow rate will reduce the absolute values of the contaminants, even though the capture efficiency will decrease. The main target should be to maintain the contaminant level at an acceptable level and use the capture efficiency as an indicator of the system efficiency.

A comparison of the measured and simulated results was carried out with and without the capture jet feature (Kosonen and Mustakallio 2003) and indicated reasonable correlation. This study was conducted in the same mock-up kitchen environment.

Table 3. The measured and calculated capture efficiencies for different air flow rates and two ceiling heights.

CASES		MEASUREMENT						CFD
Ceiling Height (m)	Exhaust Air Flow (l/s)	P1 (ppm)	P2 (ppm)	P3 (ppm)	Average (ppm)	Exhaust (ppm)	Capture Efficiency (%)	Capture Efficiency (%)
2.6	500	74	119	74	89.0	156	42.9	73.2
2.6	630						(n.a.)	76.3
2.6	840	23	16	11	16.7	87	80.8	81.0
2.6	985						(n.a.)	74.7
2.6	1090	24	41	11	25.3	70	63.8	76.5
2.3	400	53	89	42	61.3	160	61.7	(n.a.)
2.3	840	8	10	4	7.3	84	91.3	86.3
2.3	1090	7	13	4	8.0	64	87.5	(n.a.)

(n.a.)= Not Available.

Based on the simulated and measured results, it is observed that a reasonable capture efficiency performance can be achieved using a ventilated ceiling system. At a ceiling height of 2.3 m, the capture and containment efficiency can be as high as 85-90 % and for a 2.6 m ceiling height 80 – 85 %, respectively.

#### 4. Discussion

In the engineered type of solution, such as the ventilated ceiling, it is not appropriate to separate which part of the contaminant is captured directly. The main idea of the ventilation system is to extract pollution from cooking in order to keep the pollution level in the occupied zone at an acceptable level. It does not matter whether the pollutants are removed directly or indirectly as long as the space condition is within the threshold value.

In the capture and containment efficiency calculation, it is not reasonable to use the whole kitchen volume. It is only the occupied zone that is important. In addition, the dilation angle of the plume should be taken into account and the adjacent area 0.3 m from the appliances should be neglected in the calculation. Because the overhang of a hood is typically about 0.2-0.3 m, this approach gives a natural way to compare the capture efficiencies of ventilated ceilings and hoods.

The occupied zone of the ventilated ceiling kitchen seems to be reasonably mixed. This means that the 2-zonal model is applicable. In the control volume under the supply unit, the contaminant concentration was about 10 – 20 % lower than in the control volumes in line with the appliance. This indicates that the capture efficiency can be measured quite accurately using a grid of the contaminant measurement in the occupied zone combined with the exhaust concentration. Using CFD-simulation, it is possible to compute the average contaminant concentration. Thus, determination of the capture and containment efficiency is easy to execute.

At the moment, there are no standardised target values for capture and containment efficiency, even for kitchen hoods, in any code of practice. To get some kind of perspective, we can use the 1984 version of VDI (VDI, 1984) as a basis as described in Section 2.2. In that code of practice, a default value of  $\eta_j$  is set to 0.8 if at least 80 % of the kitchen exhaust air is removed via hoods. If it is assumed that the convection ratio is constant 50%

and the general exhaust is 20% of the total exhaust air flow rate, the hood efficiency will be 67%.

This is based on the assumption that 50% of the total heat load is radiative (and therefore cannot be captured) while a further 20% of the total load is general emission into the room. Therefore a maximum 30% of the total heat load is available for capture. If an amount equivalent to 10 % of the total heat load is spilled from the hood, the total captured convection load will be 20% of the total load. Therefore, the hood efficiency, expressed as a fraction of the convective heat load is  $20/30 = 67\%$ .

CFD-simulations and previous measurements have demonstrated that the capture efficiency could be as high as 80-85 % (ceiling height 2.6 m) and 85-90 % (ceiling height 2.3 m). These values are quite reasonable e.g. if the values are compared with previous capture efficiency of the 1984 VDI standard default value.

It is possible to calculate the ratio of the escaped and the exhaust air flow rates using Equation (9) and the capture efficiency values of the CFD simulations. At the maximum capture efficiency values of 86.3 % and 81.0 %, the escaped air flow rate ratios are 0.16 and 0.23 respectively. In the other simulated cases, the ratio is between 0.31 – 0.37. This indicates that, in all cases, the escaped air flow rate is significant. In addition, it means that the indirect part of the captured contaminant is quite significant.

It should be noted that the above results are only estimates based on a simplification, represented by a 2-zone model, of complex air movements in the space. Unfortunately, present numerical methods are unable to distinguish the rate of direct and indirect captured contaminants and there are also limitations in current measurement technologies.

High capture efficiency values were obtained for this simple one-appliance case. In the future, the whole kitchen should be analysed and a more accurate air flow rate design method should be developed to evaluate capture performance.

#### 5. Conclusions

A capture efficiency model has been derived and used to estimate the capture efficiency of a ventilated ceiling in a commercial kitchen. A simple equation, which includes the average contaminant concentration in the occupied zone and the exhaust

concentration, could be a suitable platform for both measurements and simulations. For a ceiling height of 2.3 m, the capture and containment efficiency can be as high as 85 - 90 % and with a 2.6 m ceiling height it can be 80 – 85 %. These values are quite reasonable compared with the capture efficiency of a default hood of the type considered in the 1984 German VDI standard.

## Acknowledgements

The study is supported by Technology Agency of Finland (TEKES). The authors wish to thank to Drs David Cheong and Freddie Tan for their comments.

## References

- Akimoto T, Horikawa S, Otaka K, Hayashi H and Lee S: (2002) "Research on ventilation ceiling system for commercial kitchen. Part 2: Field measurement of indoor thermal environment and ventilation performance", *Roomvent 2002*, 8-11 September 2002 Copenhagen Denmark,
- AS 1668.2-2002: (2002), The building code of Australia "Part F4- Light and ventilation" Australian Standard.
- ASTM: (1999) Standard F1704-99: "Standard test methods for performance of commercial kitchen ventilation systems." United States.
- CP 13: (2000) "Singaporean code of practice for mechanical ventilation and air-conditioning in buildings" Singapore February 2000.
- DW/171: (1999) "Standard for kitchen ventilation systems." Heating and Ventilation Contractors Association, London.
- Farsworth C, Waters RM, Kelso M and Fritzsche D: (1989) "Development of a fully vented gas range" Appendix A, *ASHRAE Transactions*, **95**, (1), pp759-768.
- Goodfellow H and Tähti E: (2001) "Industrial ventilation design guidebook", Chapter 10: Local ventilation, Academic Press, 1520 pages.
- Horikawa S, Otaka K, Hayashi H, Lee S and Akimoto T: (2002) "Research on ventilation ceiling system for commercial kitchen. Part 1: Computational fluid dynamic analysis and field measurement", *Roomvent 2002*, 8-11 September 2002 Copenhagen Denmark.
- Jansson A: (1990) "Local exhaust ventilation and aerosol behaviour in industrial workspace air", Ph.D. thesis, School of Civil Engineering, Royal Institute of Technology, Stockholm, Sweden.
- Kosonen R and Mustakallio P: (2003) "The influence of a capture jet on the efficiency of a ventilated ceiling", *International Journal of Ventilation*, **1**, (3), pp 189-200.
- Lappeenranta: (1994): "Ventilation performance in a pilot kitchen with the integrated ventilating ceiling KCE." Lappeenranta Regional Institute of Occupational Health Report 94014 F.
- Li Y and Delsante A: (1996) "Derivation of capture efficiency of kitchen range hoods in a confined space", *Building and Environment*, **31**, (5), pp 461-468.
- Li Y, Delsante A and Symons J: (1997) "Residential kitchen range hoods- buoyancy capture principle and capture efficiency revisited", *Indoor Air*, **7**, pp151-157.
- Madsen U, Breum NO and Nielsen PV: (1994) "Local exhaust ventilation- a numerical and experimental study of capture", *Building and Environment*, **29**, (3), pp 319-323.
- Underwriters Laboratories: (1995), Standard UL-710 "Exhaust hoods for commercial cooking equipment" 5<sup>th</sup> edition.
- VDI (1984) "Standard 2052: Ventilation equipment for kitchens." Verein Deutcher Ingenieure.
- VDI (1999) "Standard 2052: Ventilation equipment for kitchens." Verein Deutcher Ingenieure.

