

Displacement Ventilation – Application for Hot and Humid Climate

ANDREY LIVCHAK, *Research Director, Halton Company, USA*

DANIEL NALL, *Principal, Director of Advanced Technology, Flack+Kurtz Inc, USA*

ABSTRACT

The indoor climate and air quality has a significant effect on our health, productivity and overall enjoyment of life. It is common knowledge that Thermal Displacement Ventilation systems can significantly improve Indoor Air Quality and reduce the energy consumption of air conditioning systems. Though these systems have been used successfully in Northern Europe for three decades, Displacement Ventilation exposure to warmer climates still remains limited. The reason: different climate conditions call for different ventilation system designs. For example most of Displacement Ventilation systems in Northern Europe are 100% outside air systems and design methods suggest minimum supply air temperature at 18...19°C disregarding the room moisture balance.

1. INTRODUCTION

Business Week magazine puts on the front page the shocking title “Is Your Office Killing You?” referring in the article to the Environmental Protection Agency: “The EPA says that indoor air is one of the top five environmental health risks of our time”. An increased concern over the Indoor air quality and the higher energy costs challenges the HVAC designers in the USA to look for more effective ways to ventilate the space. No wonder that Displacement Ventilation Systems that are being successfully used for many years primarily in Northern Europe attract more and more attention in the USA as well. There are quite a few sites in the USA including schools (W. Turner 1999), office buildings, fitness centers and industrial facilities where Displacement Ventilation is used providing better indoor air quality and saving energy for air conditioning systems. Existing European design practices including recent publications on Displacement Ventilation System design do not address essential issues for the US local design practices and climate conditions including:

- Design for air conditioning systems with return air
- Account for the moisture of outside air
- Calculate room air relative humidity
- Possibility to account for different supply temperatures

2. DISPLACEMENT VENTILATION SYSTEM DESIGN

Displacement Ventilation Design consists of the following steps:

1. Select supply air temperature to comply with the space comfort requirements

2. Calculate supply airflow based on the space cooling load, design space air temperature and ventilation system configuration.
3. Design air handling unit
4. Select displacement diffusers and position them in the space.

The air temperature supplied from displacement diffusers is selected considering how close an occupant will be to the diffuser and the type of activity the occupant is doing. In case of a school, office, auditorium or restaurant where person will be seated close to a diffuser, supply air temperature is typically 19 ... 20°C. In industrial spaces where a worker can be far from the diffuser or in specific applications such as gymnasiums the supply temperature can be the same as typically used in mixing ventilation systems 13 ... 14°C (A. Livchak, R. Bagwell, R. Catan, 1999).

Depending on the space requirements two types of design methods are being used. Temperature based design method is used when heat is considered to be the main source of contaminants. The more complicated, however more accurate, shift zone method is used when other contaminants accompanying thermal plumes from the heat sources should be considered.

2.1 Temperature based design

The supply airflow m_s required to maintain the space design temperature t_r and the air temperature in the upper part of the space t_{ex} are calculated from the room energy balance. The space is divided into two zones: the lower occupied zone where people are and the upper unoccupied zone – everything above the occupied zone. Essentially the heat from cooling loads in the space Q_{l-t} is split into two parts: one that is assigned to the occupied zone Q_{l-oz} and the other is being transmitted to the upper, unoccupied zone Q_{l-uz} . To be able to split Q_{l-t} into Q_{l-oz} and Q_{l-uz} one should have the detailed information on the cooling loads including its type, dimensions, location in the space (including height above the floor) and what portion of the sensible heat is emitted to the space by convection.

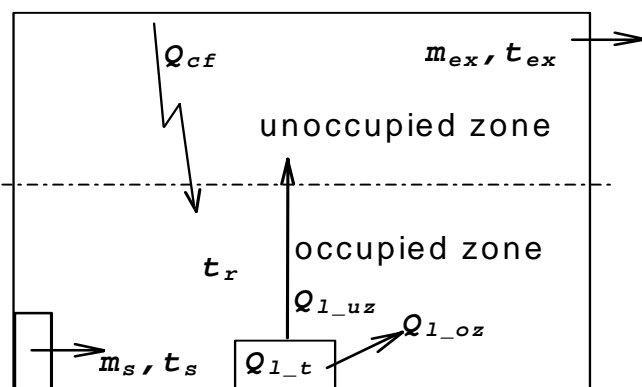

Figure 1 Room Energy Balance

The higher air temperature in the upper part of the room will warm up the ceiling that will radiate heat partially back to the occupied zone Q_{cf} . Q_{cf} depends on the ceiling height and the floor free area. The supply airflow m_s can be calculated from the following system of equations.

$$Q_{oz} = Q_{l-oz} + Q_{cf} \quad (1)$$

$$Q_{oz} = m_s \cdot c_p (t_r - t_s) \quad (2)$$

$$Q_t = m_{ex} \cdot c_p (t_{ex} - t_s) \quad (3)$$

$$Q_{cf} = \sigma \cdot \varphi \cdot \varepsilon \cdot A_f \left(\frac{T_c}{100}^4 - \frac{T_f}{100}^4 \right) \quad (4)$$

$$m_s = m_{ex} \quad (5)$$

Typical air conditioning systems in the USA utilize return air. If the return grill is installed near the ceiling, equations 1...5 do not change, however if return air is taken from the lower

part of the space, the air temperature would be lower, and equations 3 and 5 will change into equations 3.1 and 5.1.

$$Q_t = m_{ex} \cdot c_p (t_{ex} - t_s) + m_{ret} \cdot c_p (t_{ret} - t_s) \quad (3.1)$$

$$m_s = m_{ex} + m_{ret} \quad (5.1)$$

Returning air from the lower part still requires exhaust air from the upper part of the space in the amount equal to the minimum amount of outside air.

2.2 Shift Zone design method.

When designing a space where heat is not the only contaminant source we should utilize the ability of the displacement system to stratify the contaminants¹ above the occupied zone. The shift zone is the plane in the space where the total amount of air carried in the convective plumes above the heat sources is equal to the supply airflow distributed through the displacement diffusers located in the occupied zone.

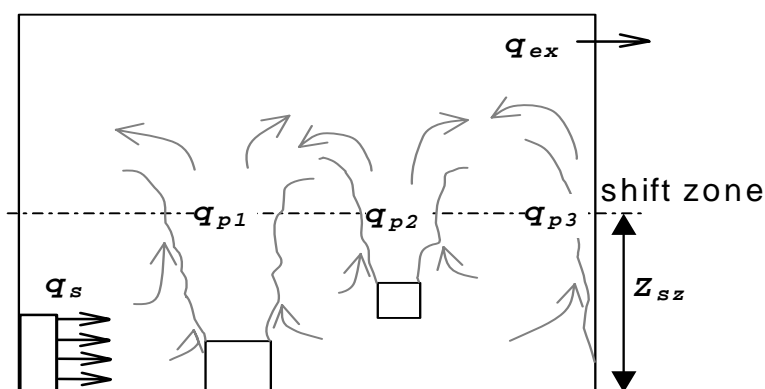

Figure 2 Shift Zone Design

Generally in a space with a displacement ventilation system concentration of contaminants above the shift zone is higher than below it. This is true especially when

contaminants are lighter than air or neutral but are being carried by convective plumes of warm air. Heiselberg and Sandberg (1990) studied concentration of tracer gas ejected in the boundary layer at the bottom of a heated cylinder in the room 2.5 m high. Observations showed that depending on the supply airflow tracer gas concentration in the room at 2.25 m was from 5 to 10 times higher than at 1 m high.

When designing according to the Shift Zone design method the same set of equations 1...5 from the Temperature Based design is used, however additional condition for the total volumetric supply airflow q_s is used to maintain the shift zone height Z_{sz} .

$$q_s \geq \sum q_{p_i} @ Z_{sz} \quad (6)$$

Both Temperature and especially Shift Zone design methods, where calculation of the airflow in the plumes above the heat sources is required, are too complex and time consuming for manual calculations. Specially designed Displacement Ventilation software has been used to simplify the design process. We also encourage the HVAC designers to use Computational Fluid Dynamic software packages to design Displacement Ventilation systems, especially when calculating large and complex spaces.

3. DISPLACEMENT VENTILATION AND ROOM RELATIVE HUMIDITY

Very little measurement information is available on this subject. We do know that temperature does stratify in the space when a Thermal Displacement system is used. If we

¹ Contaminants that are lighter or have the same density as air but follow the plumes from the heat sources.

assume that room air relative humidity remains constant throughout the space - common assumption in mixing systems - then the humidity ratio of air in the upper part of the room will be higher due to the higher than in the occupied zone air temperature. This assumption will allow us to conclude that Displacement Ventilation stratifies moisture as well. Field studies regarding humidity were conducted in 1988 in a food-processing facility located in Finland. The factory is equipped with a variable air volume displacement ventilation system. Measurement data is presented in Figures 3, 4 for full load (total convective heat flux from equipment 90 W/m^2 ; supply airflow $10 \text{ l/(s}\cdot\text{m}^2)$) and half load (total convective heat flux from equipment 45 W/m^2 ; supply airflow $5 \text{ l/(s}\cdot\text{m}^2)$). Figure 3 illustrates the temperature gradient in the space, Figure 4 shows the moisture gradient in the factory using different units: humidity ratio and relative humidity.

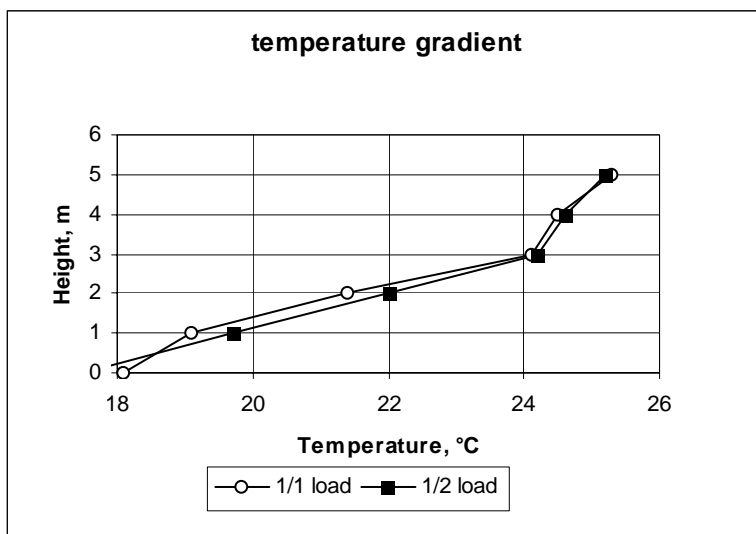
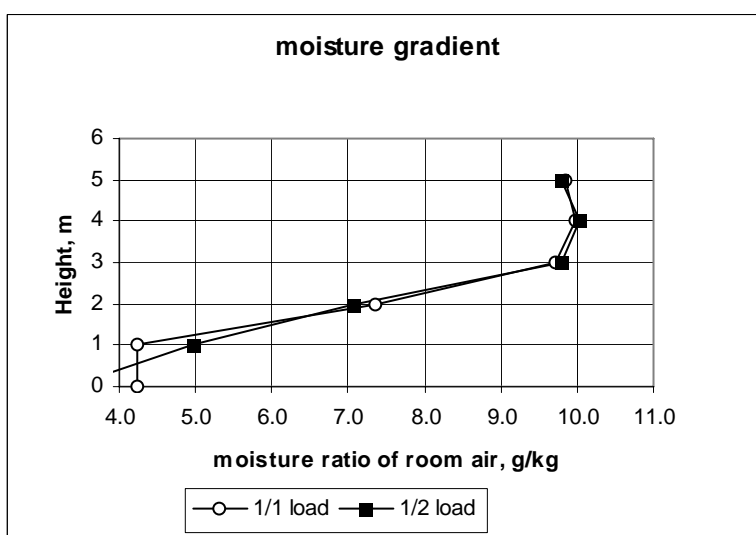

Figure 3. Displacement Ventilation, temperature gradient in the space



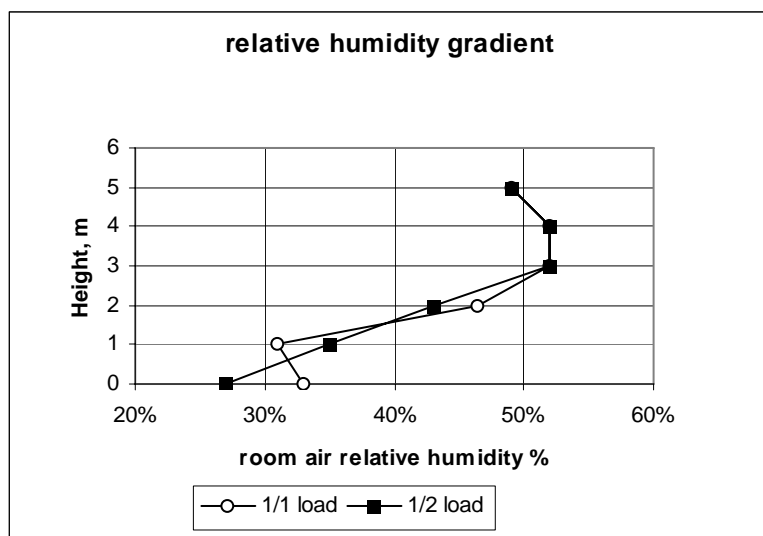

Figure 4 Displacement Ventilation, moisture gradient in the space.

The charts on Figure 4 show that moisture does stratify in the factory with not only humidity ratio but also the air relative humidity being higher above 3 m from the floor. In this case Displacement Ventilation is more effective in moisture removal compared to a mixing ventilation system. Food preparation is usually associated with the steam generation. The steam follows convective plumes from the equipment thus being transported to the upper part of the space. This explains the fact that moisture stratifies in this case having approximately 2 times higher humidity ratio in the upper part of the factory.

5. DISPLACEMENT VENTILATION AND SUPPLY AIR MOISTURE

Since the supply air temperature in Displacement Ventilation systems is typically 18...20°C special attention should be paid to the humidity ratio of the outside air that passes through the cooling coil.

One of the efficient ways to control both moisture and supply air temperature would be to recirculate room air after the cooling coil. It can be done by inducing the return air before and after the cooling coil at the central air-handling unit AHU.

Fig 5 and 6 illustrate the AHU schematic for Displacement Ventilation system with and without humidity control accordingly. The Displacement Ventilation system selection software has been used to calculate the system. The space was designed for 23°C and maximum relative humidity 60%.

Displacement Ventilation

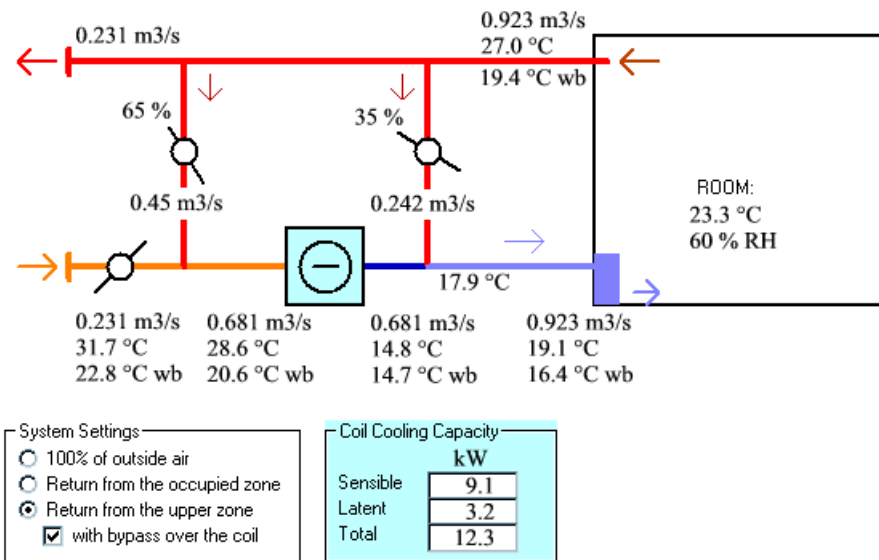

Figure 5. Printout of the Displacement Ventilation program for the system with humidity control of supply air.

Displacement Ventilation

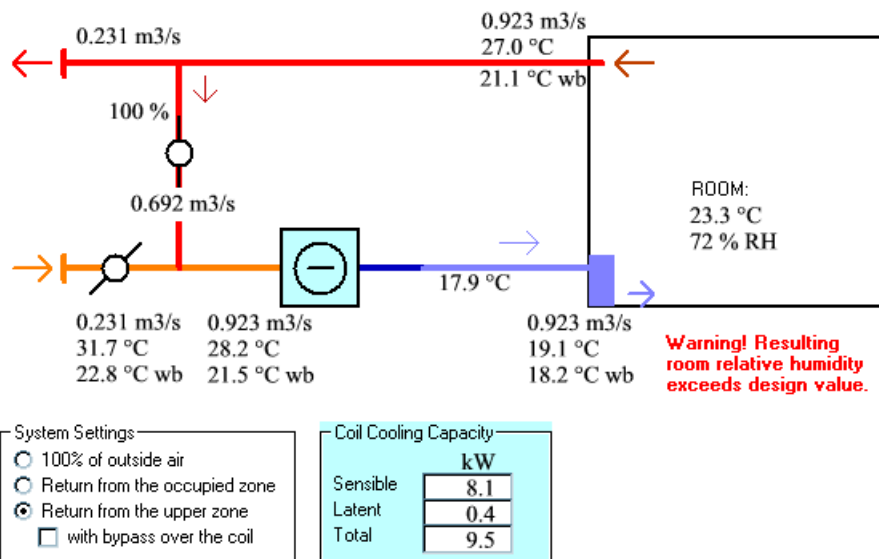

Figure 6 Printout of the Displacement Ventilation program for the system without humidity control.

Returning part of the air after the cooling coil (Figure 5) allows the design level of the relative humidity in the space to be reached by reducing the off-coil temperature. The dry-bulb supply air temperature is maintained at the same level in both cases (Figures 5, 6).

Another method of controlling humidity for densely populated spaces in humid climates is to utilize the required ventilation air alone to provide the dehumidification. The moderately active adult human being releases approximately $2.8 \cdot 10^{-5}$ kg/s of moisture vapor into the air. Many building and public health codes stipulate outside ventilation air quantities of at least $0.01 \text{ m}^3/\text{s}$ per person. This volume represents a minimum mass flow per person of outside air

of approximately 0.013 kg/s. If the outside air is the only source of dehumidification and the occupants the only source of latent gain, then the space will exhibit a moisture ratio rise of approximately 2.1 g/kg with the minimal required ventilation. Based upon Figure 4, approximately 50% of the moisture gain may be considered to be in the occupied zone. Creation of a space condition of 24°C, 50% Relative Humidity, assuming a moisture ratio rise of 1.05 g/kg in the “Occupied Zone” would require cooling the outside air to a dew point temperature of 9.2°C. Mixing with recirculated room air at 27°C and with a fan temperature rise of 1.1°C, to obtain a supply temperature of 19°C would result in a recirculated air fraction of about 48%.

For some system configurations this technique can be very beneficial, resulting in central dehumidification with no distributed condensate pans or drainage. In fact, it can be used with local non-condensing cooling coils to utilize larger fractions of recirculated air to handle more concentrated sensible loads. Interior relative humidity sensors can modulate the amount of dehumidified ventilation air to maintain required relative humidity set points. When utilized with a demand controlled ventilation system, which varies ventilation air to provide constant ventilation per person to a varying population, this technique can be very energy efficient, particularly if human transpiration represents the preponderance of latent load in the space. The system utilizes carbon dioxide sensors to maintain a constant carbon dioxide concentration differential between outside air and space air. Because carbon dioxide generation per adult human being can be considered constant for a given metabolic level, maintaining a constant differential insures maintaining a constant flow per person. This version of a dehumidifying displacement ventilation system becomes very similar to induction based systems such as active chilled beams, except that the stratification of moisture ratio in the space with the displacement ventilation regime, similar to the temperature stratification, allows higher dew point temperatures in the primary air for maintenance of required humidity levels. The result is greater energy efficiency in the refrigeration system due to reduced temperature differentials across the refrigerant loop.

6. COOLING CAPACITY AND ANNUAL ENERGY CONSUMPTION

To compare the energy consumption for both mixing and displacement systems we selected the computer room, an interior space without solar and skin load. Both mixing and displacement systems are designed with return air. Minimum amount of outside air is 0.142 m³/s. New York was selected as weather city. The bin method calculating energy over several intervals of temperature was used to determine annual energy consumption by the chiller. It is assumed that the chiller is used when outside air temperature is above supply air temperature. When outside air enthalpy is lower than enthalpy of the return air, the air handling unit switches to 100 % outside air. Chiller coefficient of performance is assumed 3 for both mixing and displacement system. The air conditioning system (chiller) is operating 9 hours per day, 5 days per week. The rest of the input data used for calculations is presented in Table 1.

Table 1. Input data

<i>Space Data and Design Conditions, New York, NY</i>	
Height, m	3
Width, m	12
Length, m	18

Room design air temperature, °C	23.3
Room air maximum relative humidity, %	60
Design outside air temperature	
dry-bulb, °C	31.1
wet-bulb, °C	22.2
<i>Cooling Load Summary</i>	
people, persons	20
computers, pcs.	20
laser printers, pcs.	3
Fluorescent lights at the ceiling, kW	4
<i>Total load for the space</i>	
sensible, W	8711
latent, W	1172

Four system configurations were compared (three displacement and one mixing):

System 1 – Displacement, return from the upper zone, supply temperature 18°C (Figure 7)

System 2 – Displacement, return from the occupied zone, supply temperature 18°C (Figure 8)

System 3 – Mixing, return from the upper zone, supply temperature 14°C

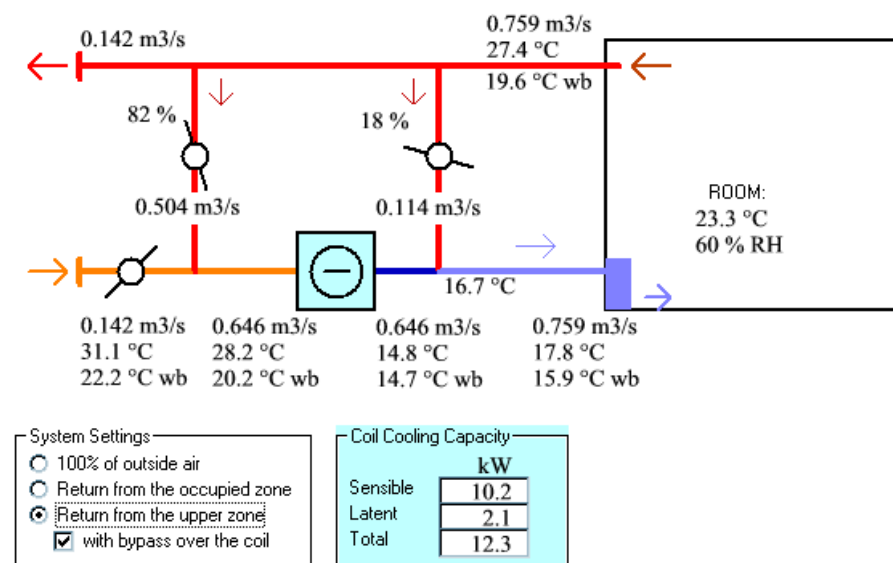

Figure 7. Printout of the Displacement Ventilation program. Return from the upper zone, supply air temperature 18°C

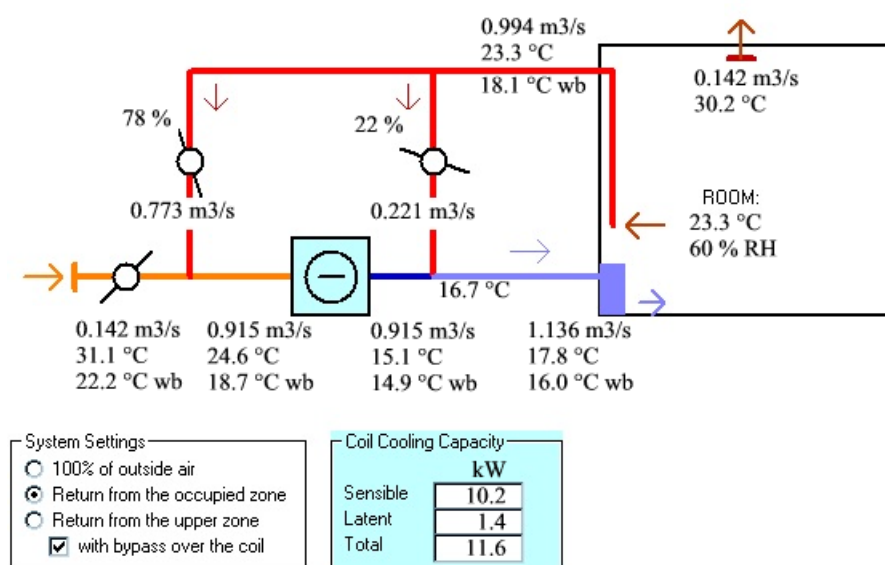

Figure 8. Printout of the Displacement Ventilation program. Return from the occupied zone, supply air temperature 18°C

Table 2 Calculation results

	Displacement with return from		Mixing with return from the upper zone
	upper zone	occupied zone	
System	1	2	3
<i>Design Conditions</i>			
Supply air temperature, °C	18	18	14
Supply airflow, m ³ /s	0.759	1.136	0.771
Exhaust / return air temperature, °C	27.4	30.2 / 23.3	23.3
Return airflow, m ³ /s	0.617	0.994	0.63
Air Changes, 1/h	4	6	4.1
<i>Chiller Cooling Capacity and Energy Consumption</i>			
Nominal cooling capacity, kW	12.3	11.6	13.7
Annual energy consumption, MWh	2.0	2.2	3.0
Cooling hours	801	801	1079

As seen from the calculation results in the Table 2, Displacement Ventilation with the supply air temperature 18°C (System 1) allows reducing the chiller cooling capacity by 1.4 kW and its annual energy consumption by 33 % compared to mixing ventilation system (System 3). Taking the return air from the occupied zone (System 2) allows further reducing the chiller cooling capacity due to the lower return air temperature. It is important to point out that System 2 will require higher supply airflow compared to System 1 as a result of higher temperature in the upper zone and higher radiation from warm ceiling back into the occupied zone.

7. CONCLUSIONS

1. Displacement ventilation systems allow reducing the cooling capacity and the annual energy consumption by the chiller for the high heat load applications.
2. Using displacement ventilation systems with return air allows for controlling the supply air moisture without increasing the system cooling capacity.
3. Thermal displacement ventilation systems allow moisture stratification in the space when water vapour follows convective plumes from the heat sources.
4. Additional measurement data is required to study displacement ventilation systems where the moisture sources are not associated with generation of heat.

NOMENCLATURE

A	area, m^2	f	floor
m	mass flow rate, kg/s	l_{oz}	load into occupied zone
Q	Heat flux, W	l_t	load total
q	volumetric flow rate, m^3/s	l_{uz}	load into unoccupied zone
T	absolute temperature, K	p	plume
t	temperature, $^{\circ}C$	r	room, occupied zone
σ	Stefan-Boltzmann constant $W/(m^2 \cdot K^4)$	ret	return air
ε	emissivity factor	s	supply
φ	view factor	wb	wet bulb

Subscripts

c_f	ceiling – floor
ex	exhaust

REFERENCES

- M. Conlin. Is Your Office Killing You? *Business Week*, June 5 2000, pp. 114-130.
- W. A. Turner. Advanced Ventilation Design for Commercial, Industrial and Institutional Facilities. *HPAC Engineering*, October 1999, pp. 61-66
- Livchak, R. Bagwell and R. Catan. Displacement Ventilation For a Better indoor climate. *Air Conditioning, Heating & Refrigeration News*, November 15, 1999
- Heiselberg, P. and Sandberg, M. Convection From a Slender Cylinder In a Ventilated Room. *Proceedings of ROOMVENT '90, Oslo*, 1990
- Shilkrot, E.O. and Zhivov, A.M. Zonal Model for Displacement Ventilation Design. *Proceedings of ROOMVENT '96, Japan* 1996