

# PolluStop 12000 CFM

PolluStop Advanced Air Purification Units

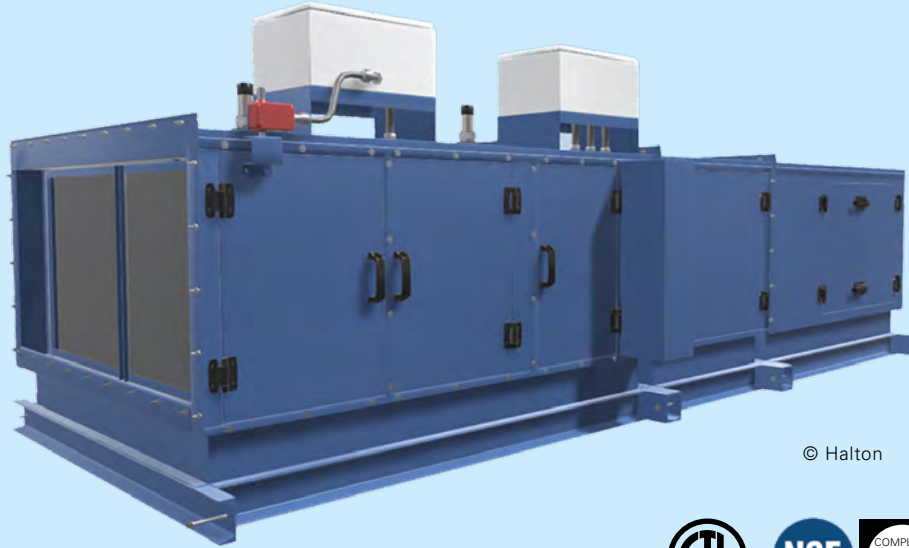

© Halton

Note: Above image if for illustration purposes only. It may reflect certain sizes or options. Refer to project approval drawings for specific PolluStop details.



## Features & Benefits

- First of its kind load dependent design with application specific filtration options.
- Explicitly developed for commercial kitchens operating in dense urban locations.
- Allows side wall discharge for exhaust ductwork.
- Minimize neighborhood restaurant exhausted cooking odors and maintain desired residential air quality standards.
- Electrostatic Precipitator module with washdown available for heavy grease and solid fuel applications.
- Automatic exhaust fan regulation ensures design exhaust volumes are always maintained.
- PolluStop operations can be integrated into one common control panel when Halton hoods and M.A.R.V.E.L. DCKV solutions are selected to support High Performance Kitchen designs.
- Heat Recovery (HRU) Module available. Connects to Halton supplied make up air unit with heat recovery coil.
- Integrated BMS monitoring and remote factory monitoring/control communication capabilities.
- Construction includes double wall heavy gauge shell construction with acoustic insulation for reduced sound levels.

## Application

PolluStop modules are designed to be incorporated into commercial kitchen ventilation systems where the control of airborne pollutants at the discharge point is a requirement. There are 10 standard capacities ranging in size from 3000 cfm to 24,000 cfm. Sizes up to 40,000 CFM are available, consult factory.

The PolluStop was developed to compliment the Capture Jet™ kitchen exhaust hoods or Ventilated Ceilings Systems.

## 12000 CFM PolluStop

PolluStop Advanced Air Purification Units

# ELECTROSTATIC PRECIPITATOR (ESP) MODULE

Single ESP Module shown.

Double Pass ESP Module is available.

## RH ELECTROSTATIC PRECIPITATOR MODULE

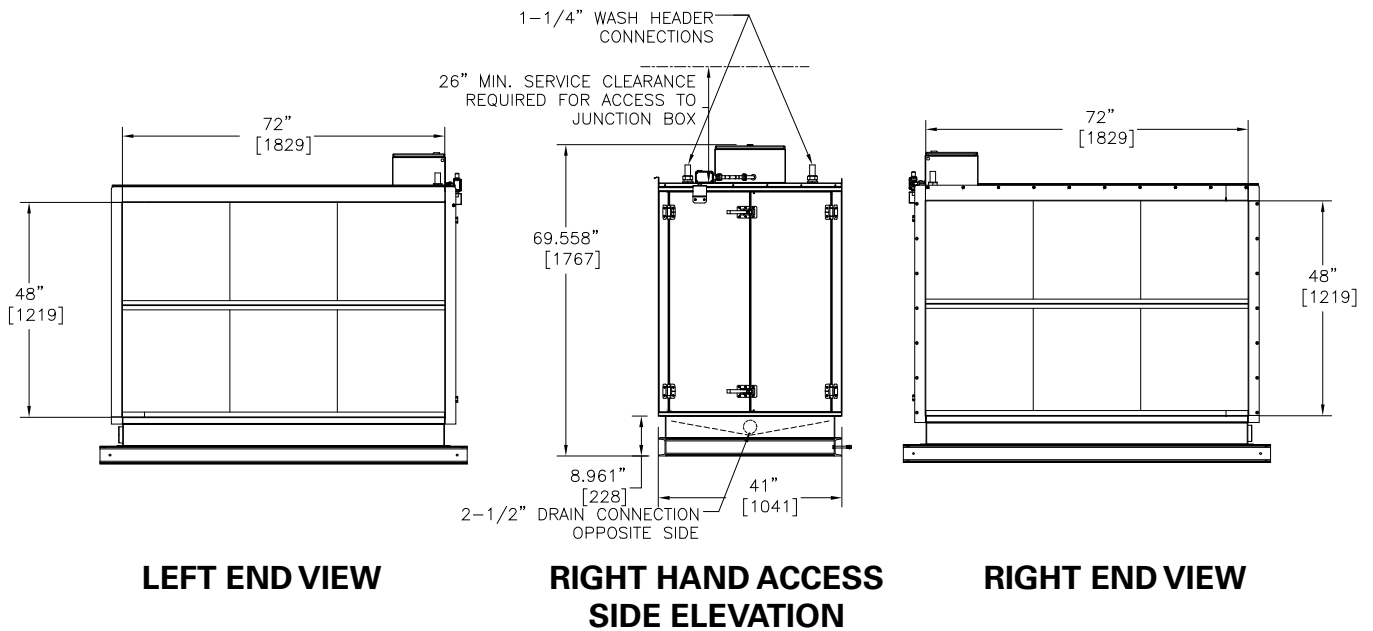
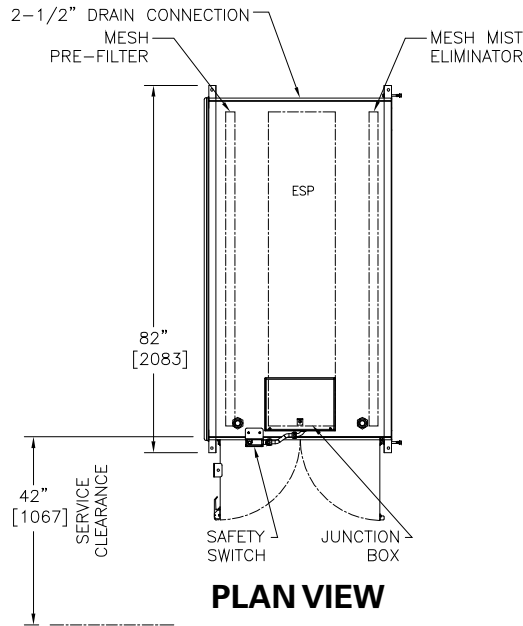

Form#: SS154\_1200CFM\_PolluStop  
Date: 05-2022 - Rev7

### 12000 CFM PolluStop

PolluStop Advanced Air Purification Units

**RH ELF FILTER MODULE**

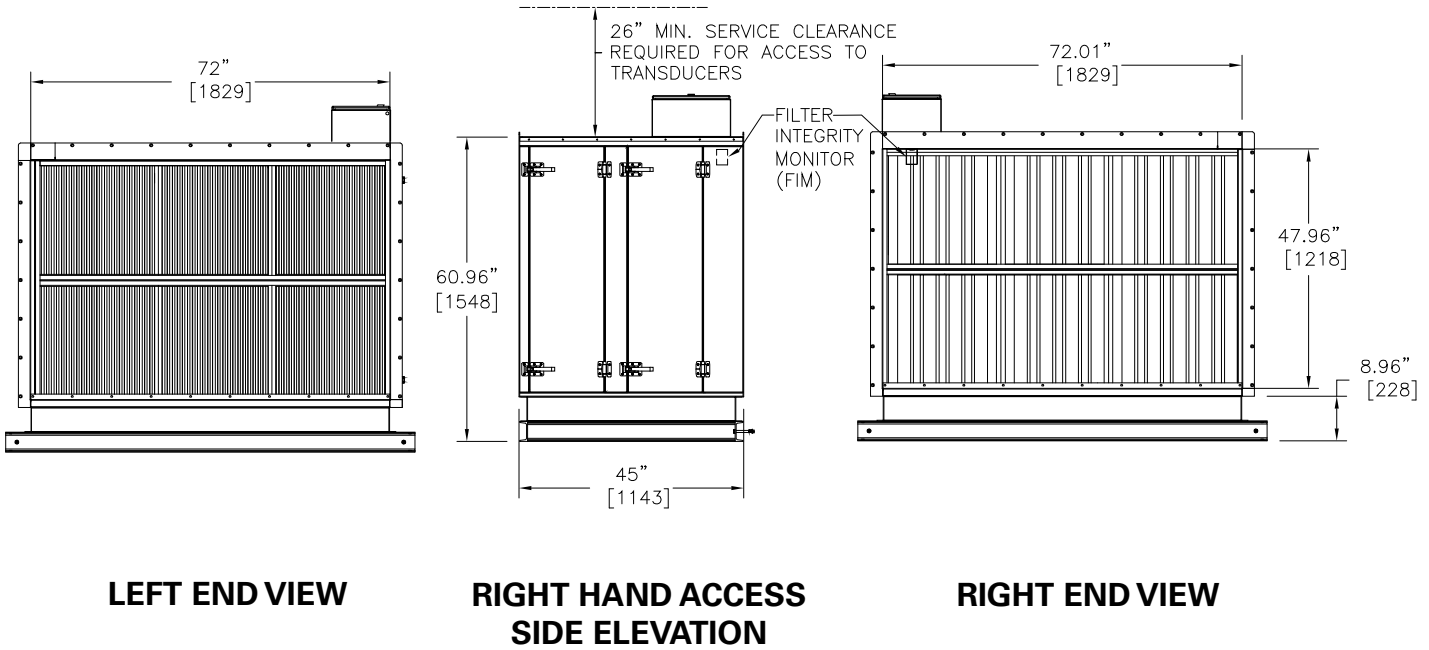
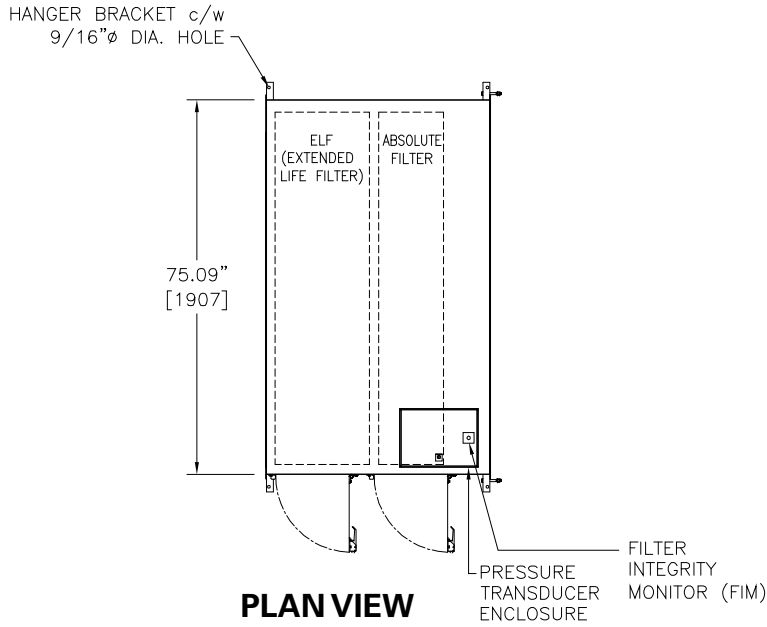

# ELECTROSTATIC PRECIPITATOR (ESP) WITH ELF MODULE

Module includes ELF (Extended Life Filter) and a ionizer-collector cell(s), mist eliminators, wash system and water wash drain pan.

Double Pass ESP Module is available.

## RH ELECTROSTATIC PRECIPITATOR WITH ELF MODULE

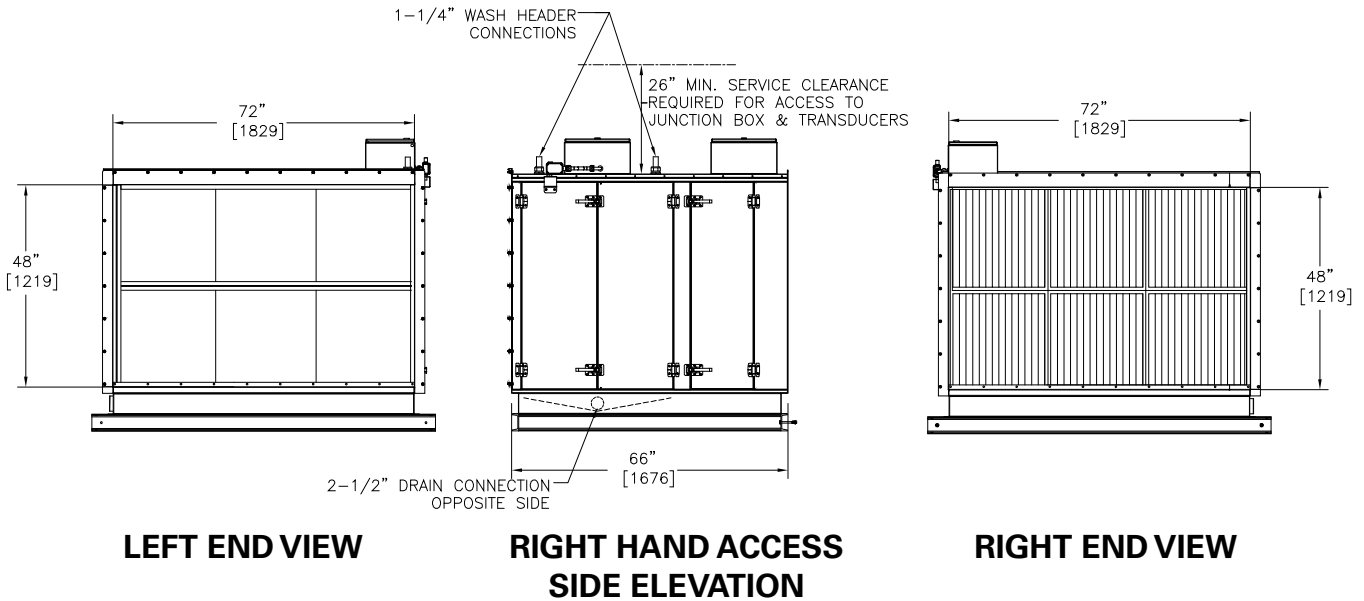
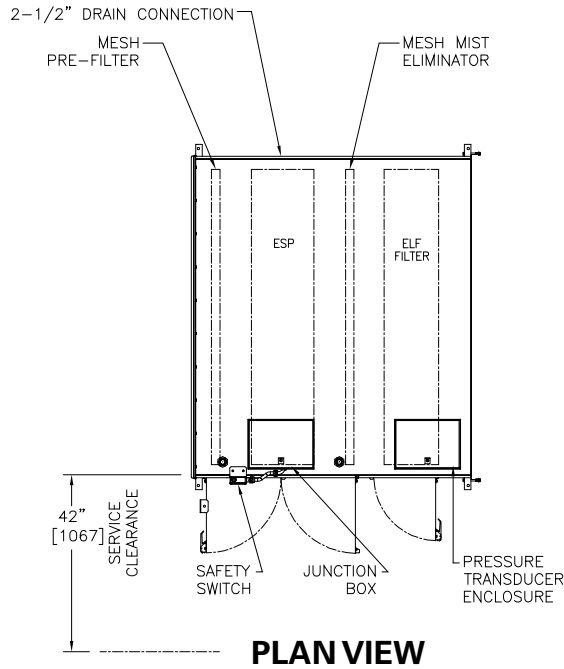

# HEAT RECOVERY MODULE

The heat reclaim module with heat transfer coil installed after the electrostatic precipitator or filter module sections to reclaim heat from the exhaust air stream. The loop is connected to a Halton make up air unit with its own heat transfer coil for providing pre-heat air to the make-up air unit during winter.

Form#: SS154\_1200CFM\_PolluStop  
Date: 05-2022 - Rev7

## RH HEAT RECOVERY MODULE

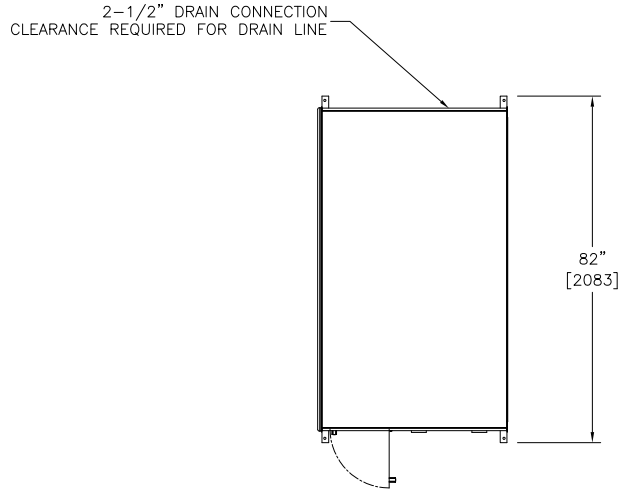

**PLAN VIEW**

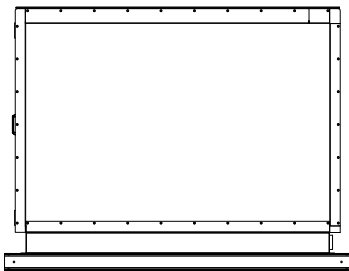

**LEFT END VIEW**

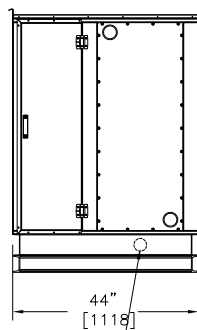

2-1/2" DRAIN CONNECTION  
OPPOSITE SIDE

**RIGHT HAND ACCESS  
SIDE ELEVATION**

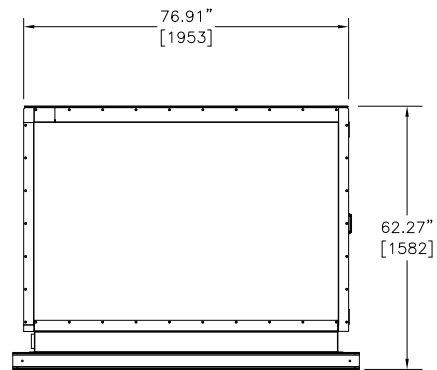

**RIGHT END VIEW**

## 12000 CFM PolluStop

PolluStop Advanced Air Purification Units

# ODOR SPRAY MODULE

The "Scentry™" liquid spray odor reducing system shall produce an atomized spray that permeates the filtered exhaust air to attack and mitigates airborne odors.

Form#: SS154\_1200CFM\_PolluStop  
Date: 05-2022 - Rev7

## RH ODOR SPRAY MODULE

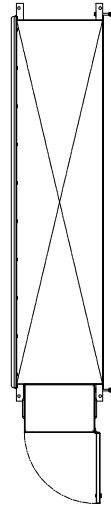

**PLAN VIEW**

POLLUSTOP ODOR CONTROL SYSTEM  
ENCLOSURE TO CONTAIN POLLUSTOP ODOR CONTROL, COMPRESSOR, NOZZLE AND "SCENTRY™" LIQUID CONTAINER

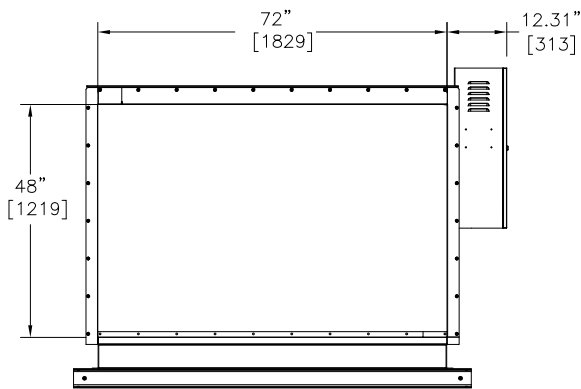

**LEFT END VIEW**

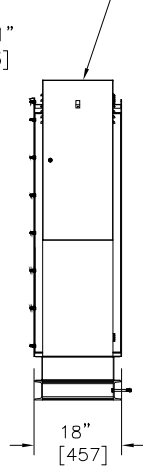

**RIGHT HAND ACCESS SIDE ELEVATION**

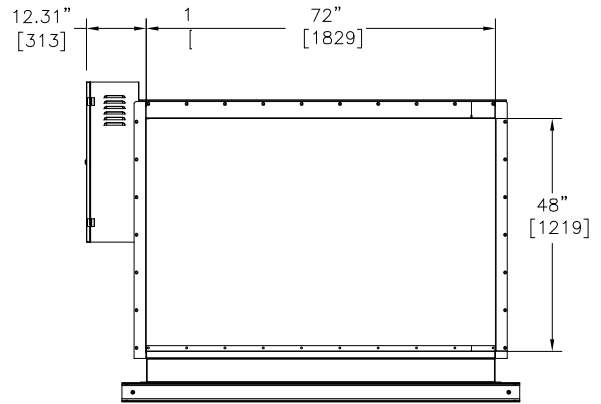

**RIGHT END VIEW**

## 12000 CFM PolluStop

PolluStop Advanced Air Purification Units

## CARBON PANEL MODULE

Panel of activated carbon for the absorption of odor.

2" Carbon panels with a UV module are standard.

1" Carbon panels without UV are optional.

Double Pass Carbon Panel Module is available.

### RH CARBON PANEL MODULE

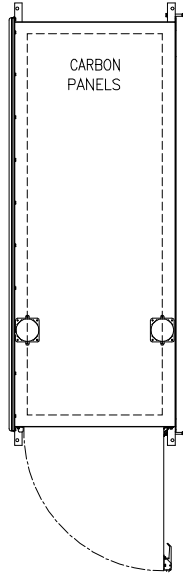

**PLAN VIEW**

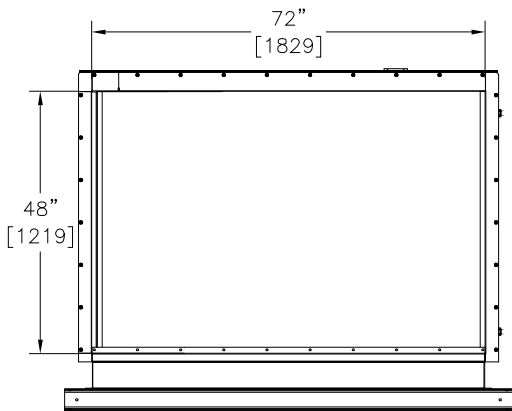

**LEFT END VIEW**

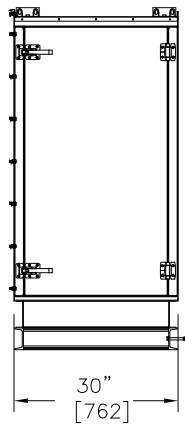

**RIGHT HAND ACCESS  
SIDE ELEVATION**

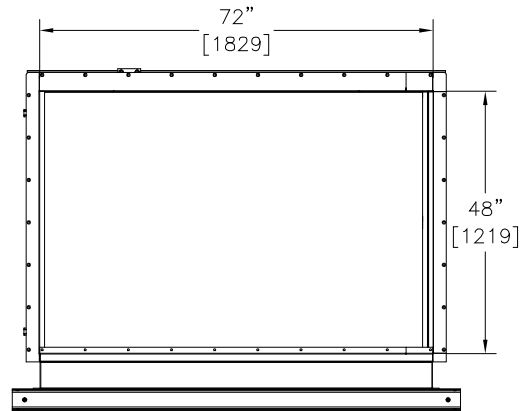

**RIGHT END VIEW**

## 12000 CFM PolluStop

PolluStop Advanced Air Purification Units

## UV CARBON MODULE

Module with UV-C bulbs in conjunction with carbon panels for odor critical applications.

Double Pass Carbon available with UV-C.

### RH UV CARBON MODULE

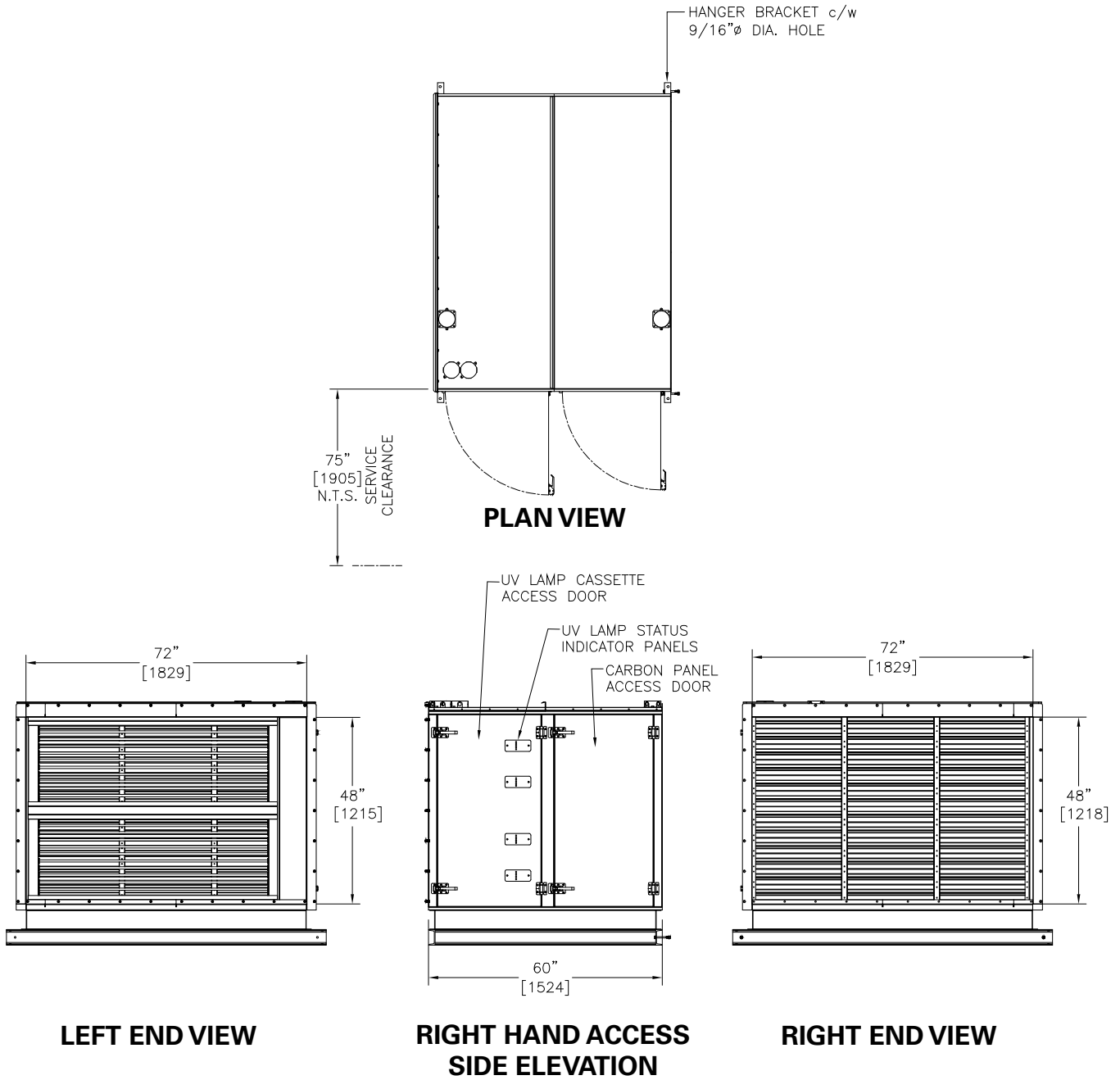



# BLOWER MODULE

## RH FAN MODULE

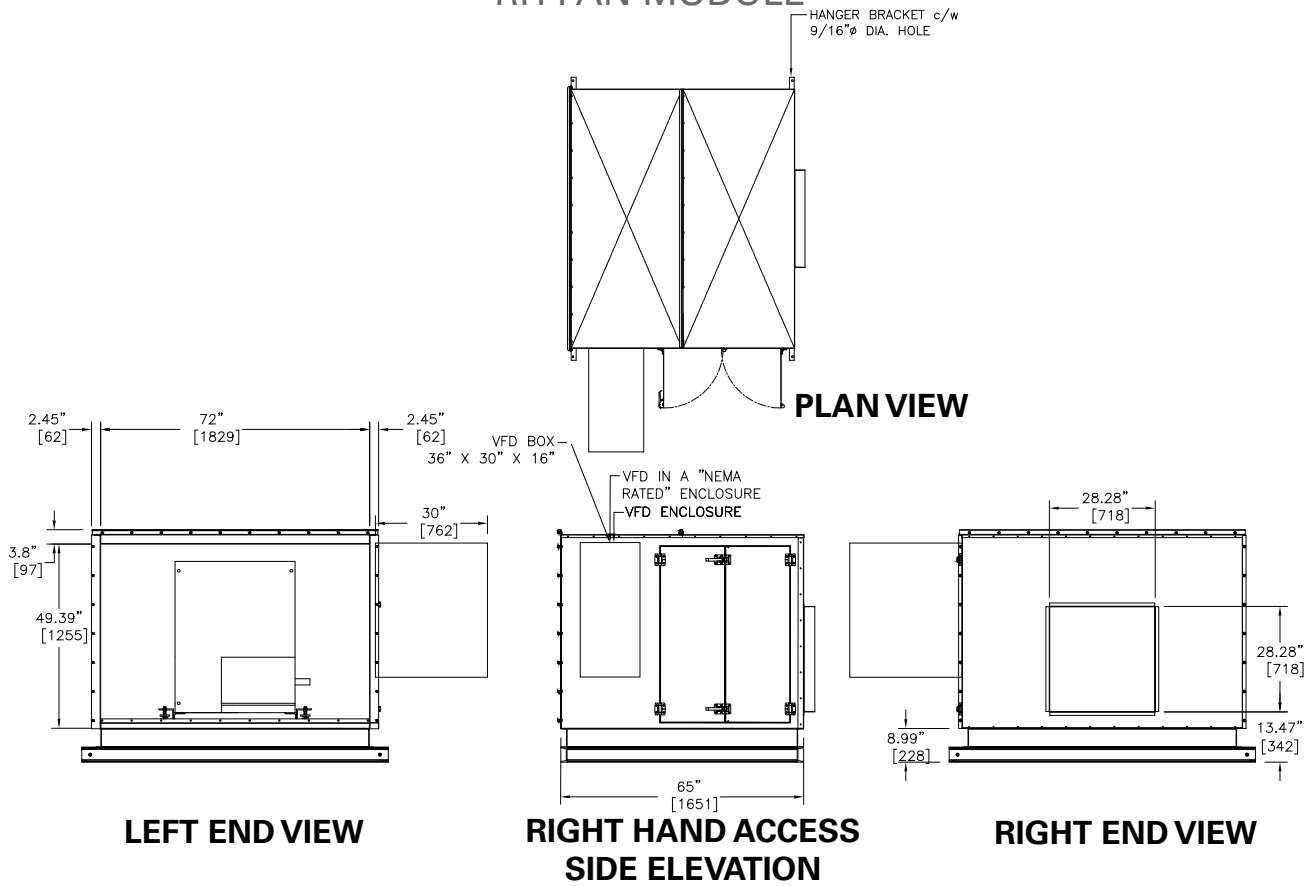

## OPTIONAL UPBLAST FAN

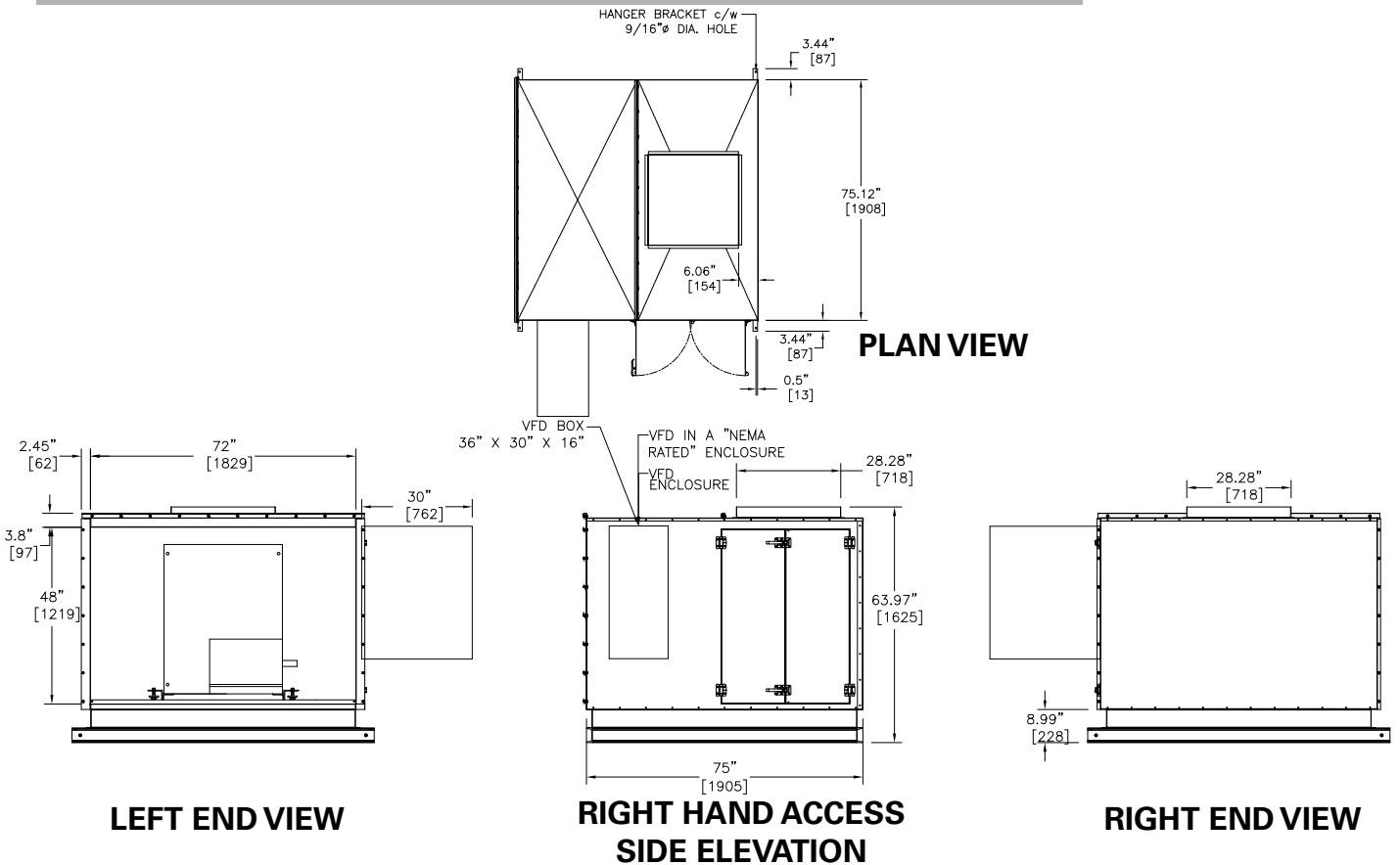

# 12000 CFM PolluStop

PolluStop Advanced Air Purification Units

**SILENCER MODULE - FULL SIZE**

Form#: SS154\_12000CFM\_PolluStop  
Date: 05-2022 - Rev7

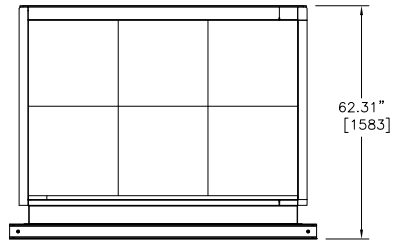
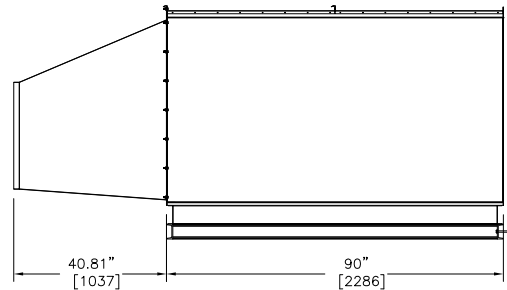
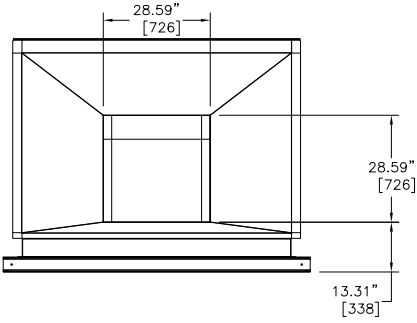
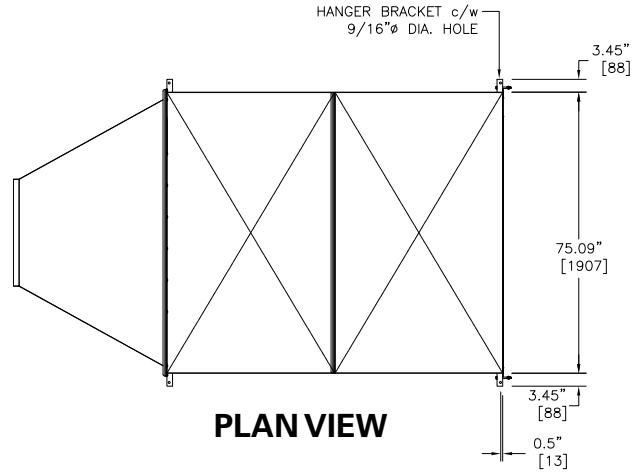

**SILENCER MODULE - HALF SIZE**

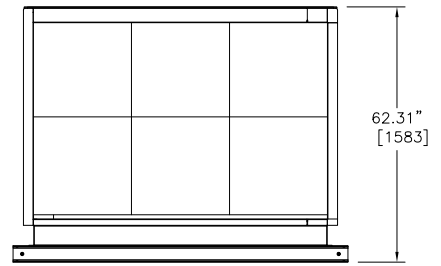
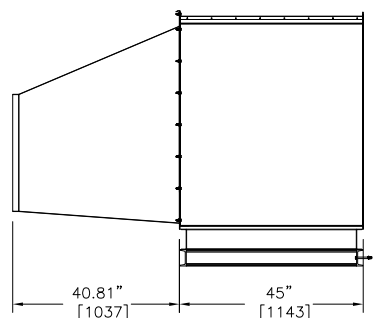
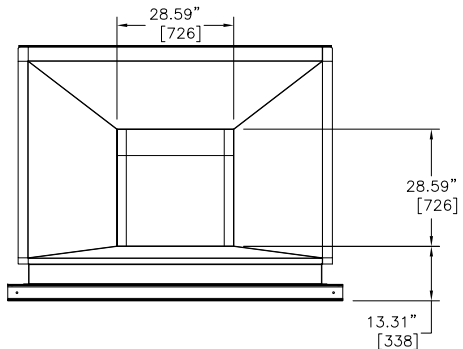
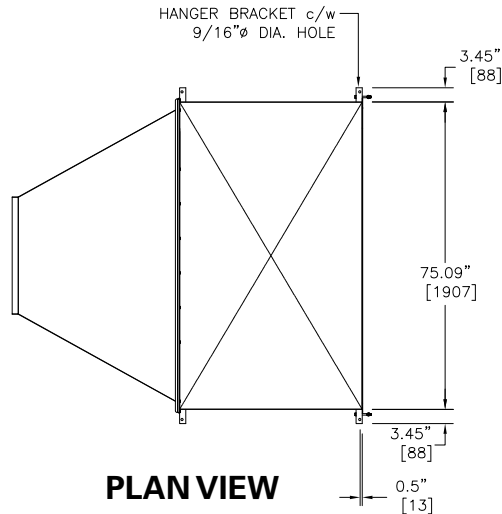

**12000 CFM PolluStop**

PolluStop Advanced Air Purification Units



## SILENCER MODULE

PD (Silencer) (in.w.g.)	L (in.)	Insertion Loss (dB)							
		63	125	250	500	1000	2000	4000	8000
0.12	90	11	18	22	24	25	26	17	10
0.12	45	6	10	12	13	13	13	10	7

### Consultant Specification

The PolluStop System is Listed to U.L. Pollution Control Standard 8782 and shall be a Model \_\_\_\_\_, as manufactured by Halton, supplied complete with Filter and or Electro-Static Precipitator(ESP) Module, Odor Module, Fan Module, and Control Panel. System mounting to be designed for; Interior/Exterior, Suspended/Floor/Roof.

The system shall deliver \_\_\_\_\_CFM( \_\_\_\_\_)with efficiency of at least 95% at 0.4 microns m3/s) at \_\_\_\_\_ in.w.g. ( \_\_\_\_\_ Pa) External Static Pressure. The Halton PolluStop unit shall be ETL Listed.

The Filter, Electro-Static Precipitator (ESP) and Odor modules shall have a 16 ga. Interior and minimum 20 ga. Exterior shell and include a side access door mounted with hinges and over center lever closure latches. The Electrostatic Precipitator (ESP) section access door shall be furnished with electrical interlock. The housing shall be permanently attached and supported by a 4" C-Channel x 4.5 lbs/ft steel channel perimeter base. The base shall have integrated holes for mounting and lifting. The base and external housing shall be pre-treated and powder coated with thermoset polyester paint. The PolluStop unit shall contain the following sections to make up a complete system.

### ELF FILTER MODULE

The unit casing shall be fully painted and be a double wall construction reinforced and braced for maximum rigidity. Inner walls shall be 16-gauge liquid tight welded and construction and outer walls shall be minimum 20-gauge steel. Filter sections to be insulated with 1" (25.4mm) insulation to the requirements of UL/ULC. The entire unit will be mounted on a 4" x 5.4 lb/ft. structural steel support base. The unit shall be complete with two stages of filtration.

- The first stage filter shall be a 15" deep combination Extended Life Filter, MERV 14 rated and classified to UL 900 standard. The filter clean resistance will not exceed 1.04" w.g. and have an overall holding capacity of 7.9 lbs with a nominal face area of 24 x 24 inches. A combination of a MERV 8, 2" pleated filter and MERV 14 Bag filter shall not be used.
- The second stage filter shall be a 12-inch deep Mini-Pleat V-Bank MERV 16 performance per ASHRAE 52.2 and classified to UL900 standard. The filter clean resistance shall not exceed 0.6 in.w.g.

Filter module will include a grease monitoring system that detects when grease bypassing the final filter in the Halton PolluStop system. This module to be complete with pressure transducers to monitor the condition of each of the stages of filtration, and a pressure transducer to monitor overall airflow cfm. Hinged access doors shall be provided to allow easy access to the filters. It shall detect if the absolute filter in the PolluStop unit is partially missing due to filter gaps or if a lower alternative manufacturers efficiency final filter is being used.

An optional UL/ULC Listed fire damper actuated by fusible link (212°F UL / 212°F ULC) may be located at the outlet.

Note: This equipment may ship in sections. Additionally, if the arrangement presents issues with onsite access or rigging into place the unit can be custom fabricated.

### ESP MODULE

This module shall be engineered and fabricated to structurally house and support mesh pre-filters, ionizer- collector cells, safety filter, mist eliminators, wash system and water wash drain pan.

**Pre Filter** shall be 2" thick, constructed of aluminum frame and non-woven aluminum mesh filter media with a minimum of MERV rating of 7.

### **Ionizer-Collector**

The second stage filtration shall c. Ionizer-collector cells shall be the industrial type, single unit construction. Cells shall be 3003-H14 aluminum construction except: ionizer discharge electrodes are the 316 stainless steel rigid type. Tungsten wire electrodes are not acceptable. Ionizing discharge electrode shall be lifetime guarantee. Repelling and collector plates and ionizer ground plates are positively retained in place using tie rod and tubular spacer design. Repelling and collector plates shall be 0.32" minimum thickness. High voltage insulators, molded from structural self-glazing ceramic, shall contain no appurtenances; are of radial and bilateral symmetry; contain no high voltage penetrations and do not expose high voltage on the process air side. Insulators have a voltage to ground, track distance, of 2.60", and shall be lifetime guarantee against electrical tracking. Cell high voltage interconnection is made automatically be flexible stainless-steel contacts, when cells are in position. Coiled spring contacts are not acceptable.

### **High Voltage Power Pack**

The system control and high voltage power pack shall be furnished in separate enclosures for remote mounting, indoors. The system control shall be located where it can be easily monitored. The power pack shall be located where it is accessible for maintenance and adjustments. Furthermore:

- A. A programmable logic controller shall be furnished to sequence the precipitator through individual wash cycles as scheduled in the controller programming following shutdown of the exhaust hood. The control is furnished with an integral, electronic timer with override to manually sequence the wash cycle. The face panel of the enclosure shall contain an HMI touch screen interface to indicate RUN or WASH status and individual power pack PRIMARY and SECONDARY POWER. An ON/OFF switch for the power packs is furnished on the screen. Controller shall be web enabled, allowing for remote monitoring and BMS communication (optional). Enclosure is NEMA 1 rated.
- B. The High voltage power supply shall be the solid-state pulse type, providing an adjustable output of 10.0/5.0 to 12.0/6.0 kVdc. The power supply input and output shall be internally regulated for line fluctuations of +10% and have a current limiting shutdown.

**Wash System** A water/detergent washing system shall be furnished to automatically clean the ionizing-collecting cells. The wash system is the high pressure, low volume type, designed to operate with a 140°F/50 psi hot water supply. Detergent, hot wash and rinse water are applied by copper manifolds located on the air entering and air leaving side of each cell tier. Front and rear manifold direct spray towards the cell.

Copper manifolds with brass spray nozzles shall produce a positive fan shaped spray pattern towards the ionizer-collector cells. Each manifold shall contain a clean out plug. Furnish a pivoting drive linkage connecting the drive motor to the manifolds. The wash system shall be factory installed as an integral part of the precipitator side access housing.

Following the final wash nozzles, a 2" thick, moisture eliminator shall be furnished to contain wash water overspray.

**Drain Pan** shall be sloped ¼" per linear foot and shall terminate through a 2-1/2" NPT female coupling.

**Detergent Dispenser** shall be furnished including a (specify) 55, 100 or 260 gallon detergent polyethylene reservoir, pump, motor, flow volume control valve, low level detector and ½" Type M copper tubing. The pump shall be the positive displacement, self-priming, rotary vane type with carbon graphite pump chamber, 316 SS shaft and built-in relief valve pre-set at 170 psi. Motor shall be ½ HP, split phase, ODP type with thermal protection, NEMA 48Y frame and shall operate on 100-120/200-240 VAC, 50/60 HZ, 1 PH. A volume of detergent concentrate, equal to the reservoir capacity, shall be included. During system commissioning dispenser shall be adjusted to an output of 1:20 detergent to water ratio.

### **Brass Plumbing Components**

Required for operation of the wash water inlet supply line, shall be factory furnished for installation by the installing contractor as follows: ball valve; double independent check valve type backflow preventer; pressure gauge; electric solenoid valve and wye strainer. These components shall be sized to accommodate the water flow rate of the wash system. A ½" brass ball valve shall be furnished for installation in the detergent dispenser outlet line.

**Mist Eliminators** shall be 2" thick, constructed of aluminum frame and non-woven aluminum mesh filter media with a minimum of MERV rating of 7.

**Safety/ELF (Extended Life Filter)** shall be a 15" deep, MERV 14 rated and classified to UL 900 standard. The filter clean resistance will not exceed 1.04" w.g. and have an overall holding capacity of 7.9 lbs. A combination of a MERV 8, 2" pleated filter and MERV 14 Bag filter shall not be used.

**HEAT RECOVERY COIL**

The pollution control unit shall have a heat reclaim module with heat transfer coil installed after the electrostatic precipitator or filter module sections to reclaim heat from the exhaust air stream. The coil shall have copper tubes and aluminum fins and have headers that allow it to be connected to a run-around glycol system. The loop is connected to a Halton make up air unit with its own heat transfer coil for providing pre-heat air to the makeup air unit during winter.

**ODOR CONTROL MODULE SELECTION**

The PolluStop Odor Control Module shall consist of a housing and a self-contained odor reducing system of one of the following:

- **Odor Spray:** The housing shall be fully painted and be constructed of 16 ga. (minimum) steel with all joints suitably reinforced and braced for rigidity. The "Scentry™" liquid spray odor reducing system shall produce an atomized spray that permeates the filtered exhaust air to attack and neutralize airborne odors. The system housing shall be constructed of heavy steel with locking hinged access door and two security bolts. The system shall be complete with an atomizing spray nozzle, 5-gallon liquid reservoir. Timers mounted in the PolluStop control panel to switch on, off and cycle control to provide for infinite adjustment.
- **Activated Carbon Panels** - Furnished in a panel with galvanized steel perimeter frame, covered on both sides with perforated plate and enamel painted. Carbon is composed of virgin coconut shell granular activated carbon with a minimum carbon tetrachloride activity of 60% per ASTM D-3467, is 4 x 8 US mesh size, and impregnated with active ingredients to enhance cooking odor molecule removal. Carbon shall have a bulk density of 30 lbs/ft.<sup>3</sup> and sized for a minimum gas residence time of 0.15 seconds (applied at the rate of 95 lbs/2000 cfm of exhaust air). Carbon panels shall be held in place by extruded aluminum tracks, integral to the housing. Tracks shall contain flexible, bulb seal gasketing to eliminate air bypass. As an option, other formulations of sorbent media may be furnished as specified.
- **UV Carbon Module** - The odor control section shall consist of two parts: first a set of UV lamps arranged in a perpendicular plan to the airflow followed by carbon panels. The quantity of UV lamps shall be 12 per nominal

2,000 cfm of exhaust air. The carbon panels shall contain coconut shell activated carbon with a nominal density of 30 pounds per cubic foot. The minimum amount of carbon in a unit shall not be less than 95 pounds of carbon per nominal 2,000 cfm of exhaust air.

The UV lights shall be powered by dedicated UV ballasts and the ballasts shall be provided with ventilation air.

**FAN MODULE**

The exterior fan housing shall be fully painted and be constructed from 16 ga.(minimum) steel with all joints suitably reinforced and braced for rigidity. The fan shall be AMCA rated be a DWDI (double width, double inlet), Class 2, backward inclined, with airfoil type blades and with non-overloading characteristics. The complete fan assembly is statically and dynamically balanced. The shaft is ground and polished steel. Bearings shall be pillow block type with lubrication nipples. Drives shall be V belt or grip notch with capacity 25% greater than motor horsepower. The fan and motor shall be mounted on a common base which is spring vibration isolated from the fan housing. A fire stat shall be located at the fan inlet to stop the fan on high air temperature. Hinged access doors shall be provided to allow easy access to fan and motor. Units to be complete with a \_\_\_\_\_HP (\_\_\_\_\_kW)\_\_\_\_\_ Volt\_\_\_\_\_ Phase Hz motor, motor starter complete with electrical overloads and electrical disconnect switch.

**Fan Options:**

Blower shall be AMCA certified, belt driven utility set or mixed flow tubular type as specified, UL 762 listed and sized to perform the specified air volume and resistance to air flow. The blower shall operate on (specify)\_\_\_\_\_volts, \_\_phase, \_hertz and shall be mounted on 1" deflection, restrained spring isolators. Blower motor control shall be either motor starter or variable frequency drive (specify).

**SILENCER MODULE**

The Silencer Module housing shall be fully painted and be double wall constructed with all joints suitably reinforced and braced for rigidity. Inner walls shall be 16 ga. liquid tight welded construction and outer walls shall be a minimum of 18 ga. steel. Silencer module will include acoustic grade glass fiber and utilize acoustical splitters (size dependent). Perforated metal is filmed lined that protects the glass fiber. The film shall have a Flame Spread index of 0 and Smoke Development of 15 as tested in accordance with ASTM E84, exceeding the NFPA 90A maximum requirements. (Module not provided with access doors.)

## CONTROL PANEL

The control panel shall be constructed from heavy gauge stainless steel and be suitable for surface mounting, remote mounting or recessed wall mounting with front locking screws. Controls shall be complete with touch screen and display will indicate system operational status, condition of both filter stages, percent (%) filter loaded for each stage, water wash controls, fan speed, fire condition and odor reducing operation. Controls and interconnecting field wiring to be standard 120 volt AC.

## CONSTANT VOLUME CONTROL

ECO-system will be standard with constant volume PolluStop systems and will consist of pressure transducers, a microprocessor and VFD. On start up, the main pressure transducer is calibrated with the Capture Jet™ Testing and Balancing Ports to design airflow. The setting will be stored in the system memory and acts as the reference point for design exhaust. The Microprocessor will read the signals from the pressure transducer and control the VFD to maintain constant airflow in the system. The VFD (Variable Frequency Drive) will control the RPM of the fan module based on the signal received from the microprocessor.

## MODIFICATIONS & OPTIONS

### GENERAL

- Weather Proof Insulation Package
- Rear Access Doors
- Inlet Transition
- HEPA Filter (smoke critical applications)
- UL/ULC Listed fire damper
- Fire Suppression System

### ELF FILTER MODULE

- Extra Set of Filters
- Visual indicator for filter loading
- FIM - Filter Integrity Monitor

### ODOR CONTROL MODULE

- Cold Climate Insulation
- Extra Container of Odor Solution

## VARIABLE VOLUME CONTROL

M.A.R.V.E.L. common controls platform is a custom programmed demand control system that provides for the complete and independent modulation of exhaust air volumes utilizing a single PolluStop unit. All functions of the PolluStop and controls system shall be of one manufacturer and a single control system. Multiple controls platforms field integrated shall not be used. The system shall allow operating each hood section independently utilizing a single exhaust fan as shown on contract drawings by use of UL Listed.

### FAN MODULE

- Acoustic Insulation Package
- International Voltages
- Single Phase Motor
- Internal Seismic Isolators
- Top Discharge
- Variable Frequency Drive (VFD)

### M.A.R.V.E.L. DEMAND CONTROL SYSTEM

- Variable volume control system with common controls platform
- HMI touch screen

The company has a policy of continuous product development, therefore we reserve the right to modify design and specifications without notice.

For more information, please contact your nearest Halton agency. To find it: [www.halton.com](http://www.halton.com)