

## BDH BLAST PROTECTION DAMPER

For offshore, onshore and heavy industry ventilation systems



### MATERIALS

PART	MATERIAL	FINISHING
Frame	Carbon steel	Painted or hot-dip galvanised
Frame	Stainless steel EN 1.4404 (AISI 316L)	-
Blades	Carbon steel	Hot-dip galvanised
Blades	Stainless steel EN 1.4404 (AISI 316L)	-
Setting, closing and locking mechanism	Stainless steel EN 1.4404 (AISI 316L)	-
Maintenance-free bearings	Stainless steel EN 1.4404 (AISI 316L)	-
Shafts	Stainless steel EN 1.4404 (AISI 316L)	-
Debris catcher	Carbon steel	Hot-dip galvanised
Debris catcher	Stainless steel EN 1.4404 (AISI 316L)	-

### APPLICATIONS

Halton BDH blast dampers protect against overpressure in offshore, onshore and heavy industry ventilation systems. The BDH blast damper can be installed in rectangular ducts or wall openings. When the blades are in the open position, the device does not cause significant pressure loss, noise or flow disturbance. The BDH has an adjustable arming mechanism to cope with different air velocity and closing pressure requirements. An open-closed indicator is visible on the outside of the damper. There is no external power source needed to operate the damper. In case of a blast incident, the pressure wave closes the blades. There is a locking mechanism preventing the blades from opening during the negative phase. After a blast incident, the blades remain locked in the closed position, until the damper is set (armed) again.

### FEATURES

- Shock tube tested for detonation (shock) type pressure wave
- Shock tube tested for deflagration (blast) type pressure wave
- Shock tube testing in compliance with GSA TS01 and ASTM F 1642-04(2010)
- Debris (steel balls and wood plank missile) impact tested
- Debris impact testing in compliance with ASTM E 1886-13a and ASTM E 1996-14a
- Aerodynamic testing according to EN 1751
- The normal open position of the blade angle is 45 degrees
- ATEX certified
- Recommended maximum air velocity is 10 m/s
- Maximum shock and blast wave pressure is 1.0 bar
- The normal operating temperature for a stainless steel damper is between -60 °C to +80 °C
- The normal operating temperature for a carbon steel damper is between -20 °C to +80 °C

GENERAL BDH DRAWINGS

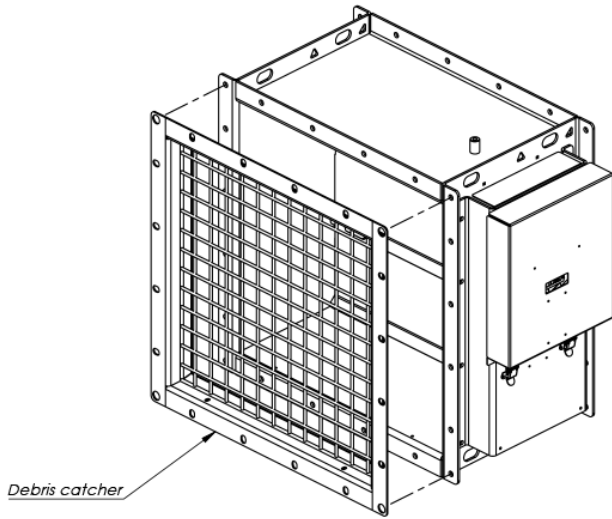

Debris catcher

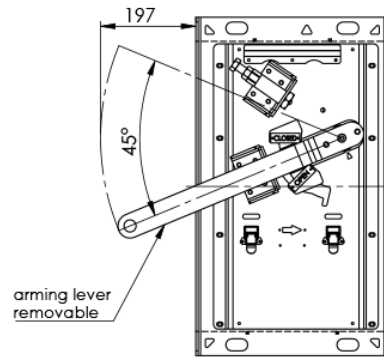

arming lever removable

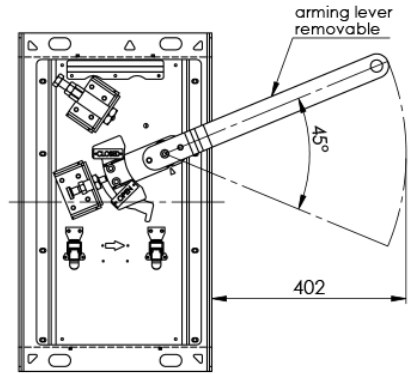

arming lever removable

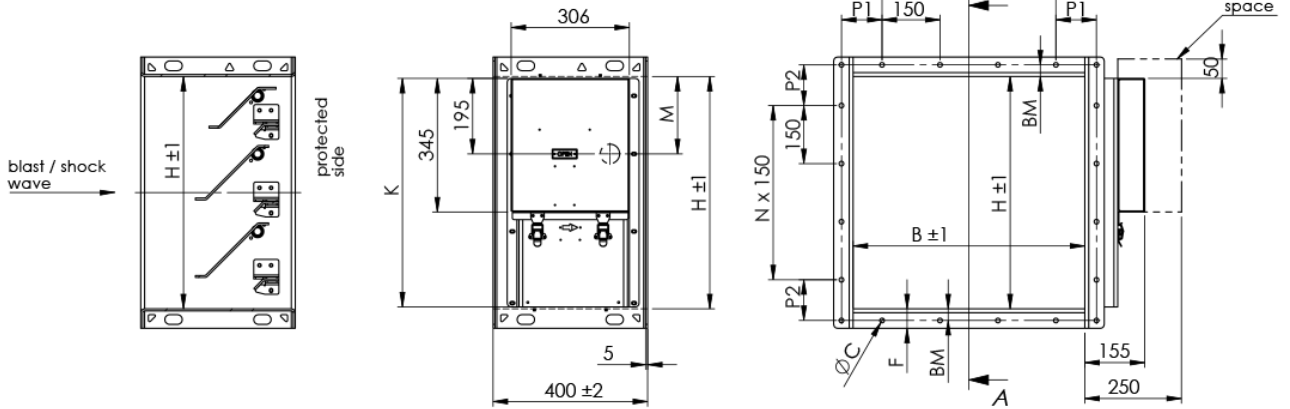

H	M	K
1200	200	1190
1150	200	1140
1100	200	1090
1050	200	1040
1000	200	990
950	200	940
900	200	890
850	200	840
800	200	790
750	200	740
700	200	690

H	M	K
650	200	640
600	200	590
550	200	540
500	200	490
450	250	440
400	200	435
350	200	435
300	50	440
250	50	435
200	50	435

Damper size BxH	Opening size steel wall / duct coaming (max) BxH
300x300	300x300
400x400	400x400
500x500	500x500
600x600	600x600
700x700	700x700
800x800	800x800
900x900	900x900
1000x1000	1000x1000
1100x1100	1100x1100
1200x1200	1200x1200

FLANGE DIMENSIONS ACCORDING TO ISO 15138

DIMENSIONS	ØC	Bolt	P1, P2	BM	F
If longest side ≤ 350	10	M8	75...150	20	40
If longest side 351...1000	12	M10	75...150	30	50
If longest side ≥ 1001	14	M12	75...150	40	80

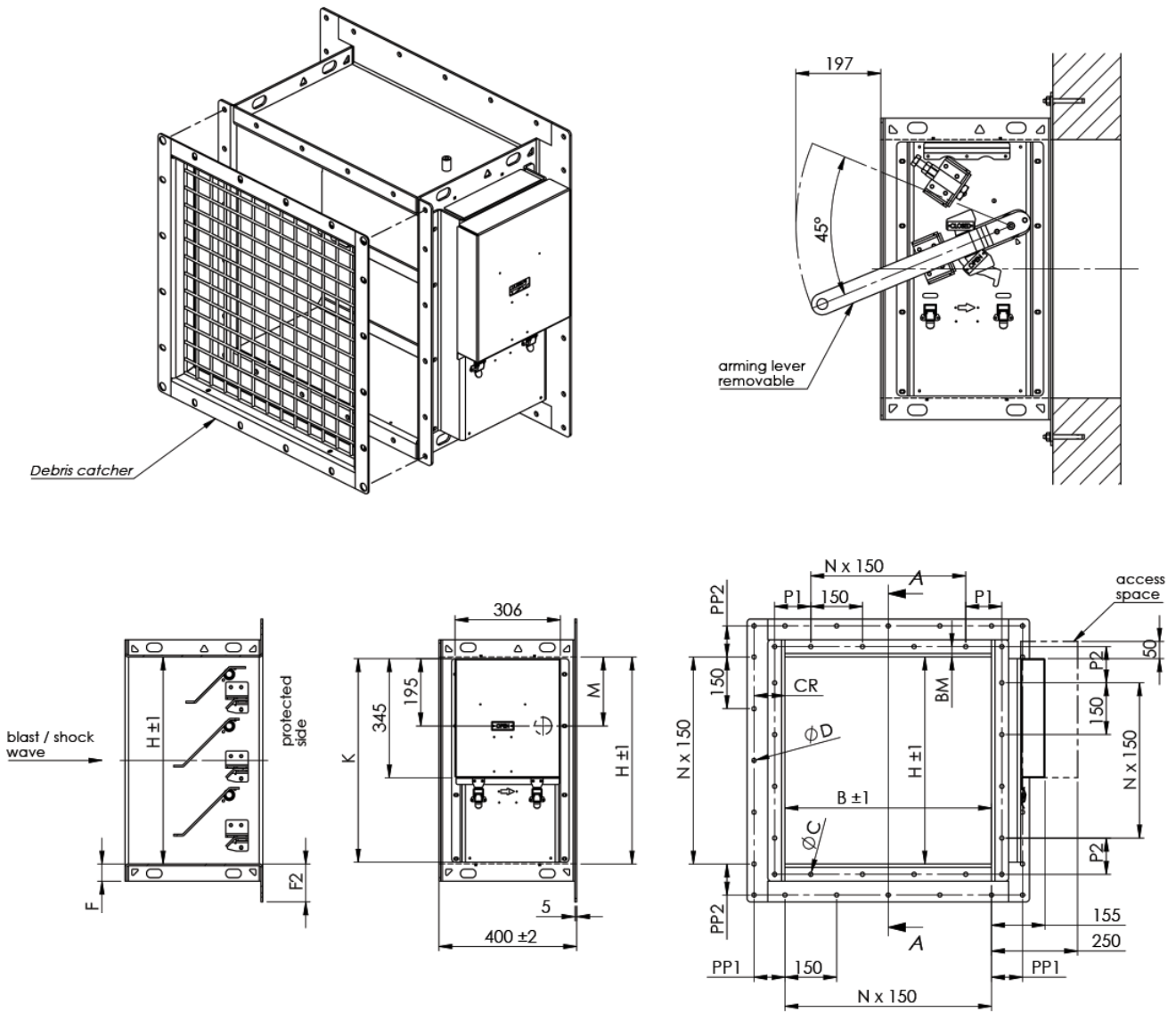

H	M	K
1200	200	1190
1150	200	1140
1100	200	1090
1050	200	1040
1000	200	990
950	200	940
900	200	890
850	200	840
800	200	790
750	200	740
700	200	690

H	M	K
650	200	640
600	200	590
550	200	540
500	200	490
450	250	440
400	200	435
350	200	435
300	50	440
250	50	435
200	50	435

Damper size BxH	Opening size concrete wall BxH
300x300	300x300
400x400	400x400
500x500	500x500
600x600	600x600
700x700	700x700
800x800	800x800
900x900	900x900
1000x1000	1000x1000
1100x1100	1100x1100
1200x1200	1200x1200

FLANGE DIMENSIONS ACCORDING TO ISO 15138

DIMENSIONS	ØC	Bolt	P1, P2	BM	F	P1, P2	CR	F2
If longest side ≤ 350	10	M8	75...150	20	40	75...150	75	95
If longest side 351...1000	12	M10	75...150	30	50	75...150	90	110
If longest side ≥ 1001	14	M12	75...150	40	80	75...150	105	145

**BDH DIMENSIONS AND MATERIAL THICKNESS**

BDH blast protection dampers are available for rectangular ducts and wall openings. Width B is 300-1200 mm, 25 mm division. Height H is 200-1200 mm, 50 mm division. Modular construction is available for larger sizes.

As a standard, flange width and bolt hole drilling are according to ISO 15138 standard.

Frame depth is 400 mm, frame thickness is 5 mm.

Blade thickness is 5 mm, blade shaft diameter is 25 mm.

Blades are bolted to shafts.

The damper has 1-6 blades. In a multiblade damper (2-6 blades), blades are connected via linkage and operate in parallel. Linkage thickness is 8 mm.

The debris catcher is a diameter of 6 mm wire. The open area between wires is 40 x 40 mm.

**BDH INSTALLATION OPTIONS**

The damper can be installed vertically outside of the building wall or between duct flanges. Also, horizontal installation is possible on the duct, floor or roof but only in the top-down blast direction.

The wall (or floor/roof) material can be concrete or steel.

For concrete wall installation, a wide-flange version is used and the damper is installed using anchor bolts.

For steel wall installation, the damper is installed using bolts or by welding.

Detailed installation information is available in the BDH installation, operation and maintenance manual.

**ACCESSORIES**

Arming tool to open the damper, at least one tool per building.

Debris catcher to prevent large objects from entering the protected area.

Mesh finger guard for personnel safety to prevent touching armed blades. Can be installed on the protected side, exposed side or both.

**WEIGHTS****STANDARD HALTON MARINE BDH DAMPERS (KG)**

H/HEIGHT mm	B / WIDTH (mm)									
	300	400	500	600	700	800	900	1000	1100	1200
200	41	43	46	49	52	55	57	60	63	66
300	52	56	60	63	67	71	75	79	83	87
400	63	68	73	78	83	88	93	98	103	108
500	74	80	86	92	99	105	111	117	123	129
600	85	92	100	107	114	122	129	136	143	151
700	96	105	113	122	130	138	147	155	164	172
800	107	117	126	136	146	155	165	174	184	193
900	122	133	143	154	165	175	186	197	207	218
1000	133	145	157	168	180	192	204	216	227	239
1100	144	157	170	183	196	209	222	235	248	260
1200	155	169	183	197	211	226	240	254	268	282

**STANDARD HALTON MARINE BDH DAMPERS FOR CONCRETE WALL (KG)**

H/HEIGHT mm	B / WIDTH (mm)									
	300	400	500	600	700	800	900	1000	1100	1200
200	44	47	50	53	56	59	62	65	68	71
300	55	60	64	68	72	76	80	84	89	93
400	67	72	78	83	88	94	99	104	110	115
500	79	85	92	98	105	111	118	124	131	137
600	90	98	106	113	121	129	136	144	152	159
700	102	111	120	129	137	146	155	164	173	181
800	114	124	134	144	154	164	174	184	193	203
900	129	140	151	162	173	185	196	207	218	229
1000	141	153	165	177	190	202	214	227	239	251
1100	152	166	179	193	206	219	233	246	260	273
1200	164	179	193	208	222	237	252	266	281	295