

BRD PRESSURE-RELIEF DAMPER

For offshore and marine ventilation systems



MATERIALS

PART	MATERIAL	FINISHING
Frame	Carbon steel	Painted or galvanised
Frame	Stainless steel EN 1.4301 (AISI304), EN 1.4404 (AISI316L), EN 1.4432 (AISI316L)	-
Blades	Steel	Galvanized
Blades	Stainless steel EN 1.4301 (AISI304), EN 1.4404 (AISI316L), EN 1.4432 (AISI316L)	-
Maintenance-free bearings	Stainless steel EN 1.4404 (AISI316L)	-
Shafts	Stainless steel EN 1.4404 (AISI316L)	-

BRD PRODUCT OPTIONS

- Models for horizontal and vertical installation available
- Circular connection pieces are available.
- Standard construction places weights on the right hand side. Weights on the left hand side available as an option.

APPLICATIONS

Halton BRD pressure-relief dampers are used in offshore and marine applications to regulate the pressure in the ductwork system. The Halton pressure relief dampers do not need an actuator or motor. The BRD dampers can be installed in rectangular or circular ducts horizontally or vertically. The damper is in closed position when the pressure in the duct is lower than the adjusted opening pressure. Opening pressure can easily be set by adjusting weight of each damper/installation. Weights are included in the delivery. Pressure relief dampers can be supplied with non-standard dimensions on request.

FEATURES

- Fixed frame in painted, galvanized or stainless steel. Blades of galvanized or stainless steel.
- Models for horizontal or vertical installation
- Blades contain silicone seal to lower the leakage through blades
- Available as ATEX certified
- Leakage class (EN1751:2014) of closed damper up to class 2. Contact Halton for more details.
- Blades linked and open in parallel
- Opening pressure adjusted by changing the position of counterweight(s)
- Minimum opening pressure between 30 Pa and 200 Pa depending on damper size
- Opening pressure can be adjusted up to 300 Pa. For higher opening pressure, contact Halton Marine
- Counterweights included
- Standard construction places weights on the right hand side, weights on the left hand side available as an option
- Final adjustment of counterweights carried out during commissioning onsite
- Maximum duct pressure for damper construction 5000 Pa and maximum air velocity 15 m/s. In case of high duct pressure, contact Halton Marine for finding the most suitable solution.
- Temperature operation range up to +100°C, optionally up to +180°C

GENERAL BRD DRAWINGS

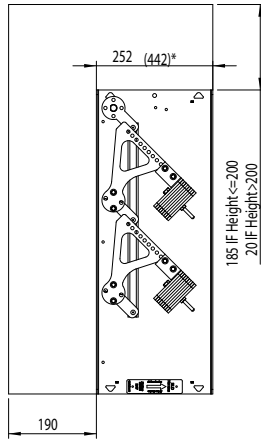

*THIS DIMENSION AS OPTION WHEN ACTUATING MECHANISM NEEDS TO BE INSIDE DAMPER DEPTH

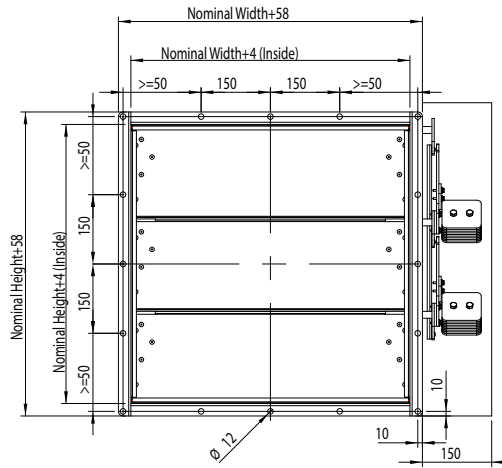

OPERATION AREA

BRD DRAWING, CIRCULAR CONNECTIONS

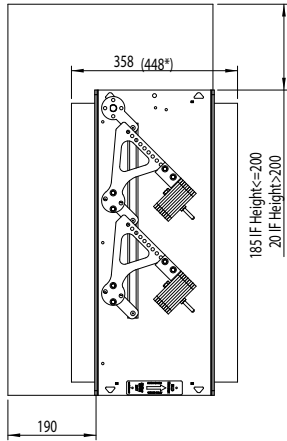

*THIS DIMENSION AS OPTION WHEN ACTUATING MECHANISM NEEDS TO BE INSIDE DAMPER DEPTH

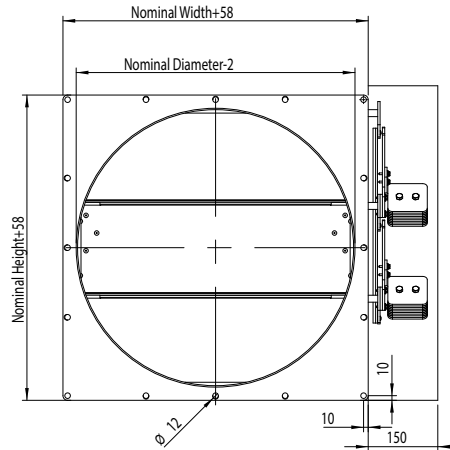

OPERATION AREA

BRD, CIRCULAR, WITH CONNECTION FLANGES

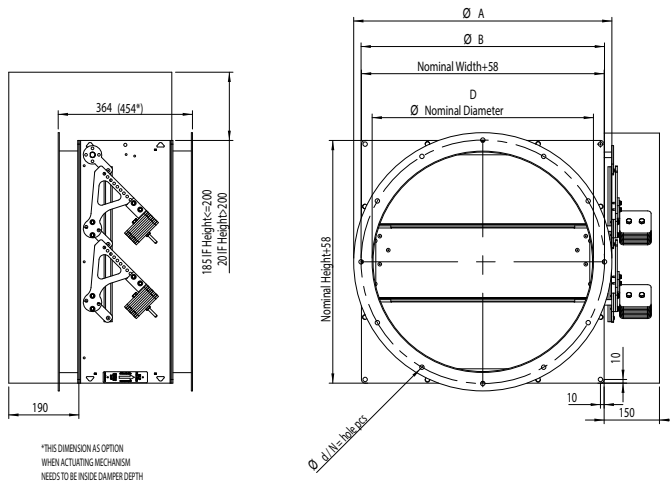

*THIS DIMENSION AS OPTION WHEN ACTUATING MECHANISM NEEDS TO BE INSIDE DAMPER DEPTH

OPERATION AREA

D	B	A	d	N
200	225	300	8,5	4
250	280	350	12	4
315	355	415	12	8
400	450	500	12	8
500	560	600	12	12
630	690	730	12	12
800	860	900	12	16
1000	1070	1100	15	16
1250	1320	1350	15	20

BRD DIMENSIONS AND MATERIAL THICKNESS

BRD pressure relief dampers meet international standards for both rectangular (width B 150-1200 mm and height H 150-1400 mm, 1 mm division) and circular ducts (Ø100 - 1250 mm). Non-standard dimensions are available on request. Standard flange width 27 mm. Flanges and drilling also available according to ISO 15138 standards. Modular construction sizes up to 2400x2800 mm are available. Standard frame material thickness 3 mm. Blades are made of two sheets, each of being 0.8 mm thick (sandwich design).

BRD OPERATION PRINCIPLE

The pressure-relief damper will allow one-way pressure relief in the ductwork. This feature is based on imbalanced blades. When the pressure in the duct rises above a certain value the damper blades begin to open and allow pressure relief. As the pressure increases the blade angle opening increases. The size of the damper, without counterweights, determines the minimum pressure needed (see the table below). The opening force can be adjusted with weights. When the pressure in the ductwork drops below the minimum opening force required, the blades close and seal the duct.

BRD MINIMUM OPENING PRESSURE (WITHOUT COUNTERWEIGHTS)

OPENING DEFINED AS 5 DEGREES BLADE MOVEMENT.

H / HEIGHT (mm)	B / WIDTH (mm)																				
	200	250	300	350	400	450	500	550	600	650	700	750	800	850	900	950	1000	1050	1100	1150	1200
200	100	80	70	65	55	50	50	45	45	40	40	35	35	35	35	35	30	30	30	30	30
250	130	105	90	80	70	65	60	55	50	50	45	45	45	40	40	40	35	35	35	35	35
300	100	85	75	65	60	55	50	50	45	45	40	40	40	35	35	35	35	35	30	30	30
350	85	70	60	55	50	45	45	40	40	40	35	35	35	35	30	30	30	30	30	30	30
400	70	60	55	50	45	40	40	35	35	35	30	30	30	30	30	30	30	30	30	30	30
450	125	105	90	80	70	65	60	55	50	50	45	45	45	40	40	40	40	35	35	35	35
500	110	90	80	70	65	55	55	50	45	45	45	40	40	40	35	35	35	35	35	35	30
550	95	80	70	60	55	50	50	45	45	40	40	40	35	35	35	35	30	30	30	30	30
600	85	70	60	55	50	45	45	40	40	40	35	35	35	35	30	30	30	30	30	30	30
650	120	100	85	75	70	65	60	55	50	50	45	45	45	40	40	40	40	35	35	35	35
700	110	90	80	70	65	60	55	50	50	45	45	40	40	40	35	35	35	35	35	35	30
750	100	85	70	65	60	55	50	45	45	40	40	40	40	35	35	35	35	35	30	30	30
800	90	75	65	60	55	50	45	45	40	40	40	35	35	35	35	30	30	30	30	30	30
850	120	100	85	75	70	60	60	55	50	50	45	45	40	40	40	40	35	35	35	35	35
900	110	90	80	70	65	60	55	50	50	45	45	40	40	40	35	35	35	35	35	35	30
950	100	85	75	65	60	55	50	50	45	45	40	40	40	35	35	35	35	35	30	30	30
1000	95	80	70	60	55	50	50	45	45	40	40	35	35	35	35	30	30	30	30	30	30
1050	120	100	85	75	65	60	55	55	50	50	45	45	40	40	40	40	35	35	35	35	35
1100	110	90	80	70	65	60	55	50	50	45	45	40	40	40	35	35	35	35	35	35	30
1150	105	85	75	65	60	55	50	50	45	45	40	40	40	35	35	35	35	35	30	30	30
1200	100	80	70	65	55	55	50	45	45	40	40	40	35	35	35	35	35	30	30	30	30
1250	115	95	85	75	65	60	55	55	50	50	45	45	40	40	40	35	35	35	35	35	35
1300	110	90	80	70	65	60	55	50	50	45	45	40	40	40	35	35	35	35	35	35	30
1350	105	85	75	65	60	55	50	50	45	45	40	40	40	35	35	35	35	35	35	30	30
1400	100	85	70	65	60	55	50	45	45	40	40	40	35	35	35	35	30	30	30	30	30

WEIGHTS

STANDARD HALTON MARINE BRD DAMPERS (KG) including counter weights. Frame thickness 3mm.

H/HEIGHT (mm)	B / WIDTH (mm)												D2 ØD mm	WEIGHT kg
	150	200	300	400	500	600	700	800	900	1000	1100	1200		
150	8	9	11	13	15	16	18	20	22	24	25	27	100	12
200	10	12	12	14	16	19	20	22	24	26	28	29	160	12
300	12	13	15	18	20	21	24	26	29	31	34	35	200	15
400	14	15	18	20	23	25	28	30	33	36	37	40	250	17
500	17	17	21	24	27	29	32	35	37	40	43	45	315	21
600	19	20	24	26	29	32	36	39	42	45	47	51	400	26
700	21	23	26	30	33	37	40	43	47	50	53	57	500	36
800	22	24	27	33	36	40	43	47	51	54	58	62	630	45
900	26	28	32	36	39	44	48	52	56	60	63	67	800	63
1000	28	30	34	39	43	48	51	55	60	64	68	72	1000	87
1100	31	33	38	42	47	51	56	60	65	70	72	78	1250	116
1200	33	35	40	45	50	54	59	64	69	74	78	84		
1300	36	38	44	48	53	58	64	69	74	79	83	89		
1400	38	40	46	51	56	62	67	73	78	83	88	94		

M02Y2020/Halton Marine reserves the right to alter products without notice.