

HALTON CABEAM

Chilled beam for integrated installation

Integrated above a closet in crew cabins



APPLICATIONS

The Halton CaBeam is a cabin ventilation solution specifically designed for silent cabin comfort with sophisticated air treatment and control. The Halton CaBeam is available as an exposed, recessed or integrated installation.

The integrated CaBeam unit is an active chilled beam solution designed for bulkhead and enclosed installation with return and supply air grilles for demanding marine applications.

The active chilled beam system employs fins to help heat and cool. The system is effective to the point where outdoor air can be mixed with the indoor air without any traditional air conditioning (such as heating, cooling, humidifying, or dehumidifying), allowing the building/ship to meet its "minimum outdoor air" air quality requirements. The active chilled beam system requires much less energy to achieve the same heating and cooling effect as a traditional HVAC system.

The beam acts as a radiator chilled by recirculated water. The warm air rises and is cooled by the chilled beam; once it is cooled, the air falls back to the floor, where the cycle starts over. The ventilation air is delivered to the beam by a central air-handling system via ductwork.

MATERIALS

| PART | MATERIAL | FINISHING |
|-------------------|------------------------------|---|
| Return air grille | Pre-painted galvanised steel | Polyester-epoxy-painted White RAL 9003* 20% gloss |
| Supply air grille | Aluminium | Polyester-epoxy-painted White RAL 9003* 20% gloss |
| Casing | Galvanised steel | |
| Supply air plenum | Galvanised steel | |
| Brackets | Galvanised steel | |
| Coil pipes | Copper | |
| Coil fins | Aluminium | Copper as an option |

*) Special colours available

PLEASE NOTE IMPORTANT - TAILORING

The Halton CaBeam units can be tailored to customer demands according to the needed integration and requirements. Dimensions, capacities, and functionality details can be modified to project-specific. An advanced digital room temperature control completes the solution.

SPECIFICATION

- The supply and return air grilles are openable and removable for maintenance
- The inlet duct connection is modifiable and can be located at the right, left, or middle of the supply-air plenum. When there is an integrated fan, there is no option for a connection in the middle
- The heat exchanger of the beam is oriented such that the water connections can be on either the right or left side of the beam
- All pipes are manufactured from copper, connection pipes with a wall thickness of 0.9–1.0 mm fulfilling the European Standard EN 1057:1996. The fins of the heat exchanger are manufactured from aluminium or copper as an option. The heat exchanger is factory pressure-tested. The maximum operating pressure of chilled/hot water pipework is 1.0 MPa
- The supply air ductwork connection is D125 mm

FEATURES

The cooling philosophy of the beam is based on dry cooling.

Operates as a non-condensing dry system with minimal use of mechanical parts: no mechanical filters, condensation tray, or drainage piping.

Controls and functionality are designed to eliminate the risk of condensation and to provide the highest energy-efficiency possible.

The system can communicate with the operating crew for IEQ, as well as, energy-efficiency and is suitable for network communication (selected parameters).

FUNCTION

The primary supply air enters the plenum of the active chilled beam, from where it is diffused into the room through nozzles and a supply grille on the front side of the beam. The supply air nozzle jets efficiently induce ambient room air through the lower return air grille and the heat exchanger, where it is either cooled or heated. The combined air jet is directed along the ceiling surface. Three different nozzle sizes are available to enable various supply airflow rates. The nozzle plates are interchangeable to account for layout or room change.

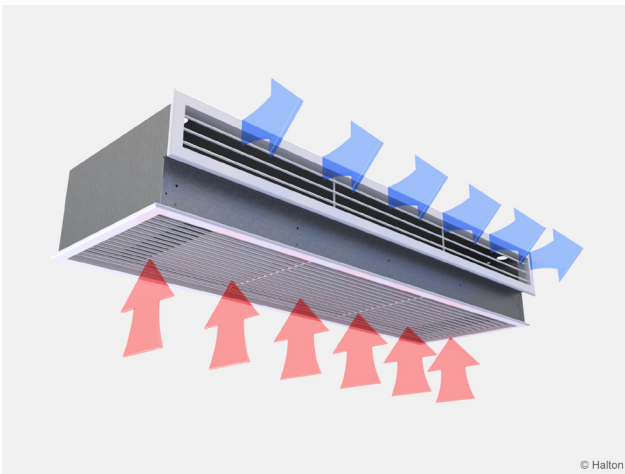

INSTALLATION

Easy installation can be ensured in a prefabricated cabin. The manufacturing method and innovative, compact design allow units to be modified for any situation.



DESIGN CRITERIA

- Room design temperature 24°C / 50% RH
- Fresh air rate 50-75 m³/h
Nozzle pressure 150-200 Pa
- Sensible cooling power 300-1500 W
- Heating power 500-1200 W
- Noise level 25-30 dB(A), boost <35 dB(A)
- Supply and exhaust to design values, 14 dm³/s (50 m³/h)
- Chilled water flow to 0,100 dm³/s (360 dm³/h)
- Chilled water inlet temperature 15°C
- Chilled water outlet temperature 17°C

DIMENSIONS AND WEIGHT

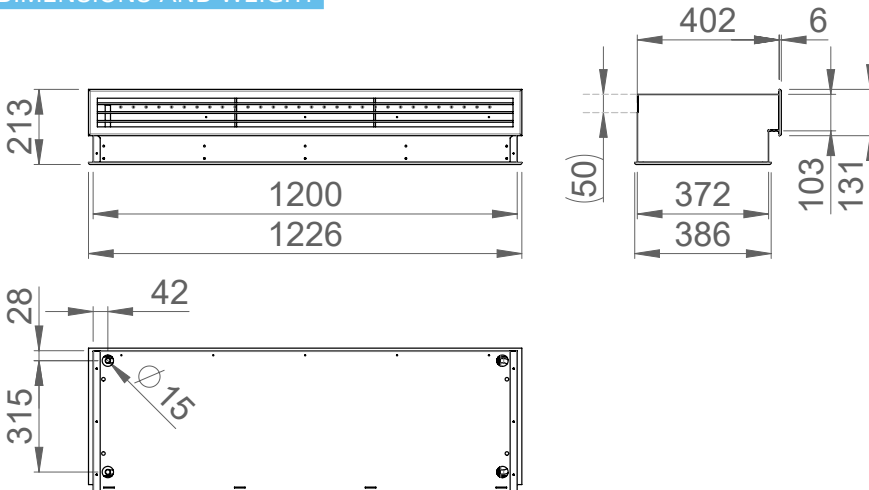

ADJUSTMENT

COOLING

The recommended cooling water mass flow rate is 0.02-0.10 kg/s, resulting in a temperature rise of 1-4°C in the heat exchanger. To avoid condensation, the recommended inlet water temperature of the heat exchanger is over 14-16°C.

HEATING

The heating of the cabin is done by an electric heater in the primary air duct. Heating power in the normal cabin is typically 1-1,2 kW and capillary thermostat with manual reset is in close proximity of heater. Control of heater must be verified because in some cases there has been "leak" in control triac.

HEATING WITH WATER (OPTION)

The recommended heating water mass flow rate is 0.01-0.04 kg/s, resulting in a temperature drop of 5-15°C in the heat exchanger. The recommended temperature of the inlet water for the heat exchanger is 35-40°C.

BALANCING AND CONTROL OF WATER FLOW RATES

Balance the water-flow rates of the chilled beam with the standard control valve by selecting the desired Kvs value in the valve body. When using an automatically balancing combination valve, set the desired water flow rate in the valve body, and verify the pressure difference (min. 16 kPa) across the valve. Regulating the water mass flow rate controls the cooling and heating capacity of the chilled beam.

ADJUSTMENT OF SUPPLY AIRFLOW RATE

Each chilled beam is equipped with a measurement tap for static pressure measurement, which enables fast and accurate measurement of the rate of supply-air flow through the beam. The airflow rate is calculated using the formula.

K value is determined according the table below:

$$q_v = k * \sqrt{\Delta p_m}$$

K value is determined according the table below:

| NOZZLE | WIDTH | k (l/s) | k (m³/h) |
|--------|-------|---------|----------|
| A | 1000 | 2,14 | 7,71 |
| A | 1200 | 2,83 | 10,20 |
| A | 1400 | 3,59 | 12,91 |
| B | 1000 | 2,93 | 10,55 |
| B | 1200 | 3,90 | 14,06 |
| B | 1400 | 4,97 | 17,91 |
| C | 1000 | 4,00 | 14,40 |
| C | 1200 | 5,39 | 19,41 |
| C | 1400 | 6,94 | 24,99 |

SERVICING

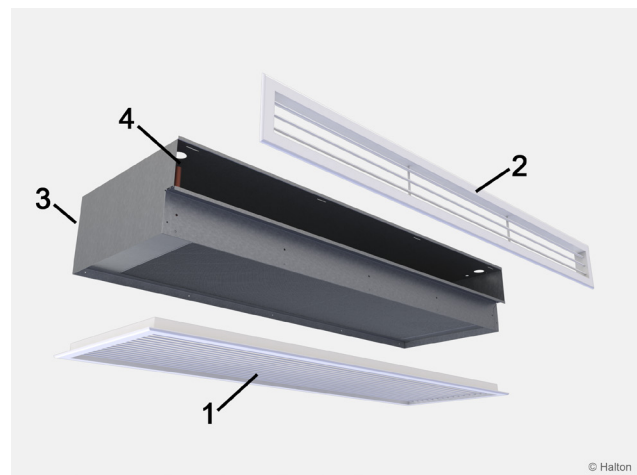

CODE DESCRIPTION

- 1. Return air grille
- 2. Supply air grille
- 3. Supply air connection
- 4. Chilled water pipe connections

Open the return air grille of the chilled beam. Clean the finned coils of the heat exchanger with a vacuum cleaner, taking care not to damage the finned coils. Clean the return and supply air grilles with a damp cloth. Check at regular intervals that the actuators and water-flow control valves are working.

ACCESSORIES

COMMUNICATION ADAPTER

- Bluetooth communication to an external device
- For wireless connection to set cabin unit parameters and troubleshooting NETWORK ADAPTERS
- Network adapter (also available as Wi-Fi) expands a stand-alone unit to network compatible unit (LON or Ethernet networks)
- Enables supervision and advanced energy efficiency functions

CONTROL PANEL FEATURES

- Halton CaBeam systems are available with several different control panel combinations with push buttons, LED bar graphs and LCD-display with or without an integrated key card

COMMON FEATURES

- Balcony door and key card switch available as an option
- Cabin temperature measurement
- Connector for Bluetooth / communication adapter to set cabin parameters
- Software for parameter setting and troubleshooting
- Different colour options and custom labelling available as an option
- Delivered with IC-Cable (interconnection cable)
 - For control panel - control unit connection
 - Prefabricated with plugs on both ends
 - Cable plug on panel side is designed to be pulled through standard installation pipe
 - Halogen-free and flame-retardant
 - Standard length 7 meters

CONTROL PANEL WITH PUSH BUTTONS

- Temperature adjustment by buttons
- Self-diagnose function
- LCD intensity control and auto dimming
- Display for actual and setpoint temperatures available as an option
- Time display available as an option
- A customized background picture available as an option
- Several frame options available



LCD control panel



LCD control panel with push buttons



LCD control panel with push buttons

CONTROL PANEL WITH LCD DISPLAY

- Temperature adjustment by programmable buttons
- Self-diagnose function
- LCD intensity control and auto-dimming
- Display for actual and setpoint temperatures available as an option
- Time display available as an option
- A customized background picture available as an option
- Several frame options available