

FD-CON-2 FIRE DAMPER CONTROL UNIT

For Halton Marine fire dampers



APPLICATIONS

The FD-CON-2 fire damper switch is a control unit for Halton fire dampers. The control unit is installed near the damper in a place where personnel has easy and logical access to it. Two or more FD-CON-2 units can be connected in series. This allows the damper to be locally controlled from both sides of the bulkhead or deck as per SOLAS regulation.

The FD-CON-2 is mainly intended for electrically operated dampers, but it can also be used for pneumatic dampers. In this case the FD-CON-2 unit controls the solenoid valve that controls the supply air to the damper actuator.

FEATURES

- Single or multiple controllers per damper with easy jumper based master/slave configuration
- Protection marking IP67
- Polycarbonate box with M20 cable glands (M25 on request)
 - M20 cable gland, cable diameter Ø 7-13 mm
 - M25 cable gland, cable diameter Ø 10-17 mm
- CE certified product
- Operating range: 18 - 28 VDC 1A, 18 - 253 VAC 50/60Hz 125 mA
- LED lights indicate the damper open and closed positions
- Test switch for indication LED lights

GENERAL FD-CON-2 DRAWINGS

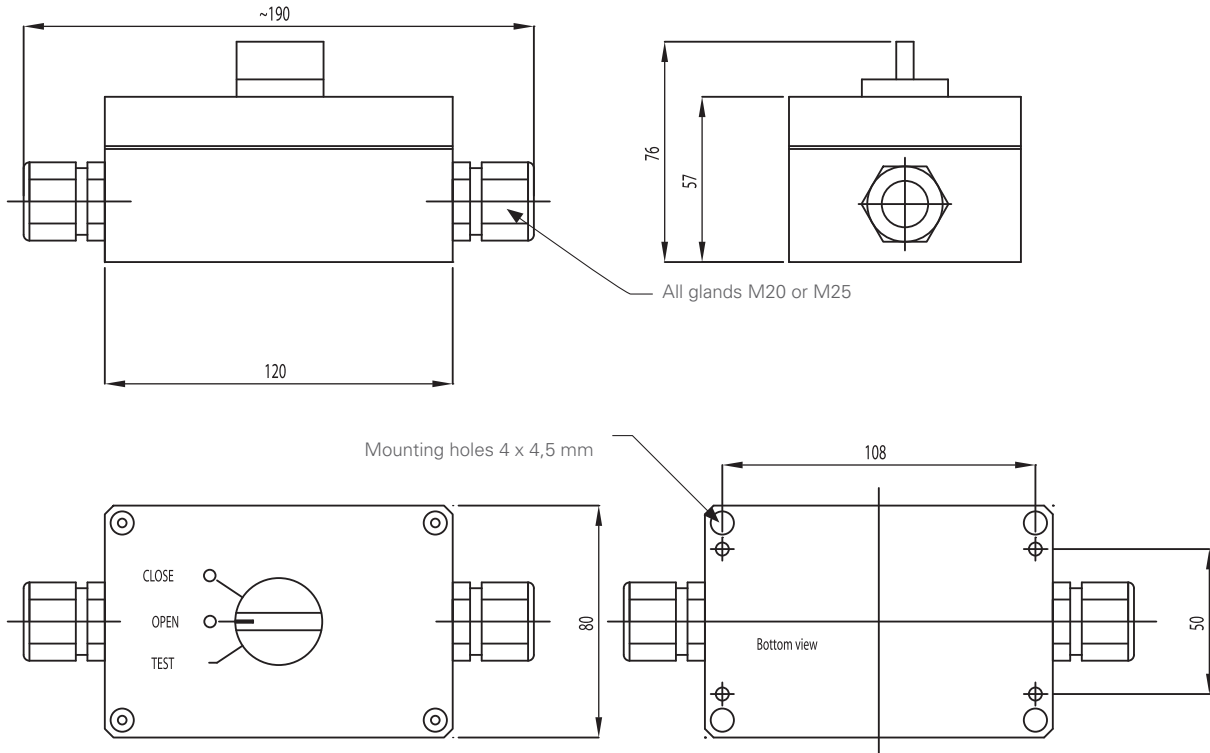

CONTROLLER SETUP, ELECTRICAL DAMPERS

