

## FDA A0(A60) FIRE AND GAS DAMPER

For offshore, marine and navy ventilation systems

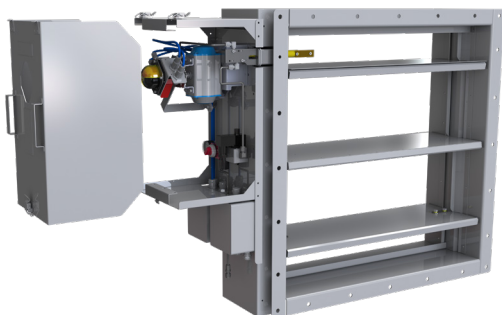

### MATERIALS

PART	MATERIAL	FINISHING
Frame	Carbon steel	Painted or galvanised
Frame	Stainless steel EN 1.4301 (AISI304), EN 1.4404 (AISI316L), EN 1.4432 (AISI316L)	-
Blades	Steel	Galvanized
Blades	Stainless steel EN 1.4301 (AISI304), EN 1.4404 (AISI316L), EN 1.4432 (AISI316L)	-
Maintenance-free bearings	Oil bronze. Stainless steel - EN 1.4404 (AISI316L) available as an option	-
Shafts	Stainless steel EN 1.4404 (AISI316L)	-

### FDA PRODUCT OPTIONS

Halton FDA is available with following actuators:

- FDA-EL: Electrical spring return actuator; standard actuators being 24 VAC/DC or 230 VAC or 120 VAC. Depending of the choice of actuator, the actuator might contain built-in open-closed limit switches. Separate junction box included in the EL-model. A wide range of Ex actuators available, including a one second closing time function as an option.
- FDA-PNR: Pneumatic rotating actuator

HSO: Halton Smart Override function for HVAC damper black-start available for PNR and EL models. With automatic reset function when power and/or pneumatic air supply is reinstated.

A wide range of accessories available.

### APPLICATIONS

Halton FDA fire dampers are type-approved class A0(A60) fire and gas dampers for use in offshore, marine and navy ventilation systems. The FDA can be installed in rectangular or circular ducts. All fire dampers have a fusible link and they prevent the spread of fire and gases within the ventilation ductwork. When the blades are in the open position, the device does not cause significant pressure loss, noise or flow disturbance. An open-closed indicator is visible on the outside of the damper. Fire dampers with non-standard dimensions can be supplied on request.

### FEATURES

- Type-approved by most recognized classification societies: A0 without insulation, A-15 to A-60 when suitably insulated
- Blades contain stainless steel spring seals for low leakage in normal conditions and thermal expansion graphite seals (effective from 150°C) to seal the damper in case of fire. Silicon sealing as an option
- Closed damper fulfills the requirement of leakage class 3 (EN1751:2014) for size > 300x300 mm and for size > 200x200 mm (silicon seals). Casing leakage class C
- The nominal strip fuse release temperature is 50 °C, 74 °C or 100 °C. Other temperatures available
- Nominal glass bulb fuse release is available as an option with temperatures of 68 °C or 93 °C. Other temperatures available
- Low weight due to double skin blade structure
- Electrical or pneumatic operation system available
- Maximum duct pressure for damper construction 5000 Pa and maximum air velocity 15 m/s
- Normal operation temperature for damper between -50 °C to +80 °C. Actuator and component selection can affect this temperature range. Other temperatures available on request
- Available as ATEX certified
- SIL 2 safety assessment certificate available on specific terms

### INSTALLATION

Installation on wall or roof. At wall installation, the blade orientation must always be in a horizontal plane.

GENERAL FDA DRAWINGS

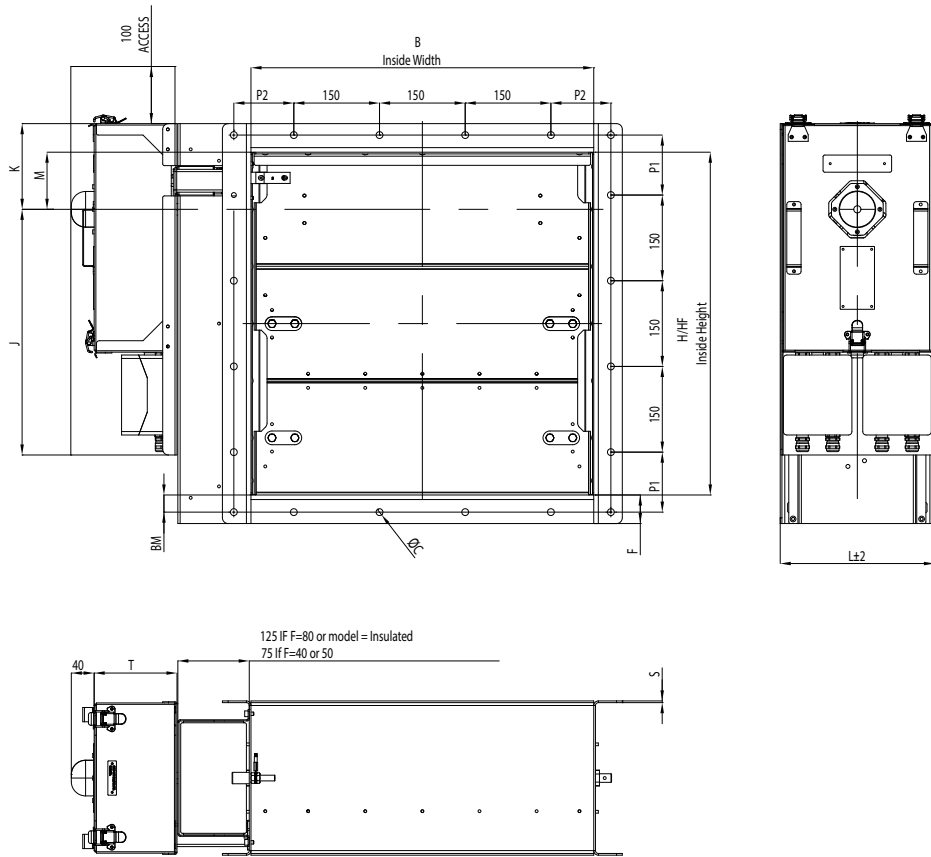

Actuator	J	K	T
AT100	430	150	145
AT100+Halton smart override	510	150	255
AT200	510	150	165
AT200+Halton smart override	510	150	275
AT300	510	180	190
AT300+Halton smart override	510	180	300
Belimo BF	430	150	125
Belimo BF (Damper height<200)	430	90	125
Schischek S	430	150	145
Schischek S (Damper height<200)	430	90	145
Schischek S+Halton smart override	440	220	235
Schischek M	510	150	175
Schischek M+Halton smart override	440	220	165

Material Thickness	Depth
S	L
3	270
4	272
5	275

H Nominal height	HF Free height	M Drive
200	200	100
250	250	125
300	250	125
350	250	125
400	400	100
450	450	125
500	500	125
550	500	125
600	600	100
650	650	125
700	700	125
750	750	125
800	800	100
850	850	125
900	900	125
950	950	125
1000	1000	125
1050	1050	125
1100	1100	125
1150	1150	125
1200	1200	125
1250	1250	125
1300	1300	125
1350	1350	125
1400	1400	125
1450	1450	125
1500	1500	125
1550	1500	125
1600	1500	125

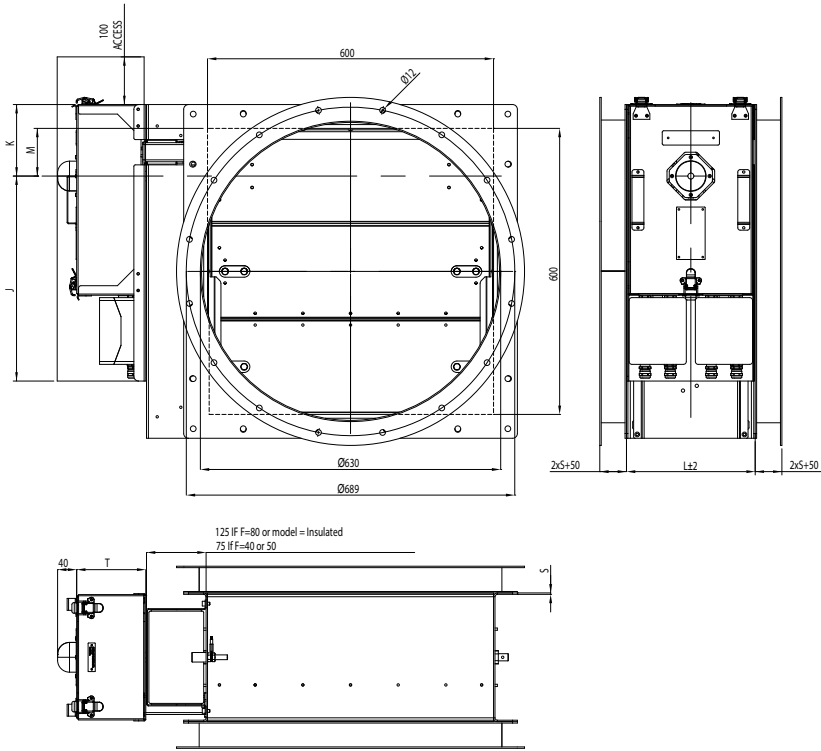

Flange dimensions according to ISO 15138

Nominal Duct Size (Ø D)	Bolt Circle (Ø E)	Bolt hole Size (Ø C)	No. Of Bolts
100	145	10	4
125	170	10	4
150	195	10	4
160	205	10	4
200	245	10	8
250	295	10	8
275	320	10	8
300	345	10	8
315	360	10	8
355	400	10	8
400	459	12	8
450	509	12	12
500	559	12	12
560	619	12	12
600	659	12	16
630	689	12	16
700	759	12	16
710	769	12	16
800	859	12	24
900	959	12	24
1000	1059	12	24
1120	1209	14	24
1200	1289	14	32
1250	1339	14	32
1400	1489	14	32

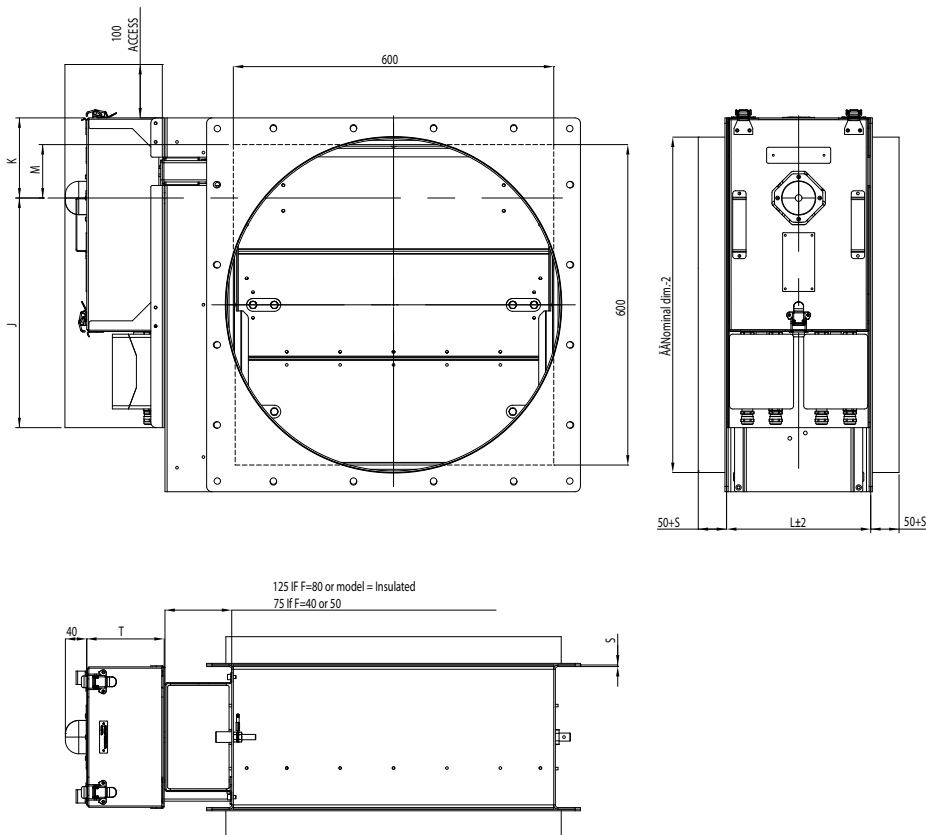

## FDA DIMENSIONS AND MATERIAL THICKNESS

FDA fire dampers meet international standards for both rectangular (width B 200-1200 mm with 25 mm division and height H 200-1600 mm with 50 mm division) and circular ducts (Ø200-1250 mm). Modular constructions up to 2500x2600 mm available.

Non-standard dimensions and flange drilling available on request. Standard flanges and drilling according to ISO 15138 standards. Frame thickness 3 mm or 3-5 mm according to SOLAS. Blades are made of two sheets, each of being 1 mm thick (sandwich design).

### FRAME THICKNESS ACCORDING TO SOLAS

DIMENSIONS	S
If B or H $\geq$ 100 and $\leq$ 449	3
If B or H $\geq$ 450 and $\leq$ 649	4
If B or H $\geq$ 650	5

### EDITION DEC. 2015

DIMENSIONS	S
If A < 0.075 m <sup>2</sup>	3
If A $\geq$ 0.075 and A $\leq$ 0.45 m <sup>2</sup>	4
If A > 0.45 m <sup>2</sup>	5

### FLANGE DIMENSIONS ACCORDING TO ISO 15138

DIMENSIONS	Ø C	F	P1	P2	BM
If longest side $\leq$ 350	10	40	75...150	75...150	20
If longest side 351...1000	12	50	75...150	75...150	30
If longest side $\geq$ 1001	14	80	75...150	75...150	40

### CIRCULAR FLANGE DIMENSIONS ACCORDING TO ISO 15138

DIMENSIONS	Ø C	F
If Ø D $\leq$ 355	10	40
If Ø D 356...1000	12	50
If Ø D $\geq$ 1001	14	80

## OPERATION PRINCIPLE

In the event of a temperature rise in ductwork:

- FDA-EL: fusible link releases and cuts off operating voltage to the spring return motor, allowing the spring to close the damper blades. The fire damper opens automatically when the fuse has been changed and the operating voltage to the motor is re-established.
- FDA-PNR: fusible link releases and cuts off operating pressure to the spring return actuator, allowing springs to close the damper blades. The fire damper opens automatically when the fuse has been changed and the pneumatic air supply is re-established.

**WEIGHTS**

**STANDARD HALTON MARINE FDA DAMPERS (KG) without an actuator.**  
 Frame thickness 3 mm.

H/HEIGHT	B / WIDTH (mm)										
mm	200	300	400	500	600	700	800	900	1000	1100	1200
200	18	20	23	26	29	32	35	38	40	43	46
300	21	24	27	29	32	35	38	41	44	47	49
400	26	29	33	36	39	42	46	49	52	56	59
500	30	33	36	40	43	46	50	53	56	59	63
600	35	39	42	46	50	54	57	61	65	69	72
700	39	42	46	50	54	57	61	65	69	72	76
800	44	48	52	56	60	65	69	73	77	81	86
900	47	52	56	60	64	68	73	77	81	85	89
1000	51	55	60	64	68	72	76	81	85	89	93
1100	56	61	66	70	75	80	84	89	93	98	103
1200	60	65	69	74	79	83	88	93	97	102	106
1300	65	70	75	80	86	91	96	101	106	111	116
1400	69	74	79	84	89	94	99	105	110	115	120
1500	73	78	83	88	93	98	103	108	113	119	124
1600	76	82	87	92	97	102	107	112	117	122	127

Approximate weights without an actuator. Flanges according to ISO 15138.

**STANDARD HALTON MARINE FDA DAMPERS (KG) without an actuator.**  
 Frame thickness according to SOLAS (based on longest duct side).

H/HEIGHT	B / WIDTH (mm)										
mm	200	300	400	500	600	700	800	900	1000	1100	1200
200	18	21	24	31	34	43	48	52	56	60	65
300	21	24	27	35	38	48	52	57	61	65	69
400	26	30	33	42	46	57	62	66	71	76	80
500	34	38	42	46	50	62	67	72	76	81	86
600	40	45	49	54	58	71	76	81	86	92	97
700	50	56	61	66	71	76	81	87	92	97	102
800	57	63	68	74	79	85	91	96	102	107	113
900	62	68	73	79	85	90	96	101	107	113	118
1000	68	73	79	84	90	95	101	107	112	118	123
1100	74	80	86	92	98	104	110	116	122	128	134
1200	79	85	91	97	103	110	116	122	128	134	140
1300	86	92	99	105	112	118	125	131	138	144	151
1400	91	98	104	111	117	124	130	137	143	150	156
1500	96	103	109	116	122	129	135	142	148	155	161
1600	102	108	115	121	128	134	141	147	154	160	166

Approximate weights without an actuator. Flanges according to ISO 15138.

## STANDARD HALTON MARINE FDA DAMPERS (KG) without an actuator.

Frame thickness according to SOLAS Edition Dec. 2015 (based on duct cross-section area).

H/HEIGHT	B / WIDTH (mm)										
mm	200	300	400	500	600	700	800	900	1000	1100	1200
200	18	21	27	31	34	38	41	45	48	52	55
300	21	28	31	35	38	42	45	49	52	56	60
400	30	34	38	42	46	50	54	58	62	66	80
500	34	38	42	46	50	54	58	62	76	81	86
600	40	45	49	54	58	62	76	81	86	92	97
700	45	49	54	58	63	76	81	87	92	97	102
800	51	56	60	65	79	85	91	96	102	107	113
900	55	60	65	70	85	90	96	101	107	113	118
1000	60	65	70	84	90	95	101	107	112	118	123
1100	66	71	76	92	98	104	110	116	122	128	134
1200	70	75	91	97	103	110	116	122	128	134	140
1300	76	82	99	105	112	118	125	131	138	144	151
1400	80	86	104	111	117	124	130	137	143	150	156
1500	85	91	109	116	122	129	135	142	148	155	161
1600	90	108	115	121	128	134	141	147	154	160	166

Approximate weights without an actuator. Flanges according to ISO 15138.

**PNEUMATIC ACTUATORS FOR FDA ACCORDING TO SIZE OF THE DAMPER**

H/HEIGHT mm	B / WIDTH (mm)										
	200	300	400	500	600	700	800	900	1000	1100	1200
200	AT100	AT100	AT100	AT100	AT100	AT100	AT200	AT200	AT200	AT200	AT200
300	AT100	AT100	AT100	AT100	AT100	AT100	AT200	AT200	AT200	AT200	AT200
400	AT100	AT100	AT100	AT100	AT200	AT200	AT200	AT200	AT200	AT200	AT200
500	AT100	AT100	AT100	AT100	AT200	AT200	AT200	AT200	AT200	AT200	AT200
600	AT100	AT100	AT200	AT200	AT200	AT200	AT200	AT200	AT200	AT300	AT300
700	AT100	AT100	AT200	AT200	AT200	AT200	AT200	AT200	AT200	AT300	AT300
800	AT100	AT100	AT200	AT200	AT200	AT200	AT200	AT300	AT300	AT300	AT300
900	AT100	AT100	AT200	AT200	AT200	AT200	AT200	AT300	AT300	AT300	AT300
1000	AT100	AT100	AT200	AT200	AT200	AT200	AT200	AT300	AT300	AT300	AT300
1100	AT100	AT200	AT200	AT200	AT200	AT200	AT300	AT300	AT300	AT300	AT300
1200	AT100	AT200	AT200	AT200	AT200	AT200	AT300	AT300	AT300	AT300	AT300
1300	AT100	AT200	AT200	AT200	AT200	AT300	AT300	AT300	AT300	AT300	AT300
1400	AT100	AT200	AT200	AT200	AT200	AT300	AT300	AT300	AT300	AT300	AT300
1500	AT100	AT200	AT200	AT200	AT200	AT300	AT300	AT300	AT300	AT300	AT300
1600	AT100	AT200	AT200	AT200	AT200	AT300	AT300	AT300	AT300	AT300	AT300

Approximate weights of pneumatic rotary actuator AirTorque. FDA-PNR AT101 as aluminium +1,8 kg, AT104 as stainless steel 4,0 kg, AT201 as aluminium +3,2kg, AT204 as stainless steel +6,4 kg, AT301 as aluminium +6,0 kg, AT304 as stainless steel +13,3 kg. Other actuators available on request.

**ELECTRIC ACTUATORS FOR FDA ACCORDING TO SIZE OF THE DAMPER**

H/HEIGHT mm	B / WIDTH (mm)											
	200	300	400	500	600	700	800	900	1000	1100	1200	
200	Ex/Inmax-15-SF	Ex/Inmax-15-SF	Ex/Inmax-15-SF	Ex/Inmax-15-SF	Ex/Inmax-15-SF	Ex/Inmax-15-SF	Ex/Inmax-15-SF	Ex/Inmax-15-SF	Ex/Inmax-15-SF	Ex/Inmax-30-SF	Ex/Inmax-30-SF	Ex/Inmax-30-SF
300	Ex/Inmax-15-SF	Ex/Inmax-15-SF	Ex/Inmax-15-SF	Ex/Inmax-15-SF	Ex/Inmax-15-SF	Ex/Inmax-15-SF	Ex/Inmax-15-SF	Ex/Inmax-15-SF	Ex/Inmax-15-SF	Ex/Inmax-30-SF	Ex/Inmax-30-SF	Ex/Inmax-30-SF
400	Ex/Inmax-15-SF	Ex/Inmax-15-SF	Ex/Inmax-15-SF	Ex/Inmax-15-SF	Ex/Inmax-15-SF	Ex/Inmax-30-SF	Ex/Inmax-30-SF	Ex/Inmax-30-SF	Ex/Inmax-30-SF	Ex/Inmax-30-SF	Ex/Inmax-30-SF	Ex/Inmax-30-SF
500	Ex/Inmax-15-SF	Ex/Inmax-15-SF	Ex/Inmax-15-SF	Ex/Inmax-15-SF	Ex/Inmax-15-SF	Ex/Inmax-30-SF	Ex/Inmax-30-SF	Ex/Inmax-30-SF	Ex/Inmax-30-SF	Ex/Inmax-30-SF	Ex/Inmax-30-SF	Ex/Inmax-30-SF
600	Ex/Inmax-15-SF	Ex/Inmax-15-SF	Ex/Inmax-15-SF	Ex/Inmax-30-SF	Ex/Inmax-30-SF	Ex/Inmax-30-SF	Ex/Inmax-30-SF	Ex/Inmax-30-SF	Ex/Inmax-30-SF	Ex/Inmax-30-SF	Ex/Inmax-30-SF	Ex/Inmax-30-SF
700	Ex/Inmax-15-SF	Ex/Inmax-15-SF	Ex/Inmax-15-SF	Ex/Inmax-30-SF	Ex/Inmax-30-SF	Ex/Inmax-30-SF	Ex/Inmax-30-SF	Ex/Inmax-30-SF	Ex/Inmax-30-SF	Ex/Inmax-30-SF	Ex/Inmax-30-SF	Ex/Inmax-30-SF
800	Ex/Inmax-15-SF	Ex/Inmax-15-SF	Ex/Inmax-30-SF	Ex/Inmax-30-SF	Ex/Inmax-30-SF	Ex/Inmax-30-SF	Ex/Inmax-30-SF	Ex/Inmax-30-SF	Ex/Inmax-30-SF	Ex/Inmax-30-SF	Ex/Inmax-50-SF	Ex/Inmax-50-SF
900	Ex/Inmax-15-SF	Ex/Inmax-15-SF	Ex/Inmax-30-SF	Ex/Inmax-30-SF	Ex/Inmax-30-SF	Ex/Inmax-30-SF	Ex/Inmax-30-SF	Ex/Inmax-30-SF	Ex/Inmax-30-SF	Ex/Inmax-30-SF	Ex/Inmax-50-SF	Ex/Inmax-50-SF
1000	Ex/Inmax-15-SF	Ex/Inmax-15-SF	Ex/Inmax-30-SF	Ex/Inmax-30-SF	Ex/Inmax-30-SF	Ex/Inmax-30-SF	Ex/Inmax-30-SF	Ex/Inmax-30-SF	Ex/Inmax-30-SF	Ex/Inmax-30-SF	Ex/Inmax-50-SF	Ex/Inmax-50-SF
1100	Ex/Inmax-15-SF	Ex/Inmax-15-SF	Ex/Inmax-30-SF	Ex/Inmax-30-SF	Ex/Inmax-30-SF	Ex/Inmax-30-SF	Ex/Inmax-30-SF	Ex/Inmax-30-SF	Ex/Inmax-50-SF	Ex/Inmax-50-SF	Ex/Inmax-50-SF	Ex/Inmax-50-SF
1200	Ex/Inmax-15-SF	Ex/Inmax-15-SF	Ex/Inmax-30-SF	Ex/Inmax-30-SF	Ex/Inmax-30-SF	Ex/Inmax-30-SF	Ex/Inmax-30-SF	Ex/Inmax-30-SF	Ex/Inmax-50-SF	Ex/Inmax-50-SF	Ex/Inmax-50-SF	Ex/Inmax-50-SF
1300	Ex/Inmax-15-SF	Ex/Inmax-30-SF	Ex/Inmax-30-SF	Ex/Inmax-30-SF	Ex/Inmax-30-SF	Ex/Inmax-30-SF	Ex/Inmax-30-SF	Ex/Inmax-50-SF	Ex/Inmax-50-SF	Ex/Inmax-50-SF	Ex/Inmax-50-SF	Ex/Inmax-50-SF
1400	Ex/Inmax-15-SF	Ex/Inmax-30-SF	Ex/Inmax-30-SF	Ex/Inmax-30-SF	Ex/Inmax-30-SF	Ex/Inmax-30-SF	Ex/Inmax-30-SF	Ex/Inmax-50-SF	Ex/Inmax-50-SF	Ex/Inmax-50-SF	Ex/Inmax-50-SF	Ex/Inmax-50-SF
1500	Ex/Inmax-15-SF	Ex/Inmax-30-SF	Ex/Inmax-30-SF	Ex/Inmax-30-SF	Ex/Inmax-30-SF	Ex/Inmax-30-SF	Ex/Inmax-30-SF	Ex/Inmax-50-SF	Ex/Inmax-50-SF	Ex/Inmax-50-SF	Ex/Inmax-50-SF	Ex/Inmax-50-SF
1600	Ex/Inmax-15-SF	Ex/Inmax-30-SF	Ex/Inmax-30-SF	Ex/Inmax-30-SF	Ex/Inmax-30-SF	Ex/Inmax-30-SF	Ex/Inmax-30-SF	Ex/Inmax-50-SF	Ex/Inmax-50-SF	Ex/Inmax-50-SF	Ex/Inmax-50-SF	Ex/Inmax-50-SF

**Electric rotary actuator Schischek ExMax or InMax.**

Actuator options	Closing time	Material	Weight (appr.)
Ex/InMax-15-SF	3 seconds	Aluminium	3,5 kg
Ex/InMax-15-SF	3 seconds	Stainless steel	7,0 kg
Ex/InMax-15-SF1	1 second	Aluminium	3,5 kg

**Electric rotary actuator Schischek ExMax or InMax.**

Actuator options	Closing time	Material	Weight (appr.)
Ex/InMax-15-SF1	1 second	Stainless steel	7,0 kg
Ex/InMax-30-SF3	3 seconds	Aluminium	9,5 kg
Ex/InMax-50-SF3	3 seconds	Aluminium	9,5 kg

