

HFR/M MULTI-CONNECTION CABIN UNIT

For suites and other larger spaces

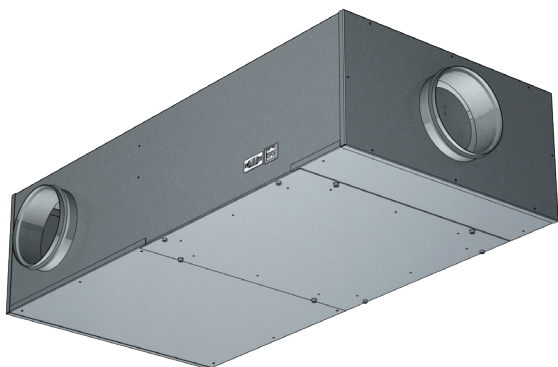

MATERIALS

| PART | MATERIAL | NOTE |
|--------------------------------------|--|--|
| Casing | Hot galvanized steel | Available as an option: stainless steel EN 1.4404 (AISI316L) |
| Spigots | Hot galvanized steel and EPDM rubber | Available as an option: stainless steel EN 1.4404 (AISI316L) |
| Insulation | Mineral wool, s=25 mm, MED approved | - |
| I/O unit | Aluminium / plastic / electronics | - |
| Reheat coil | Stainless steel EN 1.4301 (AISI304) | - |
| Cables | Halogen-free | - |
| Airflow measurement probes and tubes | Aluminium / polyurethane | - |

HFR/M PRODUCT OPTIONS

- Pressure independent model (VAV/CAV)
- Pressure dependent model (VAV)
- Inputs for external switches such as balcony door and key card switches available as an option
- Network compatible with adapter for advanced energy efficiency and supervision system available as an option
- Energy efficiency functions to reduce unnecessary cooling / heating costs available as an option

AVAILABLE REHEATERS

- Standard reheaters: 400W, 800W, 400W+800W, 1200W, 1500W, 1800W
- Offshore reheaters: 400W, 800W, 1200W, 1600W (surface temperature below 90 °C on operating airflow)

Practical power level may be software adjusted cabin by cabin. Cable and power supply design has to be done according to maximum available heating power.

APPLICATIONS

Halton HFR/M is pressure independent or pressure dependent single duct cabin unit with 1-3 outlet connections for terminal units. Pressure independent VAV or CAV operation is facilitated by continuous airflow measurement and damper regulation by intelligent controller. Pressure independent HMF adapts to variations in supply ductwork pressure levels and maintains individual fresh supply airflow rate to each cabin. Pressure dependent VAV operation is facilitated only by damper regulation by intelligent controller. Pressure dependent HMF adapts to room temperature changes by regulating airflow between pre-set minimum and maximum damper positions. Halton HFR/M is an excellent choice for suites, deluxe cabins and office areas where the total airflow needs to be distributed to several points, but controlled centrally with one control panel.

FEATURES

- Pressure range from 200 Pa up to 1000 Pa
- Airflow range 175 m³/h...1000 m³/h
- 230 VAC ±10%, 50/60 Hz
- Inbuilt airflow measurement (pressure independent models)
- Damper min. / max. position settings (pressure dependent models)
- Triac controlled reheating coil(s), adjustable heating power (PWM) 0...100%
- Master/slave functionality: several cabin units can be controlled by one control panel
- Internal fuses included
- All parameters can be set onsite during commissioning by external device or preset at the factory
- All cable connections with fast connectors
- Easily tailored for different types of installations
- 90 °C safety switch with state detection and manual reset
- Minimum flow alarm (pressure independent model) and inbox temperature measurement with overheat limit to cut-off reheater power
- HFR/M cabin unit is supplied with control panel and interconnection cable

GENERAL HFR/M DRAWINGS

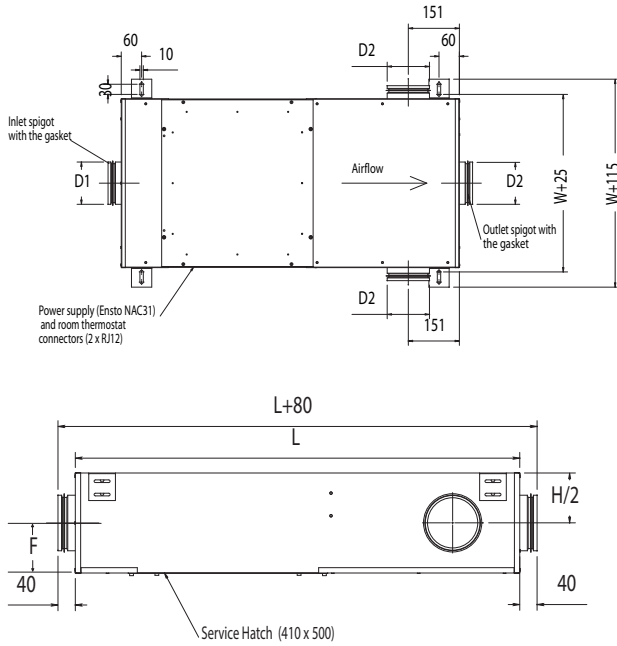

HFR/M DIMENSIONS

| | D1/D2 (DN) | L | W | H | F |
|-----------|------------|------|-----|-----|-----|
| HFR/M-125 | 125 | 1000 | 500 | 225 | 99 |
| HFR/M-160 | 160 | 1000 | 500 | 250 | 121 |
| HFR/M-200 | 200 | 1000 | 500 | 300 | 136 |

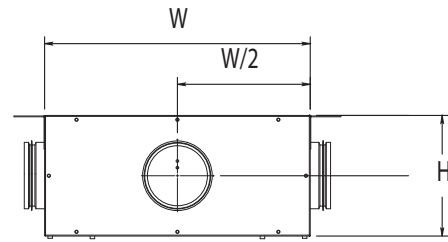

FUNCTION

Control panel includes also a number of special features such as diagnostics function, room brightness measurement and re-programmability. The power supply and data transfer between cabin unit and control panel is carried out via interconnection cable. Temperature range is software adjustable between 10 and 30°C.

FUNCTION OF VAV UNIT

When passenger demands lower temperature by using control panel unit, the damper opens in order to increase the flow of cold air towards the maximum value. When the required temperature in the cabin is achieved, the damper reference is held until the temperature demand changes. In heating mode, the damper restricts the airflow towards its minimum rate, and if the required temperature in the cabin is not thus achieved, the controller activates the electric reheater inside the unit in a stepless manner.

FUNCTION OF CAV UNIT

Airflow is kept in pre-set level in any condition. When passenger demands for a higher temperature by using control panel, the electric reheater inside the cabin unit will be activated in a stepless manner towards to maximum heating capacity or until desired temperature is achieved. When passenger demands for a lower temperature by using control panel, the electric reheater inside the unit will be deactivated in a stepless manner towards to zero heating capacity or until desired temperature is achieved.

REGULATION DIAGRAM, VAV

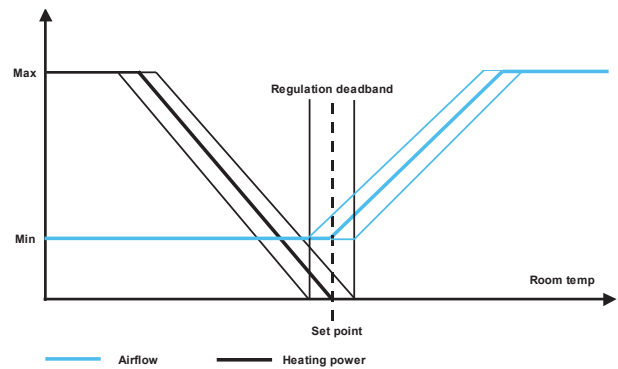

REGULATION DIAGRAM, CAV

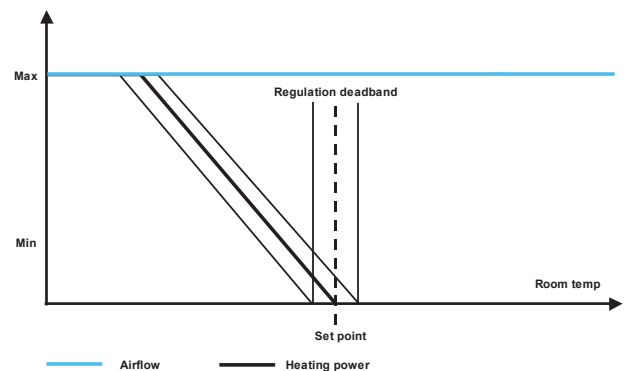

OPERATING RANGE FOR HFR/M

| HFR/M-125 | HFR/M-160 | HFR/M-200 |
|---|---|--|
| 175 m ³ /h - 500 m ³ /h | 250 m ³ /h - 800 m ³ /h | 350 m ³ /h - 1000 m ³ /h |

CABIN UNIT'S AIRFLOW MEASUREMENT ACCURACY

| Accuracy* | AIRFLOW (m ³ /h) | | |
|-----------|-----------------------------|---------|----------|
| | 175-300 | 300-600 | 600-1000 |
| | ±15% | ±10% | ±8% |

* ductwork pressure 200-1000 Pa (optimal)

Note: When comparing airflow measurements between cabin unit and other device, cabin unit's airflow regulation dead-band has to be taken into account (± 10 m³/h).

CONTROL PANEL FEATURES

Halton Marine HFR/M cabin units are available with three different control panel models; with rotating knob, push buttons with LED bar graph (available as option: IP54) and push buttons with LCD-display (available as option: IP54).

COMMON FEATURES

- Cabin temperature measurement
- Connector for bluetooth / communication adapter to set cabin parameters
- Software for parameter setting and trouble shooting
- Different colour options and custom labeling available as an option
- Delivered with IC-Cable (interconnection cable)
 - For control panel - cabin unit connection
 - Prefabricated with plugs on both ends
 - Cable plug on panel side is designed to be pulled through standard installation pipe
 - Halogen free and flame-retardant
 - Standard length 7 meters. Other lengths available.

CONTROL PANEL WITH ROTATING KNOB

- Temperature adjustment by rotating knob

CONTROL PANEL WITH PUSH BUTTONS AND LED BAR GRAPH

- Temperature adjustment by push buttons
- Self diagnose function
- LED intensity control and auto dimming

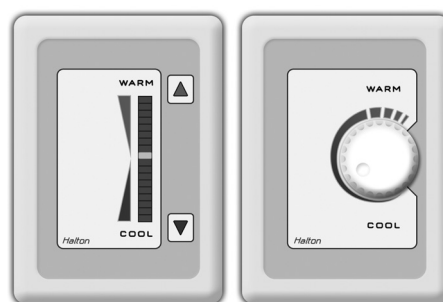

Control panel models; push button and rotating knob



LCD control panel

CONTROL PANEL WITH PUSH BUTTONS AND LCD-DISPLAY

- Temperature adjustment by buttons
- Self diagnose function
- LCD intensity control and auto dimming
- Display for actual and set point temperatures available as an option
- Time display available as an option
- A customized background picture available as an option
- Several frame options available

CABIN VENTILATION CONFIGURATION TABLE

| UNIT | HMM | HMM | HME | HME | HMF | HMF | HMF | HFR/M | HFR/M | HFR/M | HMR | HMR | HML |
|--|--------|----------|--------|----------|---------------|----------|----------|---------------|----------|----------|----------|----------|----------|
| CONTROL PACKAGE | K01 | D03 | K01 | D03 | M00 | M01 | M02 | M00 | M01 | M02 | D21 | H21 | B00 |
| Damper | manual | manual | manual | manual | electric | electric | electric | electric | electric | electric | electric | electric | electric |
| Airflow measurement and control (VAV, CAV) | no | no | no | no | yes | no | yes | yes | no | yes | yes | yes | yes |
| In-box temperature measurement | yes | yes | yes | yes | yes | yes | yes | yes | yes | yes | no | no | yes |
| Reheater safety switch, manual reset | yes | yes | yes | yes | yes | yes | yes | yes | yes | yes | no | no | yes |
| Safety switch state detection | no | yes | no | yes | yes | yes | yes | yes | yes | yes | no | no | yes |
| Spare inputs (balcony door etc.) | no | no | no | no | yes | yes | yes | yes | yes | yes | yes | yes | yes |
| Parameter setting by service tool | no | yes | no | yes | yes | yes | yes | yes | yes | yes | yes | yes | yes |
| CONTROL PANEL | | | | | | | | | | | | | |
| Cabin temperature measurement | yes | yes | yes | yes | yes | yes | yes | yes | yes | yes | yes | yes | yes |
| Controller with push buttons, 18 led bar | no | yes | no | yes | yes | no | no | yes | no | no | yes | no | yes |
| Controller with knob | yes | no | yes | no | no | yes | yes | no | yes | yes | no | yes | no |
| LCD room thermostat | no | optional | no | optional | optional | no | no | optional | no | no | optional | no | optional |
| LED intensity control and auto dimming | no | yes | no | yes | yes | no | no | yes | no | no | yes | no | yes |
| Self diagnose functionality | no | yes | no | yes | yes | no | no | yes | no | no | yes | no | yes |
| Network compatible with adapter | no | yes | no | yes | yes | yes | yes | yes | yes | yes | yes | no | yes |
| CO2 sensor available as an option | no | yes | no | yes | yes | no | no | yes | no | no | yes | no | yes |
| CABLES | | | | | | | | | | | | | |
| Interconnection cable | IC4-X | IC6-X | IC4-X | IC6-X | IC6-X | IC6-X | IC6-X | IC6-X | IC6-X | IC6-X | IC6-X | IC6-X | IC6-X |
| Master-Slave cable | MS4-X | MS2-X | MS4-X | MS2-X | MS2-X (MS5-X) | MS3-X | MS3-X | MS2-X (MS5-X) | MS3-X | MS3-X | MS2-X | MS3-X | MS2-X |

Please note: HMM and HME units are also available without a control package.

MANUALLY CONTROLLED AIRLOWS

Single duct units; HMM, HME

PRESSURE DEPENDENT UNITS

Single duct units; HMF, HFR/M

PRESSURE INDEPENDENT UNITS

Single duct units; HMF, HFR/M, HML

Dual duct units; HMR

ACCESSORIES FOR HFR/M CABIN UNITS

MS-CABLE (MASTER-SLAVE CABLE)

- For master cabin unit - slave cabin unit/units connection
- Prefabricated with plugs on both ends
- Halogen free and flame-retardant
- Standard length is 7 meters. Other lengths available as an option.

COMMUNICATION ADAPTER

- Bluetooth communication to external device
- For wireless connection to set cabin unit parameters and trouble shooting

NETWORK ADAPTERS

- Network adapter (also available as WiFi) expands a stand-alone unit to network compatible unit (LON or Ethernet network)
- Enables supervision and advanced energy efficiency functions
- For more information, see Halton Networks for cabin ventilation -brochure or contact Halton Marine Sales office.

PERFORMANCE DATA

SOUND LEVELS, CABIN SOUND ABSORPTION 4 dB(A)

HFR/M-125

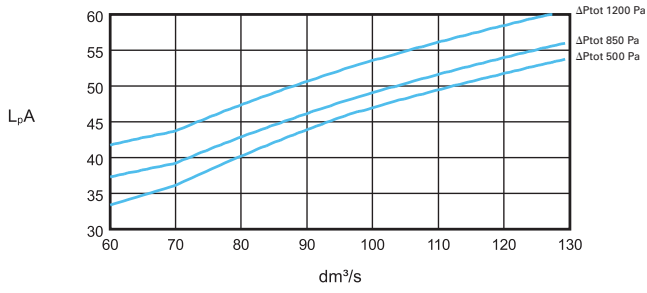

HFR/M-160

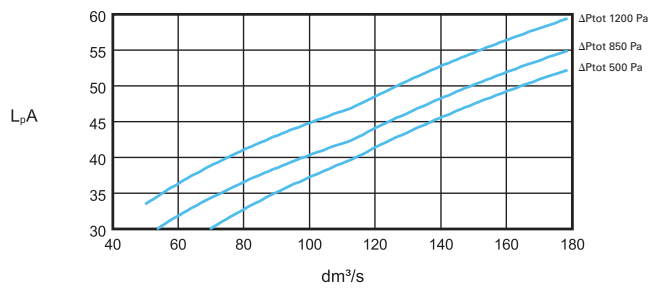

HFR/M-200

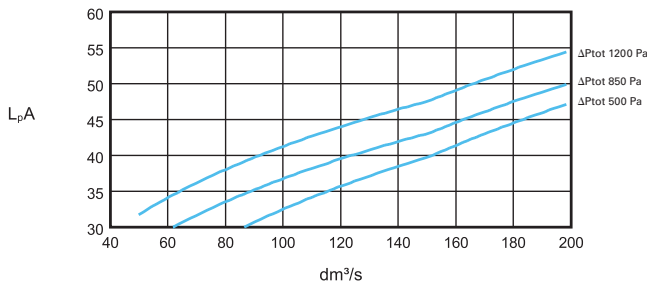

PRESSURE DROP

HFR/M-125

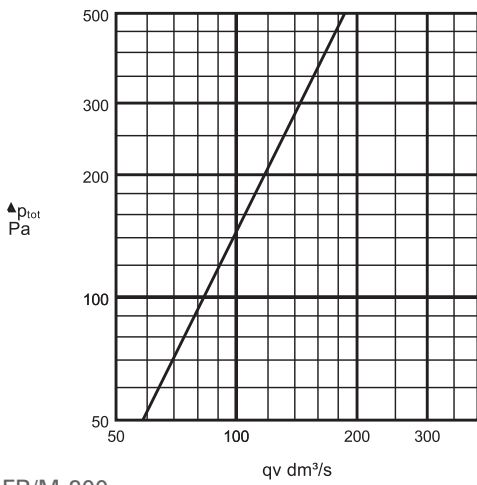

HFR/M-160

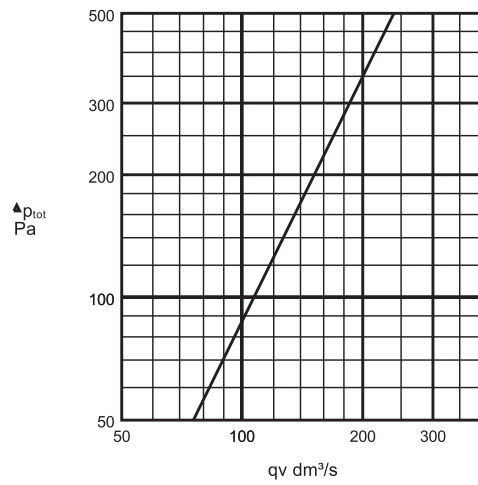

HFR/M-200

