

TCL RECTANGULAR CEILING DIFFUSER

For Halton HMC cabin unit



MATERIALS

PART	MATERIAL	NOTE
Upper plate	Steel	-
Front plate	Steel	-
Front plate fixing screws	Galvanized steel, NOT PAINTED	ISO 7380-1 M5x10
Coupling sleeve	Galvanized steel	Gasket
Duct gasket	Rubber compound	-
Finishing	Epoxy-painted / White RAL 9003	Special colours available on request

DIMENSIONS AND WEIGHT TCL

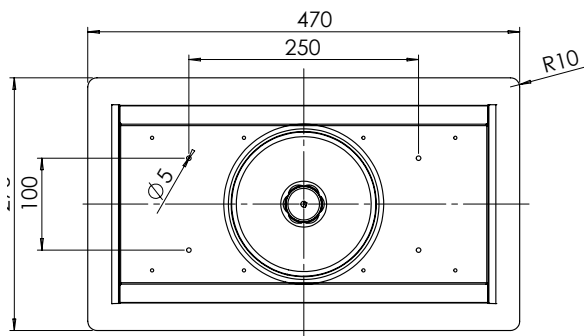
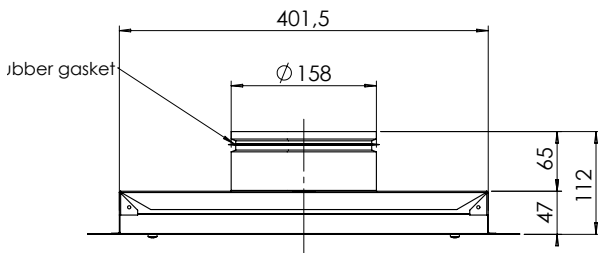

APPLICATIONS

Halton TCL is a rectangular ceiling diffuser for circular duct connection D160 mm. The diffuser is manufactured from steel and finished with epoxy paint in white RAL 9003 as a standard colour. Other colours are available on request. The galvanized steel coupling sleeve is equipped with a rubber gasket compound. The diffuser has a solid front plate. The detachable front plate is fixed to the upper plate with screws; cleaning of the diffuser and cabin unit can be carried out through the diffuser. Halton TCL is especially designed for low smaller spaces and is therefore an excellent choice for crew cabins.

FEATURES

- Horizontal radial air supply, suitable also for exhaust
- Specifically designed to be used in conjunction with HMC cabin unit (applicable for B-0 and B-15 installations)
- Forms an integral impression with a ceiling
- Available for installation directly through one ceiling blade
- Compact and light construction
- Detachable front plate enables cleaning of the diffuser
- Airflow is controlled via an adjusting knob installed through the diffuser
- Circular duct connection with gasket

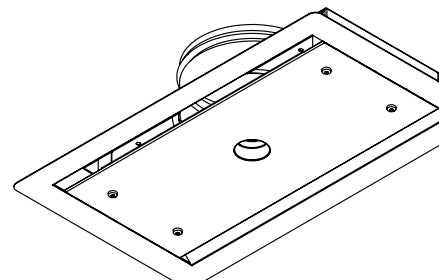
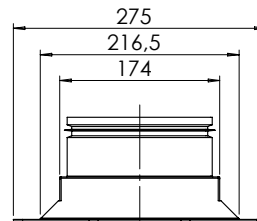

The standard weight of the TCL diffuser is 2,3 kg.

TCL FUNCTION

Air is supplied horizontally into the space through the side slots of the diffuser and induces the room air outside the diffuser. The recommended maximum air temperature difference between supply and room air is 10 °C degrees.



TCL SERVICING

Open the screws of the front panel and clean the parts by wiping with a damp cloth. Put the front panel back into the place and lock the screws.

TCL INSTALLATION

The TCL diffuser can be connected directly to a Halton HMC cabin unit.