

KVE-WW

Capture Jet™ Hood with Water Wash Technology

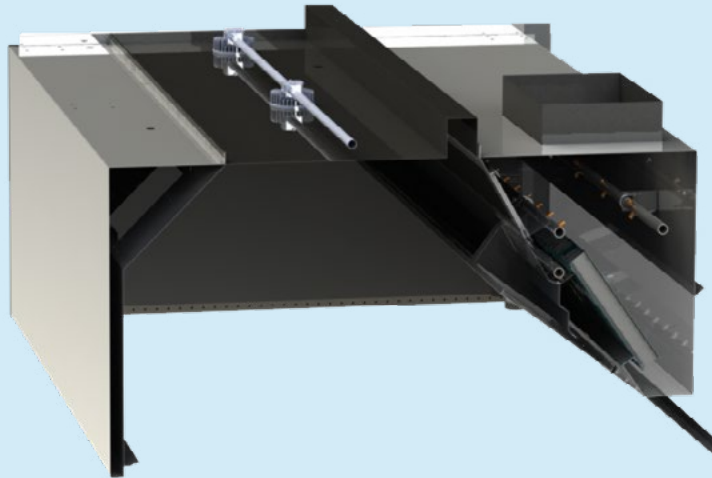

Air quality is becoming a major concern for everyone. Many kitchens will require emissions control in their exhaust systems to comply with growing demands for environmentally-friendly operation.

The Capture Jet™ range of hood systems with Water Wash provides solutions for a variety of commercial food service ventilation applications over virtually any cooking process. Based on Halton's patented highly efficiency Capture Jet™ solution and advanced mechanical KSA filter technology, the hot water wash down is especially suited to facilities with cooking operation producing substantial volumes of grease and requires reduced maintenance.

- Automatic Water Wash features allow for continuous operation without extended shut down for cleaning.
- Improved indoor air quality with reduced energy use. Halton Capture Jet™ with Side-Jet technology reduces the exhaust airflow rates required and improves the capture and containment efficiency of the hood.
- High efficiency grease filtration using UL and NSF classified Halton KSA multi-cyclone filters for removal of up to 95% of particles with a size of 8 microns per ASTM F2519.
- UL Listed Control Panel for water wash cycle.
- T.A.B.™ (testing and balancing) ports, which allow accurate and effective commissioning.
- Standard LED light fixtures.
- Optional LED dimming is available for Capture Jet hoods. Dimming is control by a knob on the switch panel or through Halton HMI Touch Screen.
- Stainless steel, welded design.

NOTE: Factory must be advised of any special requirements of the Authority Having Jurisdiction at time of quote.

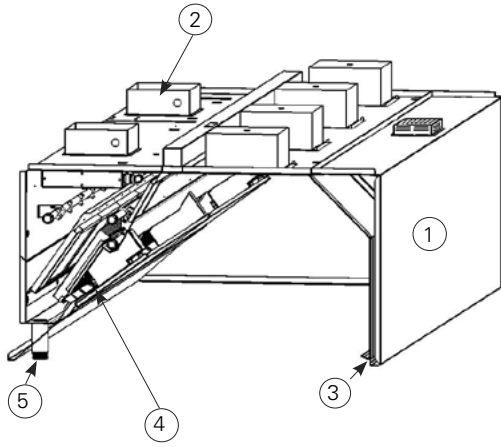

Part	Description
1	18 Ga. stainless steel
2	Exhaust duct collar
3	Capture Jet air
4	KSA grease filter
5	Drain nozzle connection

Construction

The exposed part of the hood is made of stainless steel. The joints of the inner liner have a fully-welded construction. The hood ends have double side wall construction. The Capture Jet™ is introduced through a special discharge panel. Grease and dirt extracted by the KSA multi-cyclone filter. The air flow through the

Capture Jet™ air chamber is determined by the T.A.B. ports located inside the upper hood chamber. The Capture Jet™ system is installed in a plenum, which has been studied in detail using computational fluid dynamics (CFD) to ensure optimum results. The exposed parts are manufactured from 18 ga.

DIMENSIONS

KVE-WW	inches
Length	48....168
Width	48....84
Height	30

QUICK DATA

Length	Recommended Exhaust air volumes	Recommended Capture Jet air volumes
48....168	* Actual exhaust air volumes are calculated by using the heat load based design method utilizing the Halton H.E.L.P. (Hood Engineering Layout Program)	Capture Jet average pressure 0.40" WC (without Side Jet option), 0.20" WC (with Side Jet option).
	*Average operating range from light to heavy duty cooking loads 135 cfm to 275 cfm per linear foot	*Airflows established by a pressure reading *WC= Water Column

*Hoods are ETL or UL listed for USA per UL710, and CANADA per ULC-S646 standards, and NSF certified.

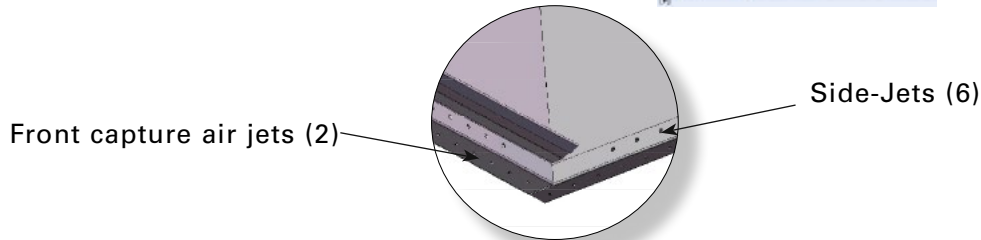
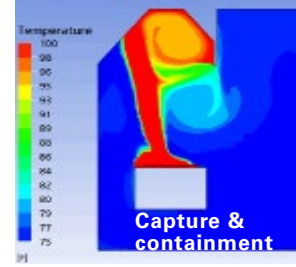
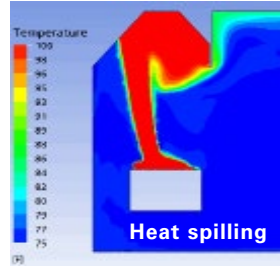
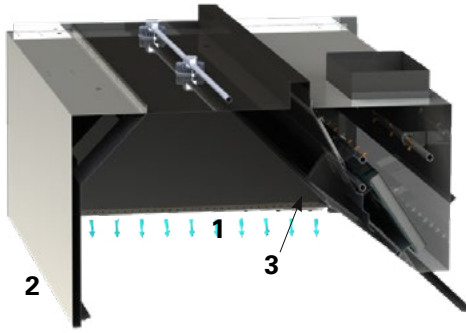

Function

The kitchen hood above cooking appliances contains the rising warm air and contaminants (1).

The capture air jets (2) direct the contaminated air toward the KSA grease filters (3), where grease particles and other impurities are separated from the exhaust air using the cyclone separation principle.

Modifications & Options

- Closure Panels - for canopies below ceiling level
- Backsplash
- Side Skirts
- KFR - Filter Removal Tool
- LED Dimmable Lighting
- Recessed Fluorescent or Incandescent Lighting
- Incandescent Globe Type Lights
- MEP - Master Electrical Panels
- Face or Remote Mounted Switch Panels
- Factory Pre-piped Fire Protection
- Powder Coating in a Variety of Colors
- Custom/Design Stainless Steel Exterior Textures and Finishes
- Listed Exhaust Duct Balancing Damper
- Hood Mounted Fire Cabinet
- M.A.R.V.E.L. Demand Control w/VFD by Halton

Wiring diagram

Supplemental instructions are included in shipment packing, detailing the job specific electrical wiring requirements for the control panel(s) and hood(s). If these cannot be found, please contact the factory prior to any electrical work.

DIMENSIONS

KVE-WW - Wall model	inches
Length	48....168
Width	48....84
Height	30

Noted in drawings as:

- * L = Length
- * W = Width
- * H = Height

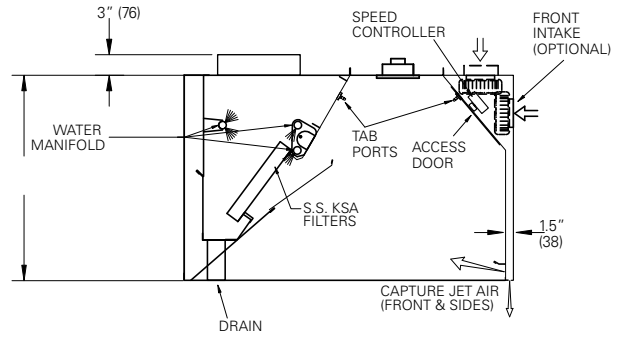

WEIGHTS (LB)

18 ga.

Estimated Crated Shipping Weight	inches	Weight
Width	48"	100 lbs / ft.
Width	54"	110 lbs / ft.
Width	60"	120 lbs / ft.
Width	66"	130 lbs / ft.
Width	72"	140 lbs / ft

*Larger Weights - Consult Factory

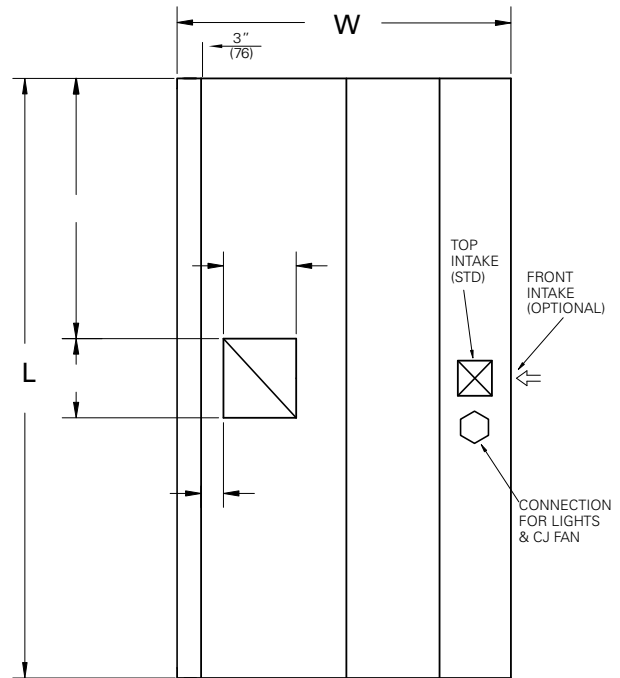

W

Mounting bracket 2" high (52mm)

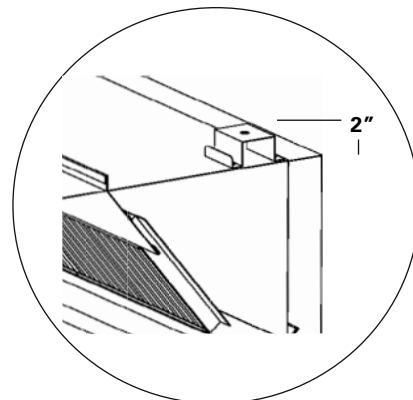

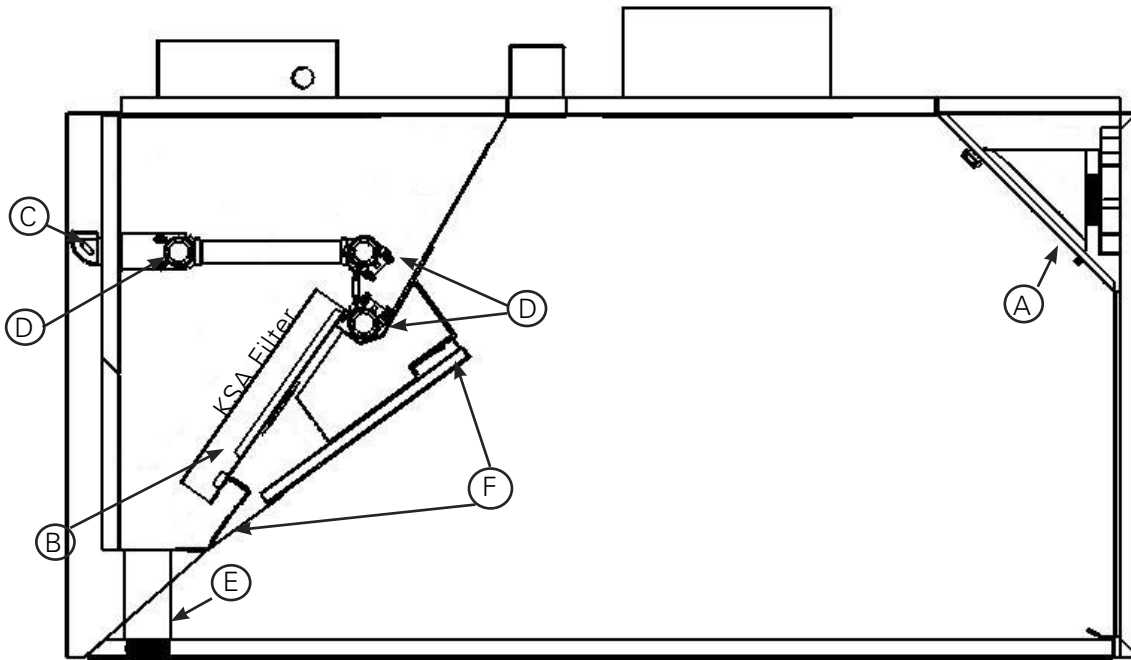

Item	Description
A	Capture Jet Fan Access
B	A Multi-Cyclone KSA Extractor
C	Water Wash Intake Supply
D	Water Wash Nozzle Manifolds
E	Drain Pipe Connection
F	Safety Switches

Suggested specifications

General

Kitchen hoods are constructed from 18 gauge stainless steel. The kitchen hoods shall be supplied complete with outer casing / main body, inner liner, exhaust duct, pressure measurement T.A.B. ports, fluorescent light fixtures, Capture Jet™ air supply nozzles, secondary filter, KSA grease filters, perimeter drain channel and collection cup.

Outer casing panels shall be constructed of stainless steel with a brushed satin finish. Each joint shall be welded and liquid tight, avoiding harmful dripping of condensation.

All exposed welds are ground and polished to the original finish of metal. Canopy ends shall be double sided wall construction (no single wall hoods permitted).

Exhaust

The exhaust airflow will be based on the convective heat generated by the appliances underneath each hood system. Submittals shall include convective heat calculations based on the input power of the appliance served.

Capture Jet™ System

The hood shall be designed with Capture Jet™ with Side-Jet technology to reduce the exhaust airflow rate required, and to improve the capture and containment efficiency of the hood, while reducing energy consumption. The Capture Jet™ air shall be introduced through a special discharge panel and shall not exceed 10% of the calculated exhaust airflow. The Capture Jet™ discharge velocity will be a minimum of 1500 feet per minute. Slot or grille type discharge shall not be used. The Capture Jet™ shall be internally mounted with a speed control and will not require a fire damper or electronic shut down in fire mode.

T.A.B. Ports

The airflows through the extractors and the Capture Jet™ air chamber are to be determined through the integral T.A.B. (Testing and Balancing) ports mounted in the hood. The airflows are to be determined by the pressure vs. airflow curves supplied by Halton.

Grease Filters

The hood shall be equipped with KSA multi-cyclone stainless steel grease extractors. The KSA filters shall be NSF and UL classified. The grease extraction efficiency is 93% on particles with a diameter of 5 microns and 98% on particles with a diameter of 15 microns or larger as tested by an independent testing laboratory. The pressure loss over the extractor shall not exceed 0.50" of w.c at flow rates approved by U.L. for heavy load cooking. Sound levels shall not exceed an NC rating of 55. Baffle or slot type extractors shall not be used.

Light Fixtures

Hood lights shall be U.L. Listed LED fixtures, suitable for grease hoods. 20 Watts per fixture, 50 foot candles at cooking surface. Option: Recessed fluorescent, recessed incandescent or incandescent globe type lighting. The lighting shall be suitable for single phase power supply. Dimmable LED option is available. Standalone Hood based dimming control on the switch panel. When M.A.R.V.E.L. controls are used, all hoods connected to the system can have the light intensity adjusted through the HMI touch screen simultaneously.

Control Panel

The master electrical panel consisting of one starter per motor with overload protection will be supplied. Control panel to hood or remote mounted. (For constant volume systems). M.A.R.V.E.L. controlled systems come with an HMI touch screen to monitor variable volume operation and incorporate the use of V.F.D.'s to control fan operation.

Fire Suppression System

The kitchen hood fire extinguishing system shall protect the kitchen hood against grease fires by a completely automatic fire control system, which consists of wet chemical. The fire detection system shall be capable of detecting fire in the hood, duct, or surface equipment and shall automatically discharge liquid extinguishing agent into the plenum chamber, exhaust duct collar, and cooking appliance areas to ensure against re-ignition or re-flash. System components shall include a spring-loaded fusible link detector, wall mounted emergency pull stations, wall mounted automan and cabinet, and a mechanical gas valve installed in the gas line serving the cooking equipment. System installation shall be made by an authorized representative of the system manufacturer and conform to U.L. 300 requirements and local codes.

Motor Starter

Motor starter with overload protection will be provided for each fan motor supplied by Halton.

Water Wash

The hood shall include three full length wash manifolds equipped with brass spray nozzles. When the wash cycle is initiated, the exhaust fan shall shut off. The wash sprays shall come on for the length of time programmed in the control panel. The upper manifold shall wash the plenum removing the daily accumulation of grease particulate. The two forward manifolds shall wash the interior and exterior of the grease extractor. All controls and components for operation of the water Wash system shall be housed in the Ventilator Control Cabinet.

The company has a policy of continuous product development, therefore we reserve the right to modify design and specifications without notice.

For more information, please contact your nearest Halton agency. To find it: www.halton.com