

KVW-UV

Capture Jet™ Hood with UV Technology



Air quality is becoming a major concern for everyone. Many kitchens will require emissions control in their exhaust systems to comply with growing demands for environmentally-friendly operation.

The Capture Jet™ range of hood systems with Capture Ray™ technology provides solutions for a variety of commercial food service ventilation applications over virtually any cooking process. Based on Halton's patented highly efficiency Capture Jet™ solution and advanced mechanical KSA filter technology, the Capture Ray™ feature with scheduled maintenance keeps the plenum and duct virtually grease-free and mitigates the cooking odor and emissions.

- Integrated Capture Ray™ Ultraviolet cassette(s) with complete controls and safety features.
- Highly efficient Capture Jet™ technology reduces the exhaust airflow volume required.
- Heat load design method.
- ASTM 1704 validated performance.
- Easy access to UV cassettes for maintenance.
- Stainless steel Model KSA 'Multi cyclone' high efficiency grease filters - UL and NSF classified.
- T.A.B.™ (testing and balancing) ports, which allow accurate and effective commissioning.
- UL listed Control Panel for UV operation.
- Stainless steel welded construction.
- Halton HCL Culinary Lights provide the best visual comfort while contributing to improved safety and energy savings.
- Optional LED lights and LED dimming is available for Capture Jet hoods. Dimming is control by a knob on the switch panel or through Halton HMI Touch Screen.
- Stainless steel, welded design.

NOTE: Factory must be advised of any special requirements of the Authority Having Jurisdiction at time of quote.

KVW-UV

Capture Jet™ Island Hood with UV Technology

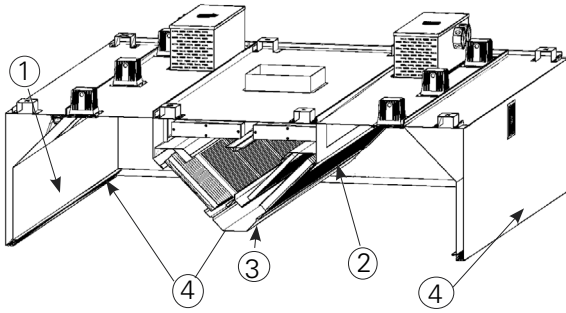

Construction

The exposed part of the hood is made of stainless steel. The joints of the inner liner have a fully-welded construction. The hood ends have double side wall construction. The Capture Jet® is introduced through a special discharge panel (1). Grease and dirt extracted by the KSA multi-cyclone filter (2) can be removed from the hood by emptying the collection tray (3). The air flow through the Capture Jet® air chamber is determined by the T.A.B. ports located inside the upper hood chamber(4). The Capture Ray™ system is installed

in a plenum, which has been studied in detail using computational fluid dynamics (CFD) to ensure optimum results.

The Capture Ray™ control panel is designed to operate the UV lamps only under safe conditions and to give a warning in the case of lamp failure, fan failure, other operational failure or expiration of lamp lifetime. Lifetime of one UV lamp is up to 10,000h, if system is maintained as per Halton's Operation & Maintenance manual. The exposed parts are manufactured from 18 ga.

DIMENSIONS

KVW-UV	inches
Length	48....168
Width	60....84
Height	24....30

QUICK DATA

Length	Recommended Exhaust air volumes	Recommended Capture Jet air volumes
48....168	* Actual exhaust air volumes are calculated by using the heat load based design method utilizing the Halton H.E.L.P. (Hood Engineering Layout Program)	Capture Jet average pressure 0.40" WC (without Side Jet option), 0.20" WC (with Side Jet option).
	*Average operating range from light to heavy duty cooking loads 180 cfm to 400 cfm per linear foot	*Airflows established by a pressure reading *WC= Water Column

*Hoods are ETL or UL listed for USA per UL710, and CANADA per ULC-S646 standards, and NSF certified.

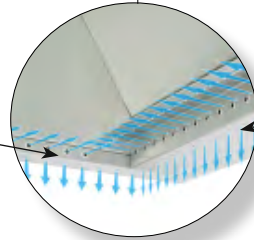
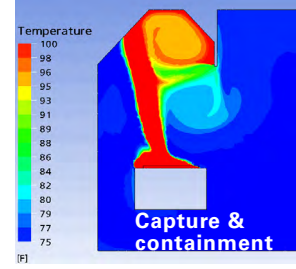
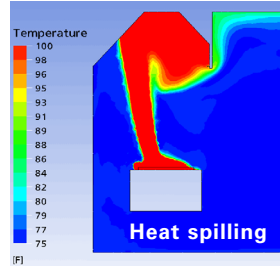
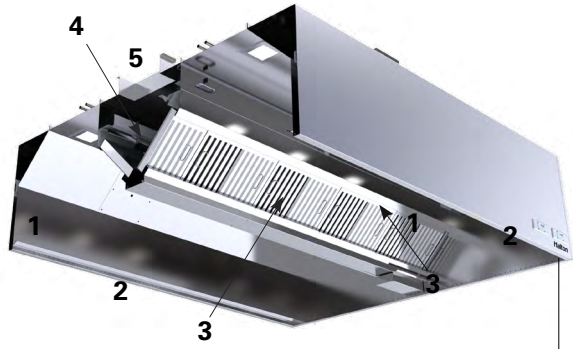

Front capture air jets (2)

Side-Jets

Function

The kitchen hood above cooking appliances collects the warm air and contaminants (1).

The Capture Jets (2) direct the contaminated air toward the KSA grease filters (3), where grease particles and other impurities are separated from the exhaust air using the cyclone separation principle. Behind these and inside the hood are a series of ultraviolet lamps (4).

The grease vapor and effluents that are not collected by high-efficiency filters pass over the lamps. This causes a chemical reaction that destroys the grease and converts it into carbon dioxide and water vapor. The chemical action carries over into the duct (5) and helps keep the duct and exhaust fan clean.

Modifications & Options

- Closure Panels - for canopies below ceiling level
- Backsplash
- Side Skirts
- KFR - Filter Removal Tool
- Optional LED Lights or LED Dimmable Lighting
- Recessed Fluorescent or Incandescent Lighting
- Incandescent Globe Type Lights
- MEP - Master Electrical Panels
- Face or Remote Mounted Switch Panels
- Factory Pre-piped Fire Protection
- Powder Coating in a Variety of Colors
- Custom/Design Stainless Steel Exterior Textures and Finishes
- Automated Balancing Damper option with M.A.R.V.E.L. II demand controls
- Hood Mounted Fire Cabinet
- M.A.R.V.E.L. Demand Control w/VFD by Halton

Wiring diagram

Supplemental instructions are included in shipment packing, detailing the job specific electrical wiring requirements for the control panel(s) and hood(s). If these cannot be found, please contact the factory prior to any electrical work.

DIMENSIONS

KVE-UV - Wall model	inches
Length	48....168
Width	60....84
Height	24....30

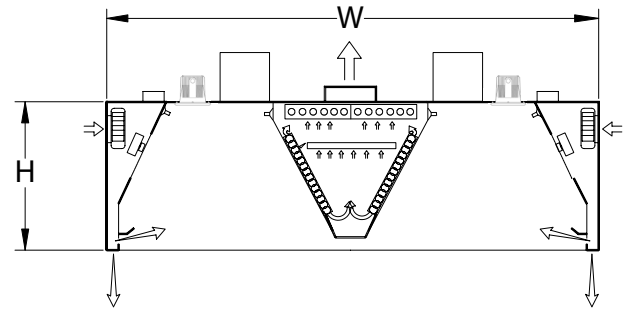

Noted in drawings as:

- * L = Length
- * W = Width
- * H = Height

WEIGHTS (LB)

18 ga.

Estimated Crated Shipping Weight	inches	Weight
Width	60"	120 lbs / ft.
Width	72"	130 lbs / ft.
Width	84"	140 lbs / ft.

*Larger Weights - Consult Factory

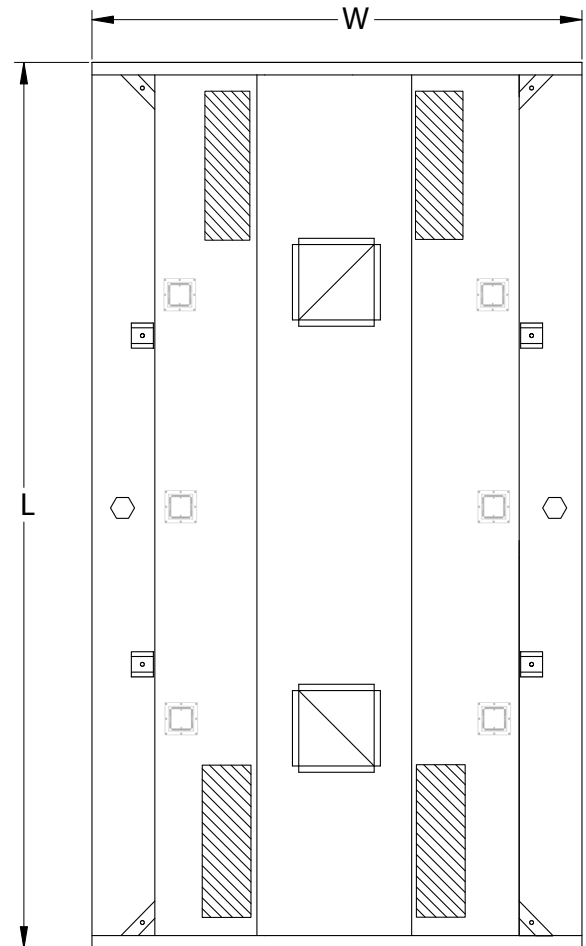

Mounting bracket 2" high (52mm)

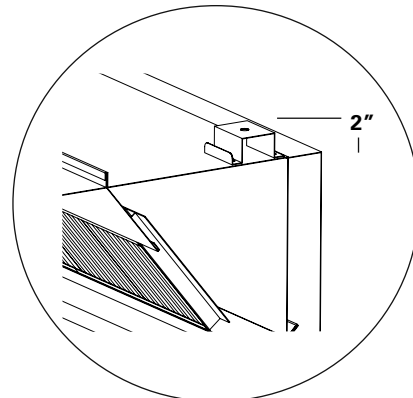

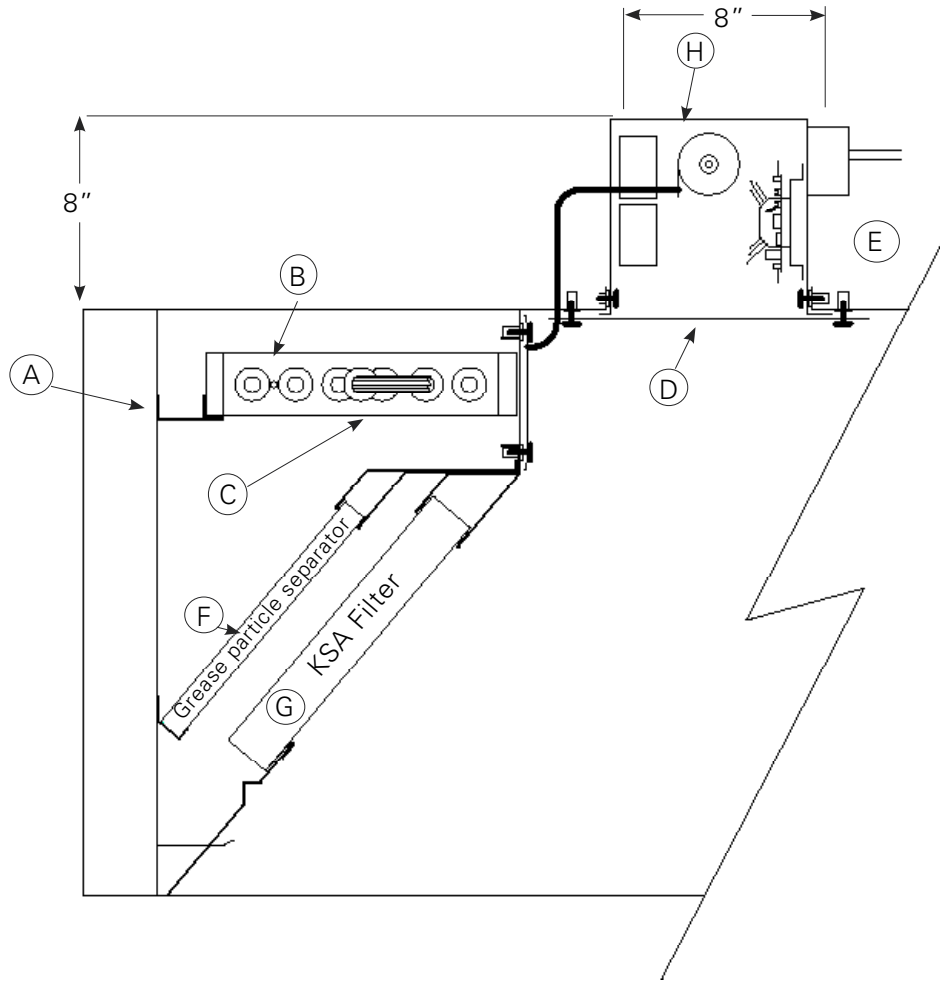

Item	Description
A	Cassette Access Panel - for easy access and removal of UV cassette(s)
B	UV Cassette - contains multiple UV bulbs (Handle with care)
C	Amphenol Connector - Military spec fitting for electrical connection in plenum
D	Ballast Box Access Panel - for access to components shown (see illustration)
E	Sensory Board - Circuit board that senses a fault in voltage to the bulbs
F	Stainless steel grease particle separator
G	Primary Filter - A multi-cyclone KSA filter
H	Ballast Box- located on the top of the hood for control of the UV cassette(s)

Balancing of Capture Jet™ with UV Technology Hoods

The capture jet and exhaust air flows are easily and accurately determined by measuring the pressure difference from the T.A.B. ports mounted in each plenum. Corresponding air flows can be read from the diagrams provided.

All T.A.B. readings assume cold conditions. To adjust for an exhaust temperature of 110°F, multiply the readings by a factor of 0.93.

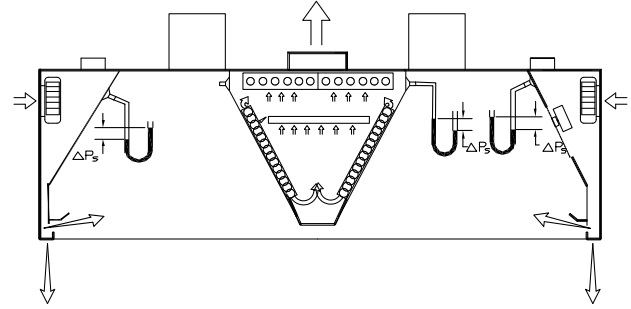

Exhaust air flow vs. pressure differential

KVW-UV - 2 Filters

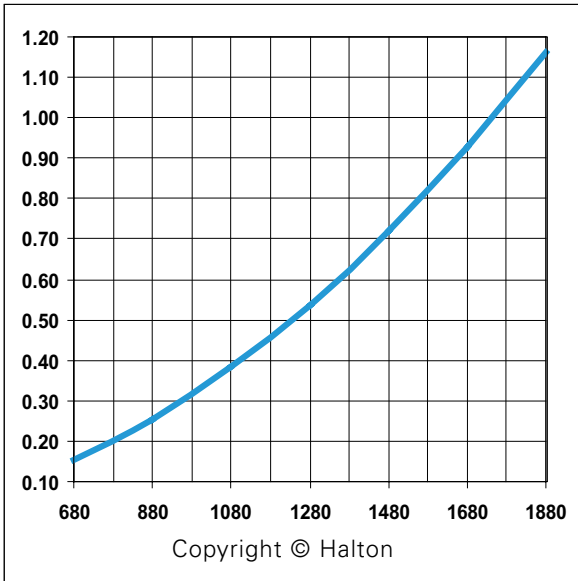

KVW-UV - 2.5 Filters

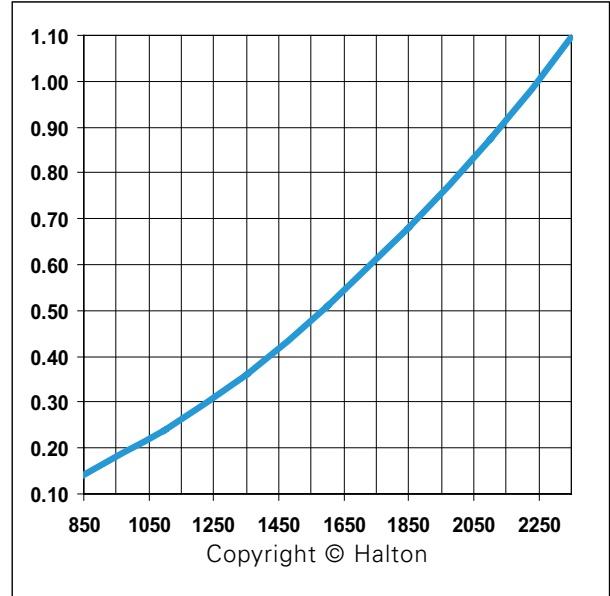

KVW-UV - 3 Filters

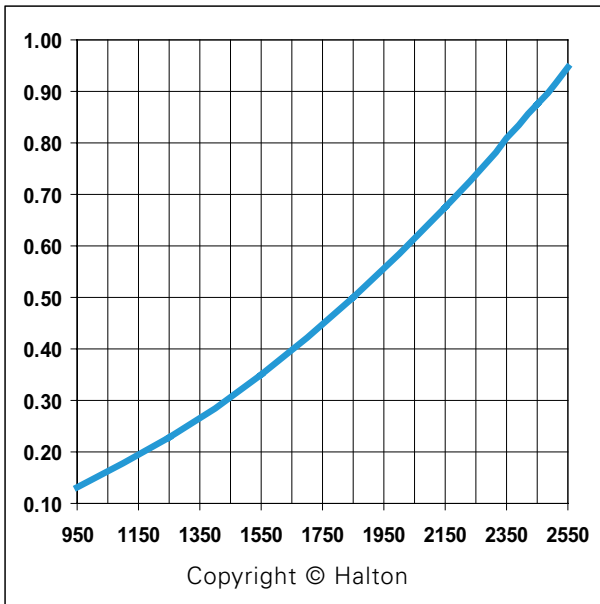

KVW-UV - 3.5 Filters

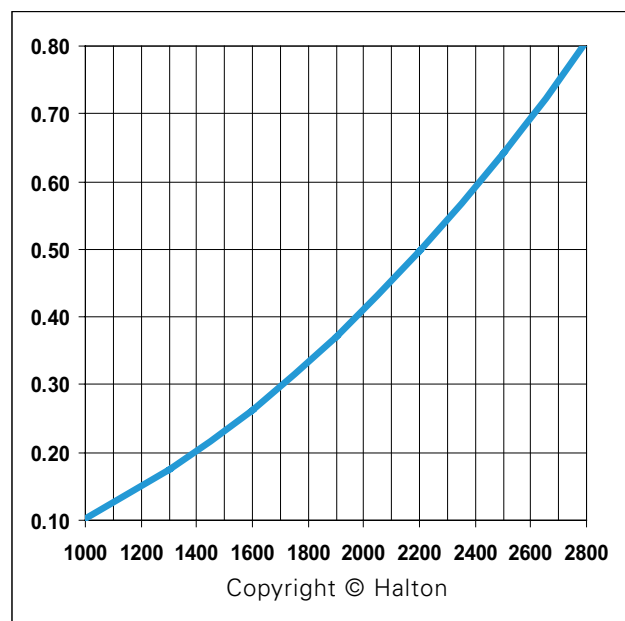

KVW-UV - 4 Filters

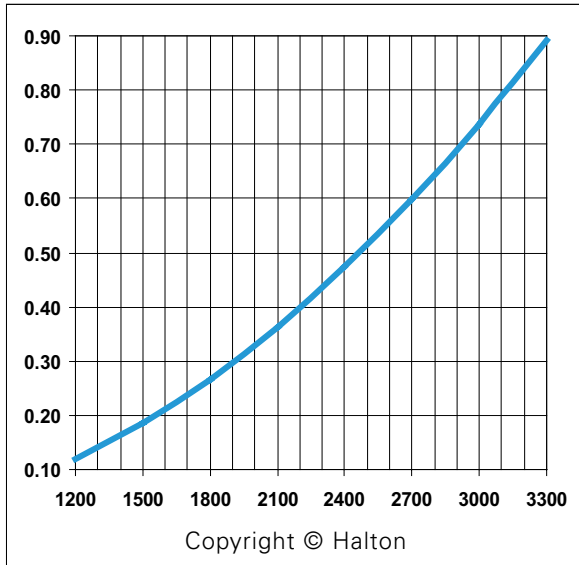

KVW-UV - 4.5 Filters

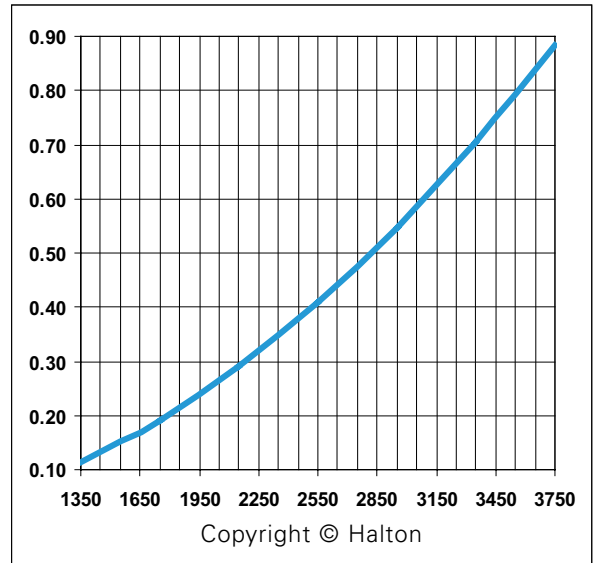

KVW-UV - 5 Filters

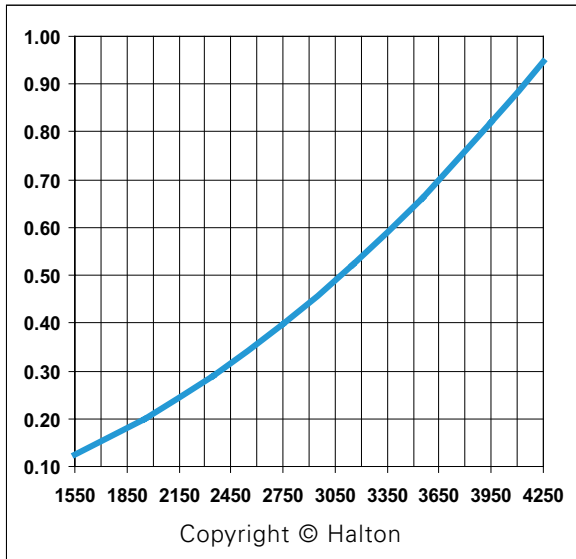

KVW-UV - 5.5 Filters

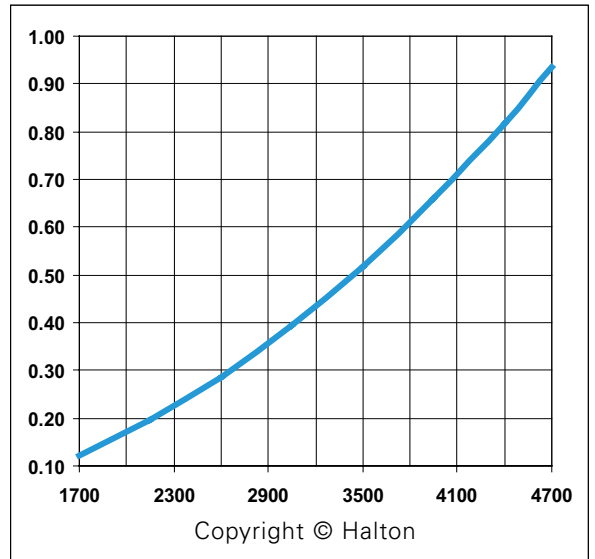

KVW-UV - 6 Filters

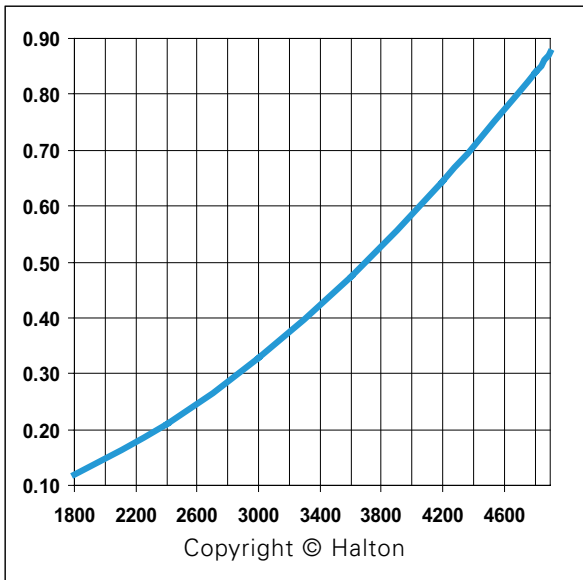

KVW-UV - 6.5 Filters

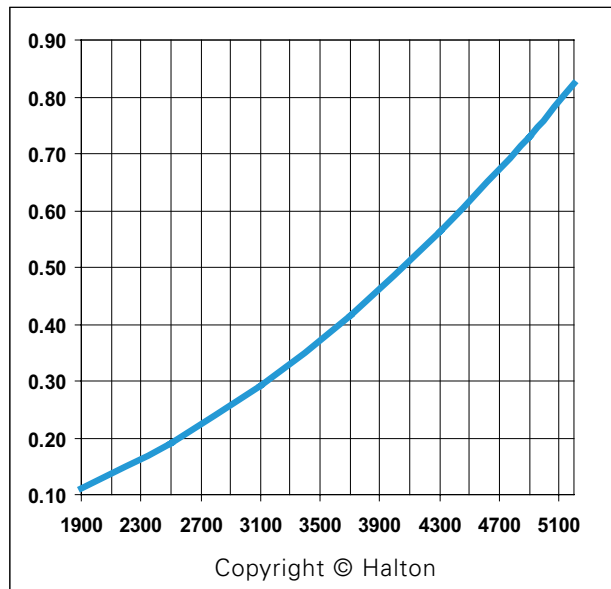

KVW-UV - 7 Filters

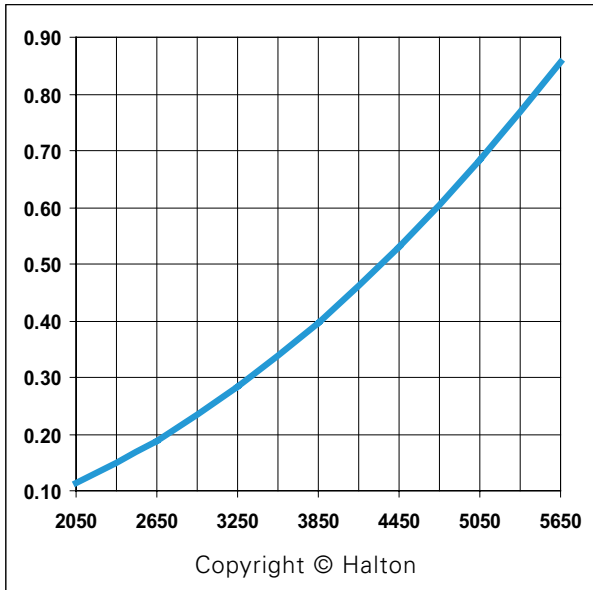

KVW-UV - 7.5 Filters

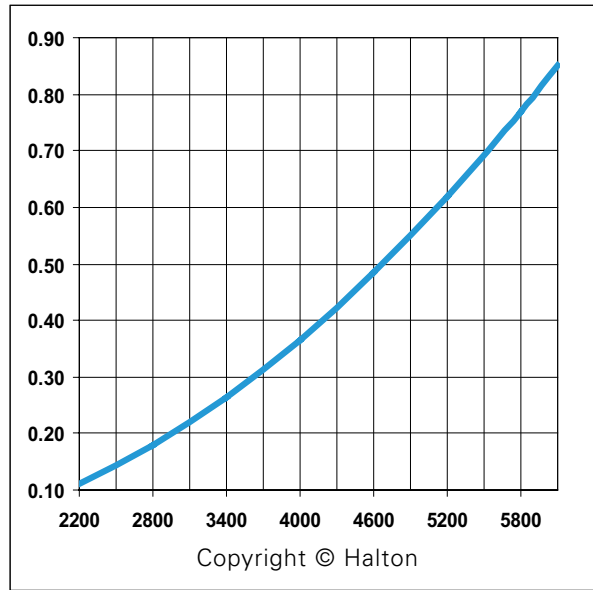

KVW-UV - 8 Filters

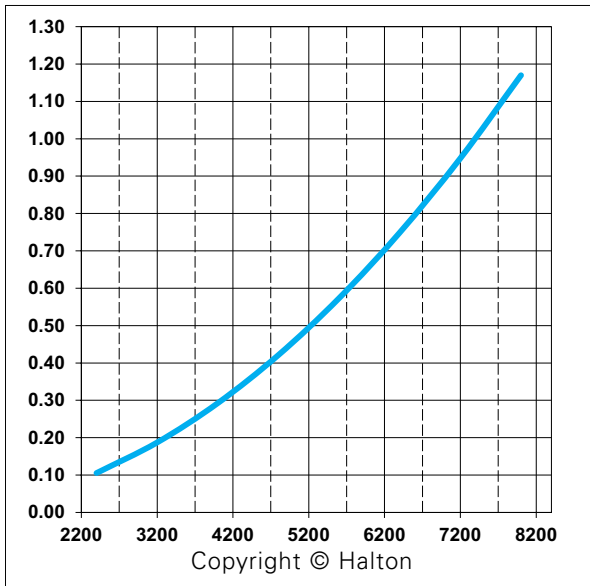

KVW-UV - 8.5 Filters

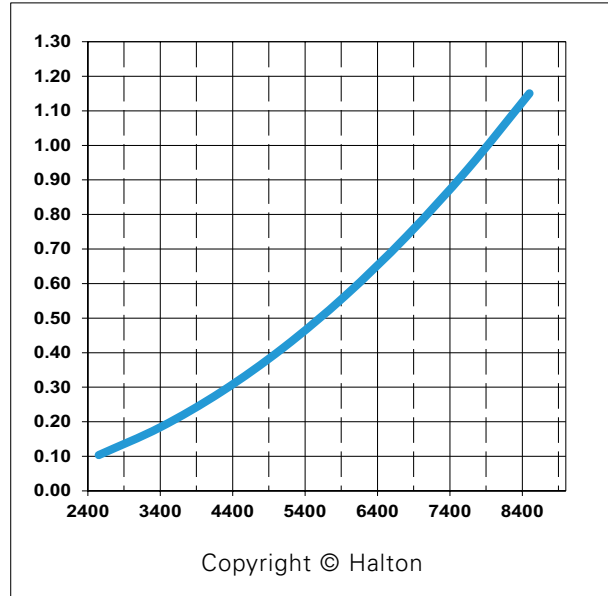

KVW-UV - 9 Filters

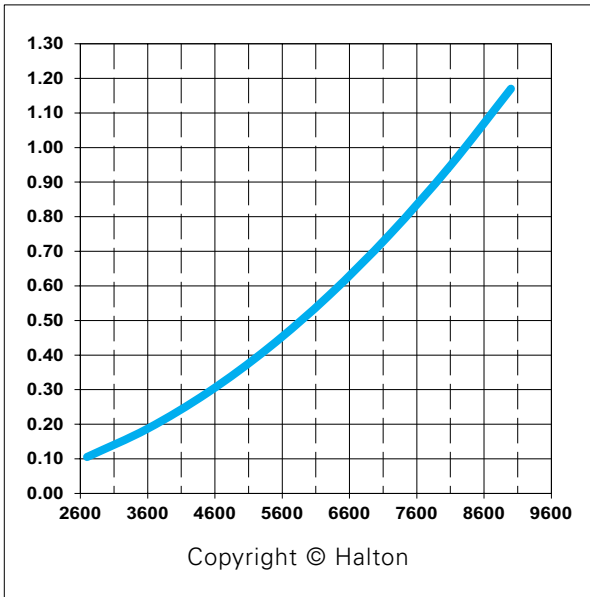

KVW-UV - 8.5 Filters

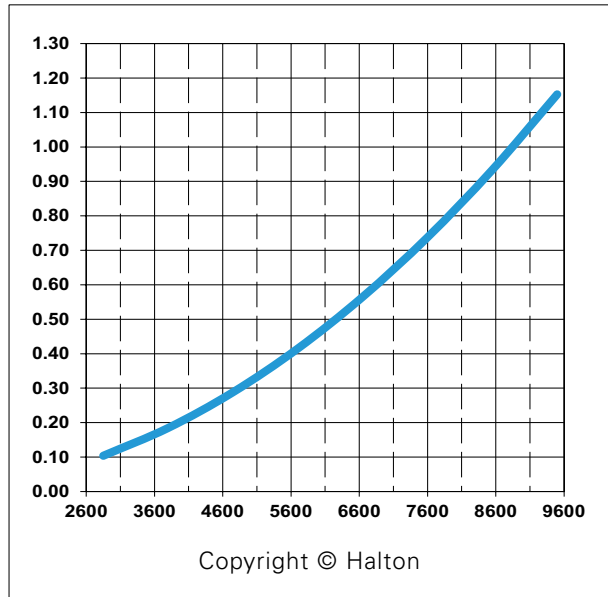

Suggested specifications

General

Kitchen hoods are constructed from 18 gauge stainless steel. The kitchen hoods shall be supplied complete with outer casing/main body, inner liner, exhaust duct, pressure measurement T.A.B. ports, fluorescent light fixtures, Capture Jet air supply nozzles, secondary filter, KSA grease filters, perimeter drain channel and collection cup. Outer casing panels shall be constructed of stainless steel with a brushed satin finish. Each joint shall be welded and liquid tight, avoiding harmful dripping of condensation.

All exposed welds are ground and polished to the original finish of metal. Canopy ends shall be double sided wall construction (no single wall hoods permitted).

Exhaust

The exhaust airflow will be based on the convective heat generated by the appliances underneath each hood system. Submittals shall include convective heat calculations based on the input power of the appliance served.

Capture Jet™ Tech

The hood shall be designed with Capture Jet™ technology to reduce the exhaust airflow rate required, and to improve the capture and containment efficiency of the hood, while reducing energy consumption. The Capture Jet™ air shall be introduced through a special discharge panel and shall not exceed 10% of the calculated exhaust airflow. The Capture Jet™ discharge velocity will be a minimum of 1500 feet per minute. Slot or grille type discharge shall not be used. The Capture Jet™ shall be internally mounted with a speed control and will not require a fire damper or electronic shut down in fire mode.

T.A.B.™ Ports

The airflows through the extractors and the Capture Jet™ air chamber are to be determined through the integral T.A.B.™ (Testing and Balancing) ports mounted in the hood. The airflows are to be determined by the pressure vs. airflow curves supplied by Halton.

Grease Filters

The hood shall be equipped with KSA multi-cyclone stainless steel grease extractors. The KSA filters shall be NSF and UL classified. The grease extraction efficiency is 93% on particles with a diameter of 5 microns and 98% on particles with a diameter of 15 microns or larger as tested by an independent testing laboratory. The pressure loss over the extractor shall not exceed 0.50" of water at flow rates approved by U.L. for heavy load cooking. Sound levels shall not exceed an NC rating of 55. Baffle or slot type extractors shall not be used.

HCL Halton Culinary Lights

Each hood shall be equipped with Halton Culinary LED Lights (HCL). Constructed from stainless steel frame and Aluminum hosing, the light fitting comprises flush-mounted broad beam spots with a diffusion angle of at least 80°. Each light is comprised of a patented mixing chamber and a specific reflector. Both shall provide a good balance between direct and diffuse light components without dazzling the staff to mitigate eye fatigue. The shielding angle shall exceed DIN 12464-1 requirement and be at least 30°. The illuminance on the working surfaces shall be code required 50-foot candles at the cooking surface with a CRI Color Rendering Index greater than 80. The wattage per fixture will be 14W. The LED's lifetime shall be 50,000 hours. The internal power supplies shall have at least the same lifetime. They shall enable switching on/off or dimming the light (0-100%) with one or several switches.

[Optional] Light Fixtures

Hood lights shall be U.L. Listed LED fixtures, suitable for grease hoods. 20 Watts per fixture, 50 foot candles at cooking surface. Option: Recessed fluorescent, recessed incandescent or incandescent globe type lighting. The lighting shall be suitable for single phase power supply. Dimmable LED option is available. Standalone Hood based dimming control on the switch panel. When M.A.R.V.E.L. controls are used, all hoods connected to the system can have the light intensity adjusted through the HMI touch screen simultaneously.

Control Panel

The master electrical panel consisting of one starter per motor with overload protection will be supplied. Control panel to hood or remote mounted. (For constant volume systems). M.A.R.V.E.L. controlled systems come with an HMI touch screen to monitor variable volume operation and incorporate the use of V.F.D.'s to control fan operation.

Access Panels

Each hood is provided with an access panel for easy access of the UV cassettes. The ballast access panel is located within the hood to provide access to components within the ballast box.

Capture Ray™

The system includes one stainless steel plenum to house the ultra violet cassettes. The hood is complete with a control panel indicating the total hours of operation, safety alarms, security on, and exhaust fan failure.

There are two sizes of UV cassettes:

- one short, which is (234W) 38" long
- one long, which is (390W) 66" long

Capture Ray™ (Continued)

The UV control panel is suitable for a single phase power supply and is constructed to meet the UL listed protection standard.

The cassette access plate includes a hinged door for ease of maintenance and replacement of the UV bulbs. The cassettes are mounted on a rack and are easily removed by disconnecting the electrical connectors on the cassettes end. The door comes equipped with safety switches. If the door is not secured in the closed position, the system will not operate.

The control panel is connected to the electrical box of the fan via a relay which detects any electrical fan failures. The system will not operate, if the fan does not work. The fan is not supplied by Halton.

The hood manufacturer supplies a master electrical panel consisting of overload protection, a main disconnect switch, terminal block wiring and control circuits that are pre-wired and contained in enclosures.

M.A.R.V.E.L. (Demand Control Ventilation)

Capture Ray hoods when used in combination with M.A.R.V.E.L. Demand Control Ventilation system shall optimize energy performance of the system by independently modulating the hood exhaust based on cooking activity. The reduction in fan energy as well as operating cost during non-peak or idle appliance use provides capture and containment of the heat load also ensures a comfortable work environment.

Form#: SS015_KVW-UV
Date: 06-2021 - Rev 3

The company has a policy of continuous product development, therefore we reserve the right to modify design and specifications without notice.

For more information, please contact your nearest Halton agency. To find it: www.halton.com