

Operators Manual for **ABD & MBD**

Manual provides
Operation, Maintenance and Service Instructions

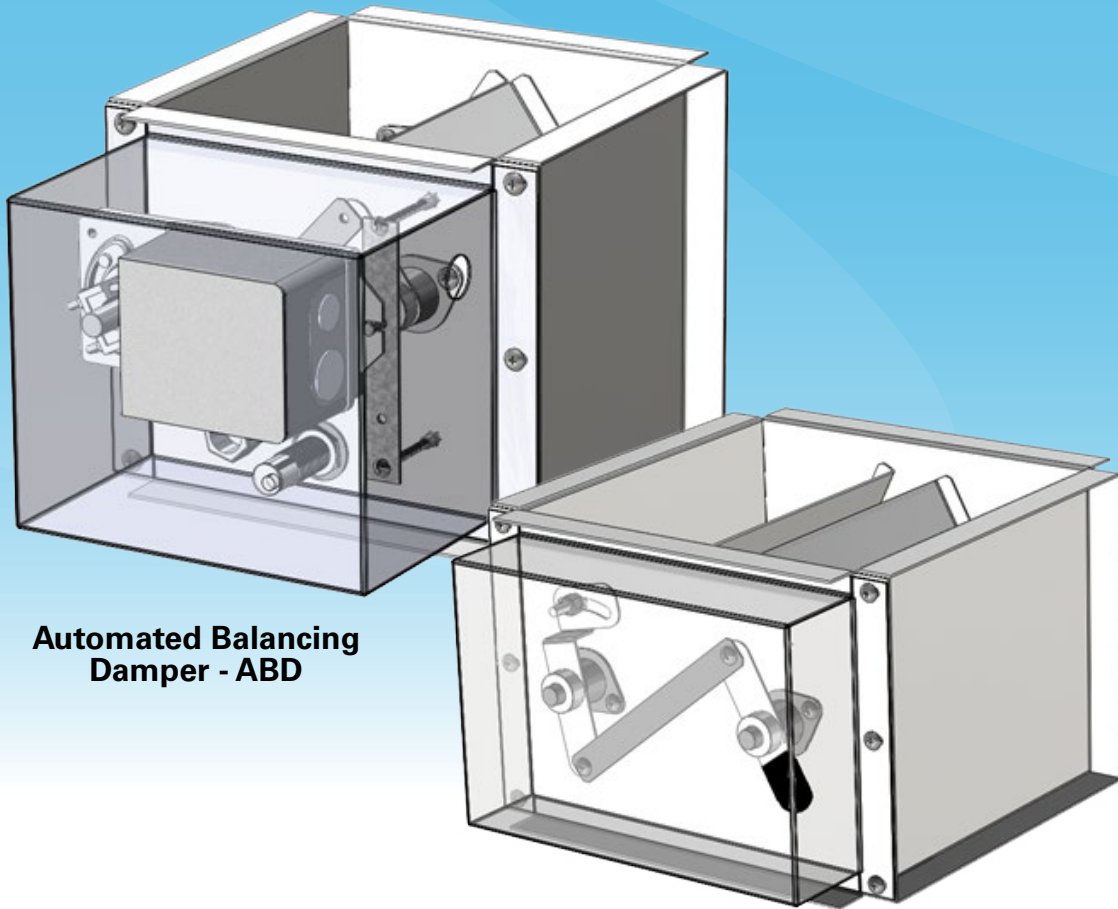

**Automated Balancing
Damper - ABD**

**Manual Balancing Damper
- MBD**



Exhaust Volume Dampers
Model: ABD & MBD

INSTALLATION INSTRUCTIONS

Carefully unpack the unit. Units may be installed vertically or horizontally. Check engineered drawings or job specifics on installation. Height requirements are shown on Figure 1.

Figure 2 shows typical installations. Halton dampers may be attached directly to the exhaust collar of a kitchen hood or they may be located downstream in the ductwork, as long as they remain in the same contiguous fire zone as the hood.

Set the unit on top of the exhaust collar of the kitchen hood, or at the location in ductwork prepared for it. The Balancing Damper has a 1" flange around the perimeter that should match up with the exhaust collar's 1" flange or a 1" flange on the exhaust ductwork. These flanges are to be continuously welded together. The 1" flange on the opposite end of the Balancing Damper will mate up with a 1" flange on the exhaust duct. These flanges are to be continuously welded together. Note that in the closed position the peak of the closed vanes point upward or toward the exhaust fan. See Figure 3. Ensure that vanes are pointing towards the exhaust fan for proper installation. See Figure 4.

Please note: Take all necessary precautions to prevent the body of the ABD damper from warping during the welding process. If the damper warps it may bind the damper blade bearings. Use common techniques to prevent warping including: avoid over welding, place intermittent welds on opposite sides of the damper, alternating the welding sequence around the damper's flanges until the continuous weld is achieved, and clamping the parts to be joined tightly together. Be sure all flammable materials are removed from the area where welding is to be performed.

The damper will have a cover on one of the short sides of the damper (unless the exhaust collar/duct run is square). This cover encloses the adjustment mechanism of the MBD (Manual Balancing Damper) or the actuation motor of the ABD (Automatic Balancing Damper). When installing on horizontal ductwork do not place the cover side pointing towards the floor. This face of the damper has shafts running through bearings and might allow grease to come through the shaft penetration and accumulate inside the cover. Install the damper so the cover side is horizontal or pointing upwards away from the floor.

The cover must remain accessible until the hood has been balanced in the case of the MBD, or until the control wires have been run to the motorized actuator or other components installed in the ABD, and tested for correct function. Do not fire wrap the ductwork in this area until these procedures are completed.

MAINTENANCE

The inside of the damper is accessible through the exhaust plenum of the hood. Clean as necessary.

ADJUSTMENT

The automatic damper will be operated by the damper controller. No adjustment is required at the time of installation. The manual damper (MBD) can be adjusted by first removing the cover over the adjustment mechanism (Fig 3 Item "A"). Loosen the ¼"-20 lock nut (Fig 3 Item "B") counterclockwise using a 7/16" wrench and then adjust the vane linkages (Fig 3 Item "C"). Adjust the vanes to achieve the hood's specified static pressure as measured at the exhaust plenum Testing And Balancing (T.A.B.) port. Tighten the ¼"-20 lock nut "B" against the adjustment slot after adjustment is complete. Please refer to the hood Operation and Maintenance manual for location of the T.A.B. port, and the job specific submittal drawings for the correct target static pressure.

Figure 1

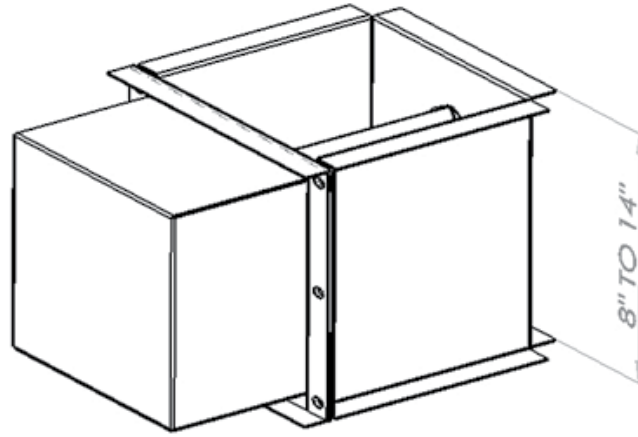

Figure 2

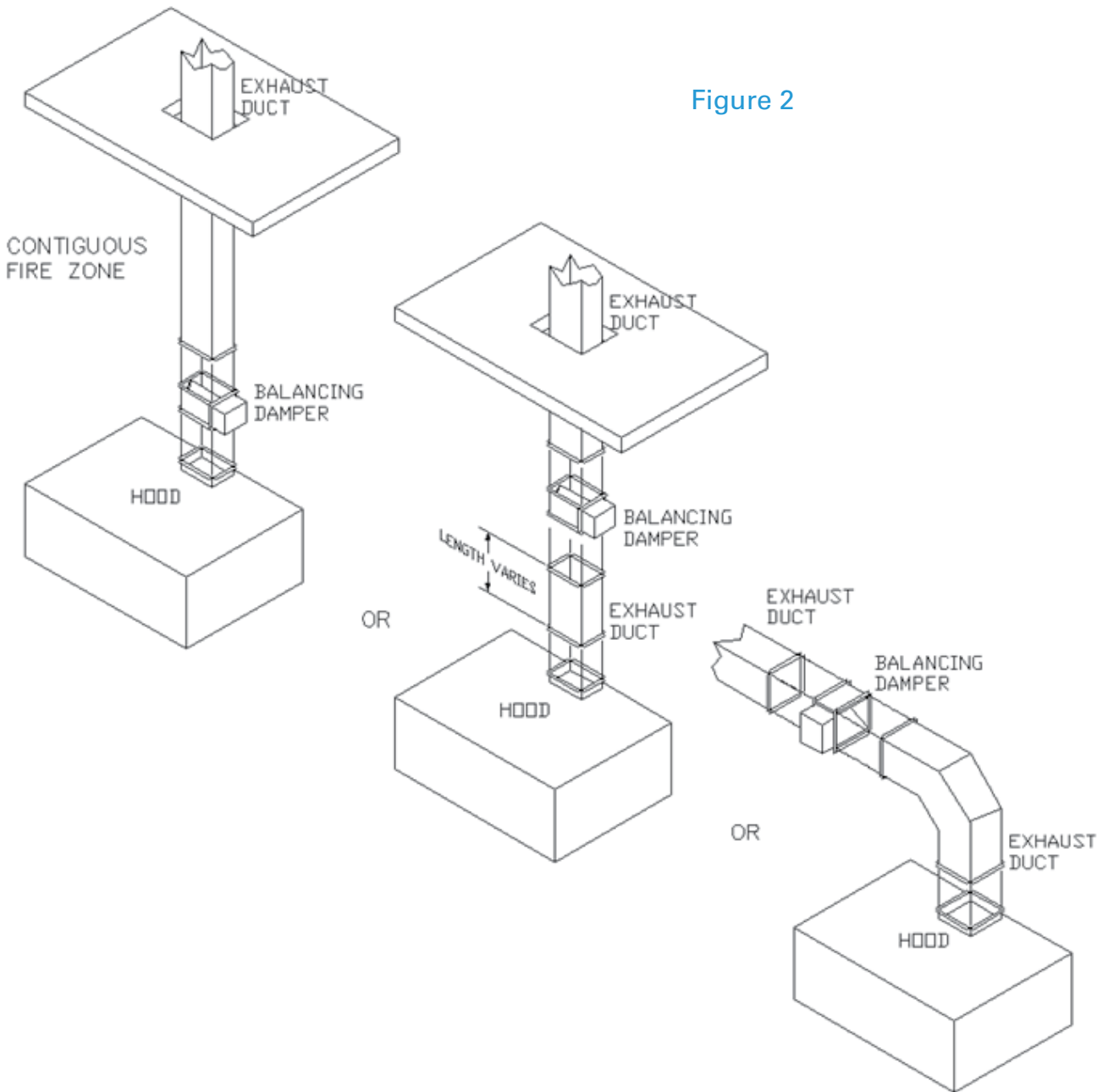

Figure 3

Vanes

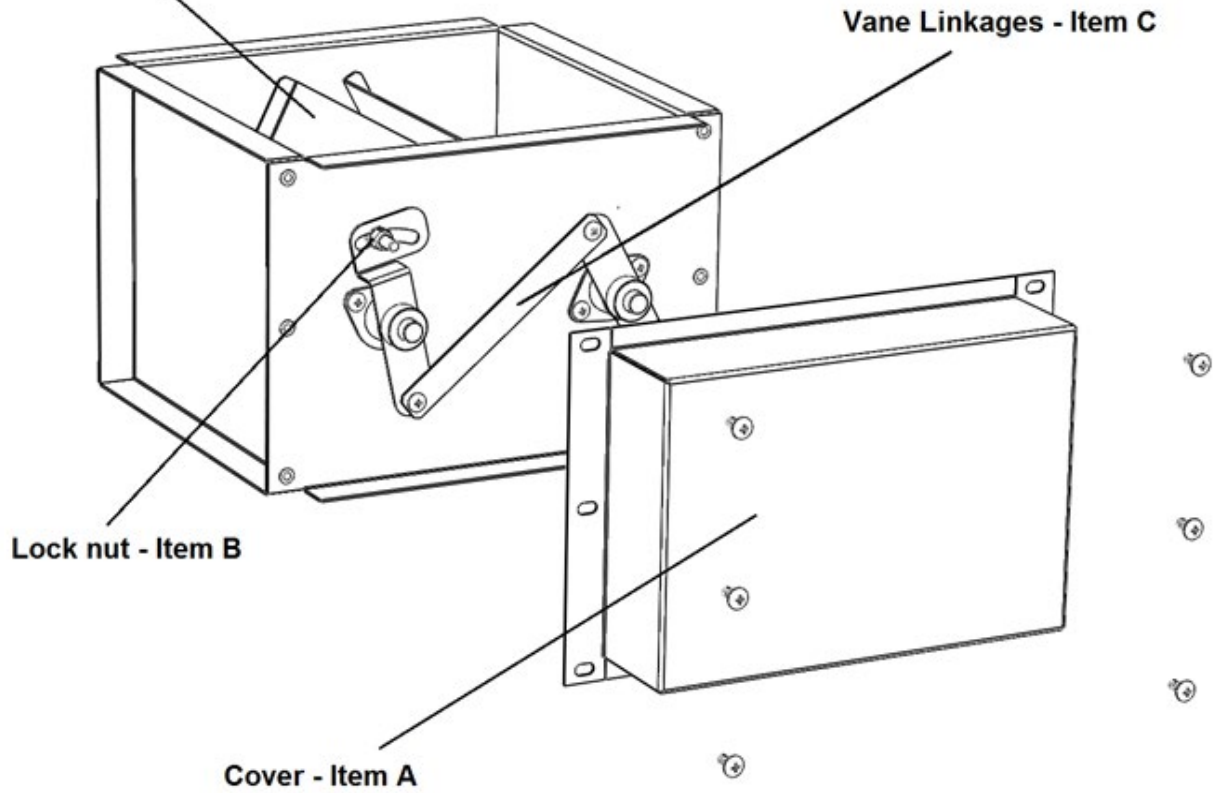
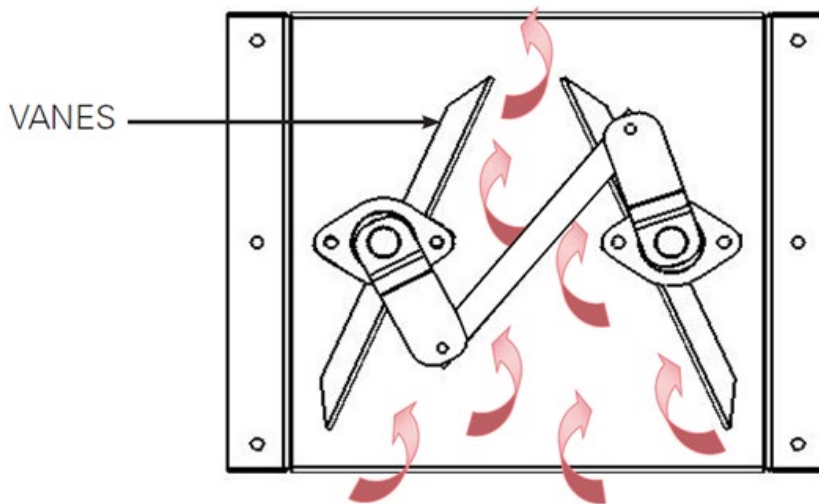

Figure 4



Ensure that vanes are pointing toward the exhaust fan for proper installation. Cross section showing air moving through damper.

Balancing Damper Actuator Removal/Replacement – ABD only

To remove and replace the actuator on the ABD balancing damper, follow these steps:

1. Remove exterior metal cover by removing the 6 mounting screws around the perimeter.
2. Remove the actuator cover by removing the 1 screw on the side.
3. Disconnect the power to the actuator. Note positions of white, red and blue wires on terminals 1, 2 and 3 respectively.
4. Record the DIP switch values, located at the wiring terminal strip end of the actuator.

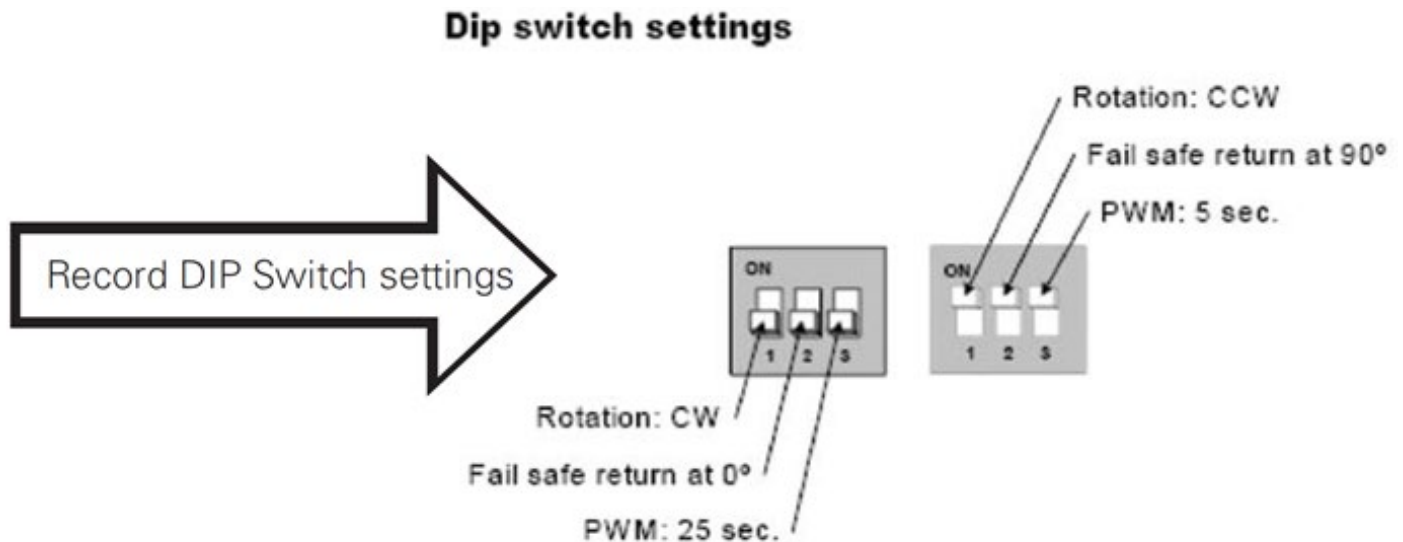

5. Note the position of the stop screws.

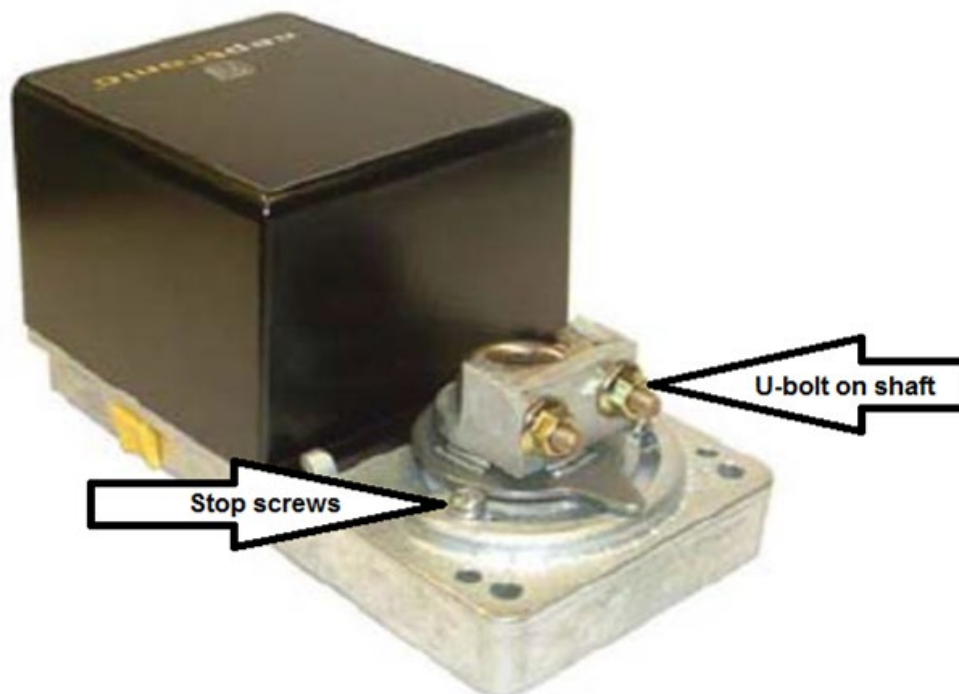

6. Remove the U-bolt that attaches the actuator to the balancing damper shaft. Refer to the Actuator Specification and Installation instructions with the replacement part.

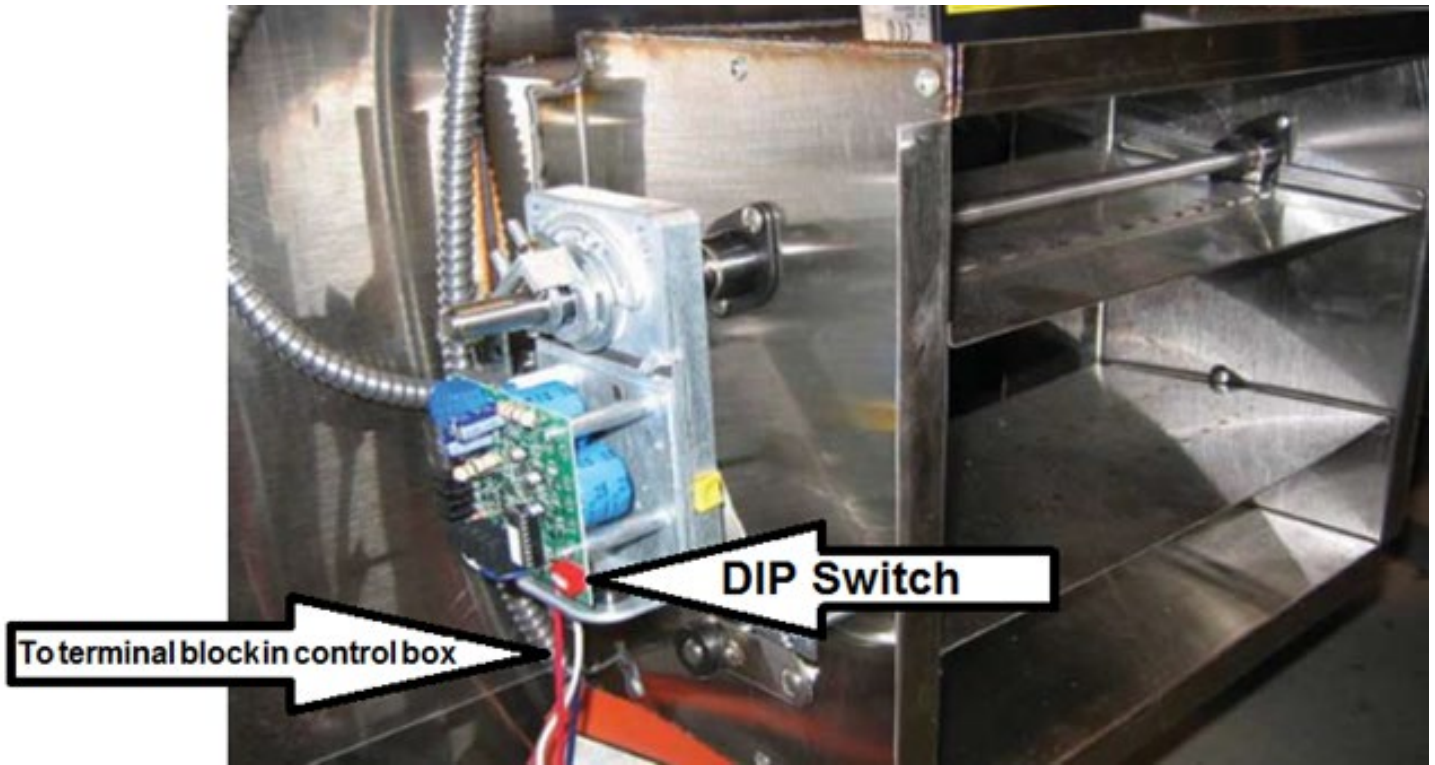

7. Replace with a replacement actuator (Halton Part # 16012). Tighten the U-bolt on the drive shaft.

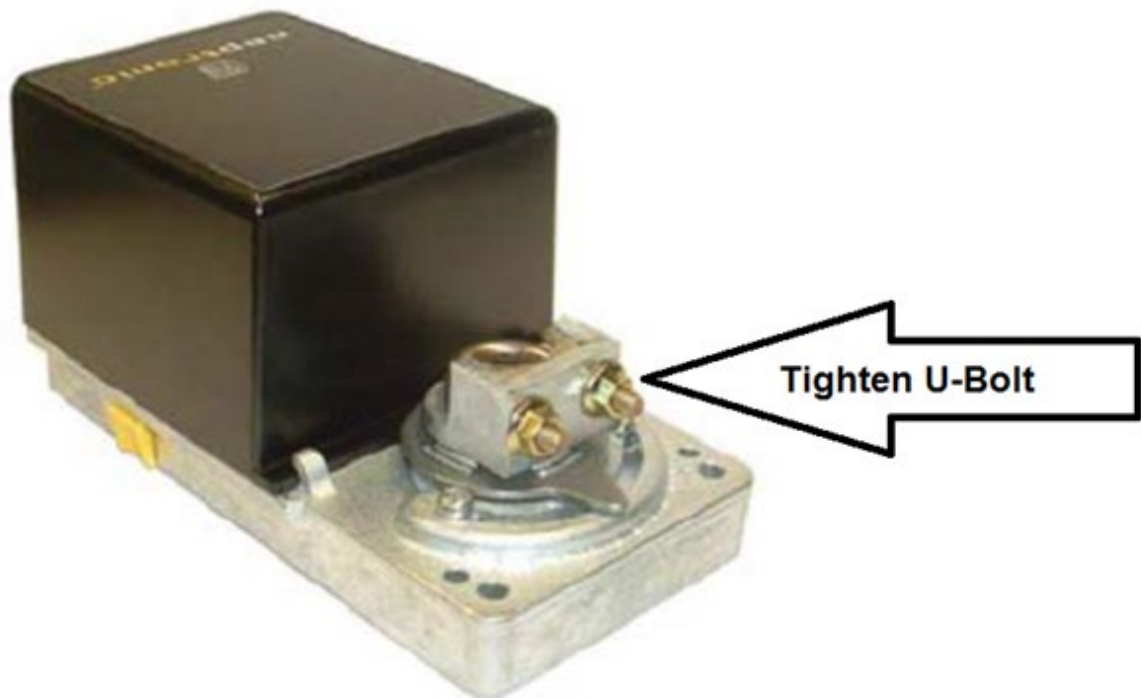

8. Reset the DIP switches.
9. Reset the stop screws.



10. Reconnect wires. White wire to terminal 1, red to 2, blue to 3.
11. Calibrate the new actuator by pressing the Reset button. The dampers will open and close.

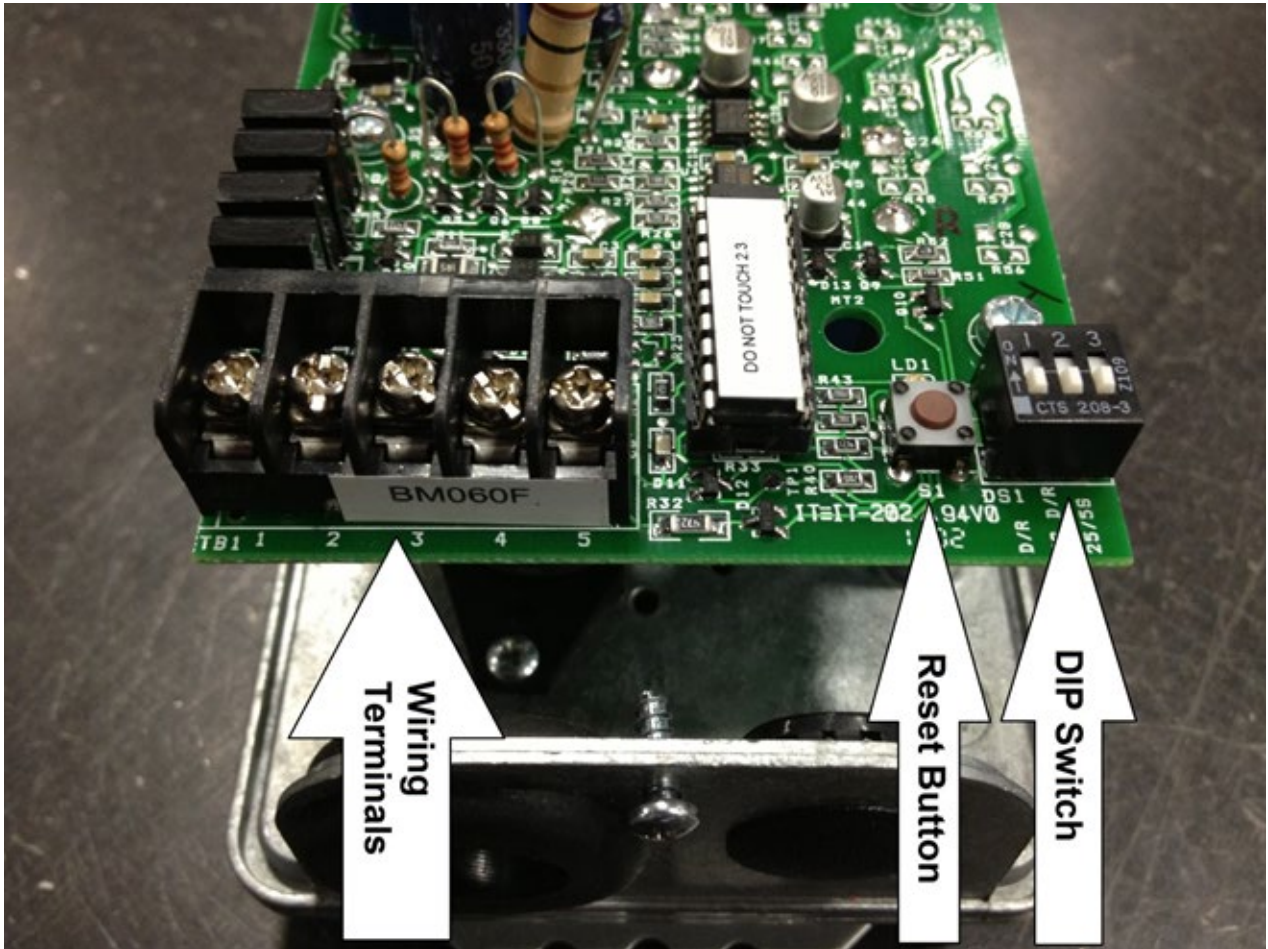

12. Replace the actuator housing and the exterior metal cover as before.

Duct Safety and Monitoring System (KGS) and Temperature Sensor – ABD only

Halton's Duct Safety System (KGS) is a signaling device that monitors the grease deposition levels in all monitored ductwork. The ABD damper incorporates this signaling device into its construction. Once the level of grease exceeds the set point threshold an alarm is displayed on the Marvel system Touchscreen alerting the operator that the ductwork needs to be cleaned. Optionally a signal can be sent to the Building Management System (BMS) via a dry contact closure. The system also gives an indication whether the cleaning was done satisfactorily.

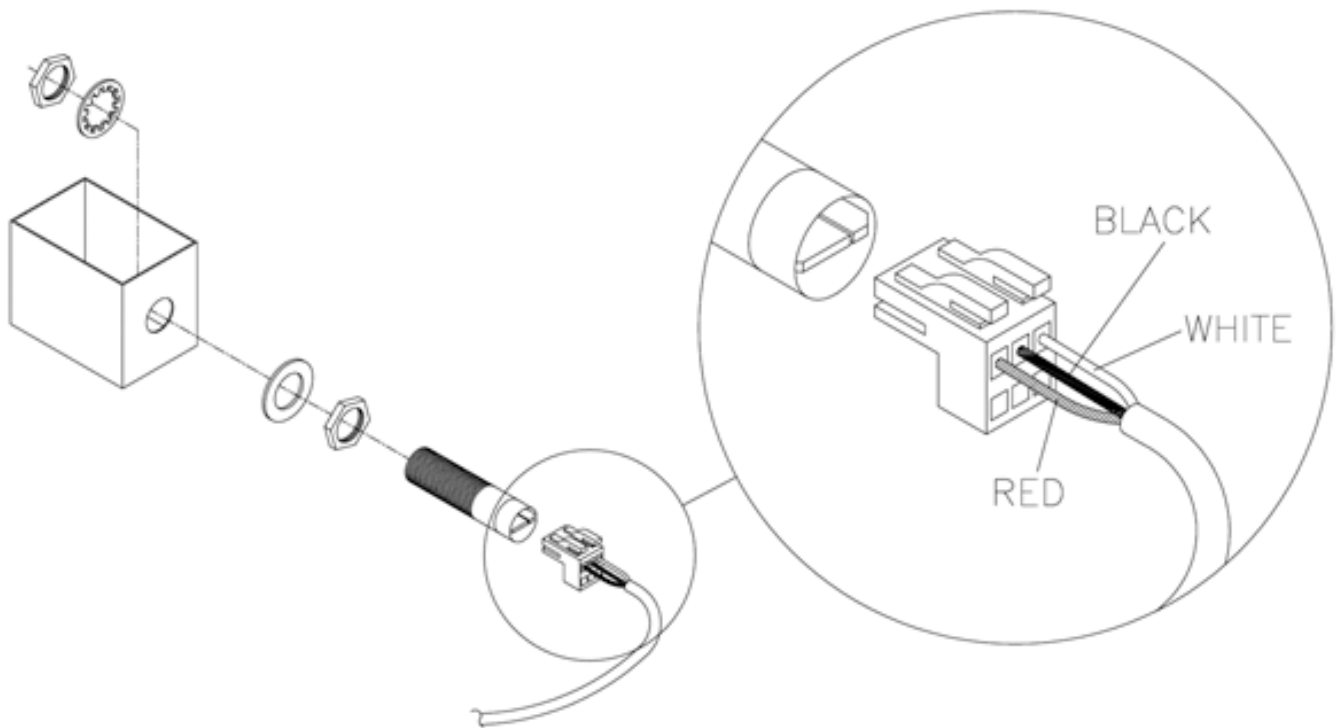
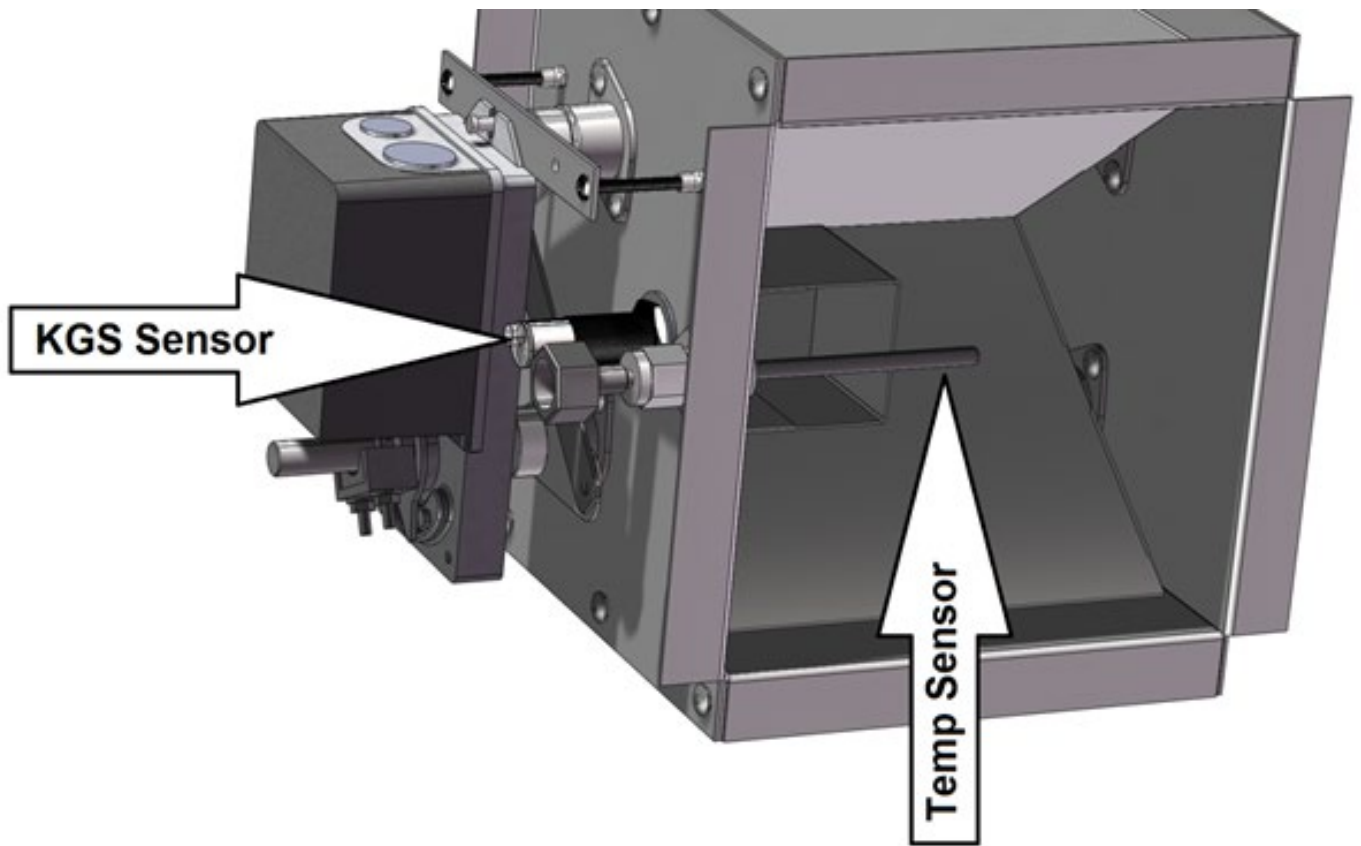

Maintenance Instructions

Duct Safety and Monitoring System (KGS)

The KGS system should only be cleaned when the entire duct system is cleaned. Always inspect at cleaning each grease sensor and insure reflective surface and lens are clean. When cleaning, do not use steel wool or other abrasive materials that would scratch the reflective material or lens.

The KGS system must be inspected after each 12 months of service. To schedule inspection, contact your authorized service agent or consult the factory for additional details.

The grease sensors have a typical life span of five years. After five years, the grease sensors must be replaced. For replacements, contact your authorized service agent or consult the factory for additional details

Parts List

Description	Part Number
Grease Sensor	11160
Grease Sensor Gasket	11164
M18 Lock Tooth Washer	11165
Reflector Assembly	No Part Number

****Note - Hex nuts are included with Grease Sensor, Part No. 11160****

Temperature Sensor

Temperature Sensor Removal/Replacement

To remove the temperature sensor located in the damper body, follow these steps:

1. Disconnect the temperature sensor from the terminal block located in the M.A.R.V.E.L. Control Panel. Refer to the terminal block diagram on the Halton-supplied wiring diagram for the correct terminations points.
2. Unscrew the tightening collar on the Evergreen fitting which holds the temperature sensor.
3. Remove the temperature probe.
4. Replace the defective temperature probe with a replacement (Halton Part # 17641)
5. Reconnect wiring.

Please see your M.A.R.V.E.L. system Operation and Maintenance manual for complete information about the KGS sensor and the Temperature Sensor