

# *Operators Manual*

Operation, Maintenance and Service



**KVH**  
**Kiosk Ventless Systems**



**Halton**

## GENERAL INSTALLATION

Upon receipt of the Halton hood, inspect it immediately for any shipping damage and notify carrier immediately if damage is found. Halton will not accept responsibility for any shipping damage, but will assist in helping getting a claim filed if needed.

It is the responsibility of the installing contractor to see that the system installation is completed in accordance with the project plans and specifications and that it meets all specific requirements of local code officials. The local authority having jurisdiction could overrule some of the installation details written in this manual. The installation shall be in accordance with NFPA-96. All electrical systems shall be installed following local and national codes.

It is very important that the system be turned over to the owner in the best condition possible. The owner and/or operator should be instructed in the proper operation, care and maintenance of the system.

## INSTALLATION INSTRUCTIONS

1. Inspect the crating carefully. If there are signs of damage, call the freight carrier before uncrating the unit. Carefully uncrate the unit. **\*\*Important note\*\*** Do not leave unit out in the weather for a long extended time period. The protective PVC around the hood will become very difficult to remove if left exposed to the weather conditions for a long period of time.
2. Position the hood near the actual installation. Check Engineered set of drawings for location.
3. Hood is shipped lying on its back. Carefully uncrate the top protective structure of the crate. Do not use the hood for leverage while removing protective structure. While hood is still on its back slide hood toward the base of the unit until it overhangs the end of the pallet.
4. Attach the four feet to the bottom of the unit. Tighten securely.
5. Fasten the exhaust diverter/fire damper assembly to the top of the unit. Place the diverter/damper assembly over the exhaust outlet and align the six mounting holes with the threaded fasteners in the top of the hood. Tighten mounting screws securely.
6. Stand unit on its feet by bracing the unit stationary at the back two legs and lifting at the rear upper edge of hood. **CAUTION:** Unit is top heavy. Use extreme caution and as much assistance as necessary while standing unit up to the upright position! Do not attempt this with only one person.

7. The fire suppression system must be charged and prepared for use before hood is placed in operation. A manual pull station must be installed as part of this system. See section on fire suppression system for complete details. The fire suppression system is accessed through the rear cover panel. Depending on final location of hood this work may need to be done before final placement of hood.
8. Locate hood in final position. Clearance from combustible surfaces shall be 0" from the back, and 0" from left side and 3" from the right side.
9. Make sure hood is level, vertical, and does not rock. Adjust the unit's feet as required.
10. Connect electrical circuits accordingly. A wiring diagram is shown in illustration 3. Unit must be connected to building service with 8 AWG copper wire minimum.
11. Make sure the carbon filter and the KSA grease filter, and the grease cup are installed in place before start up. Appliance outlet will not energize unless all filters are properly installed. The Carbon filter installs first. There is an inner track for the carbon filter to slide into. The yellow prefilter side of the carbon filter should face the operator when installed, the perforated steel side of the carbon filter should face the exhaust fan and blower. An access notch at the top of the track allows the filter to slide sideways from left to right and press into the track. Slide the carbon filter downwards all the way to the bottom of the track where it will depress a button switch. This button switch is an interlock that allows power to the appliance when the carbon filter is in place (when remaining interlock switches are also actuated).

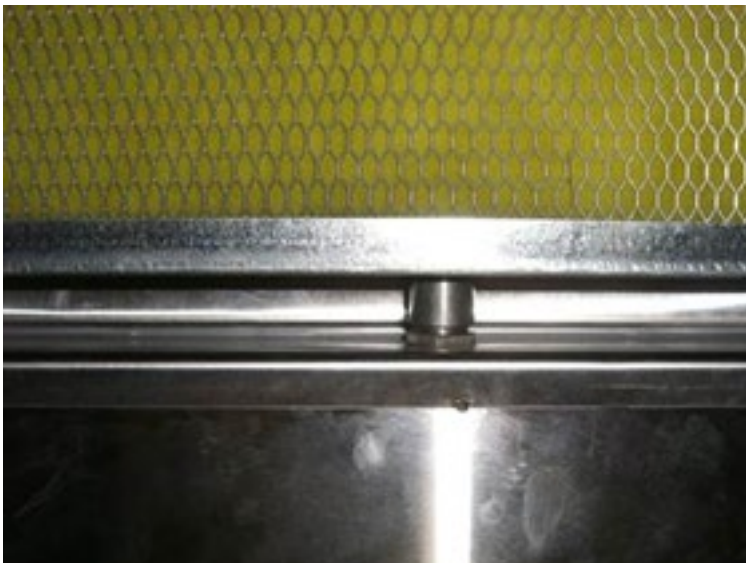

The KSA filter must be lifted into the filter opening bottom first. Push the top of the filter into the opening and then pull the filter forward against the filter brackets. Slide the filter downward to engage the hooks on the filter onto the filter brackets.

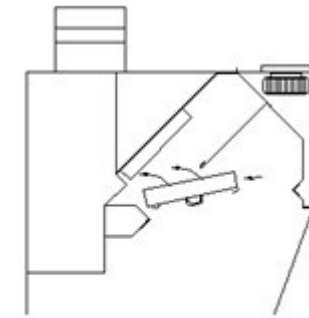
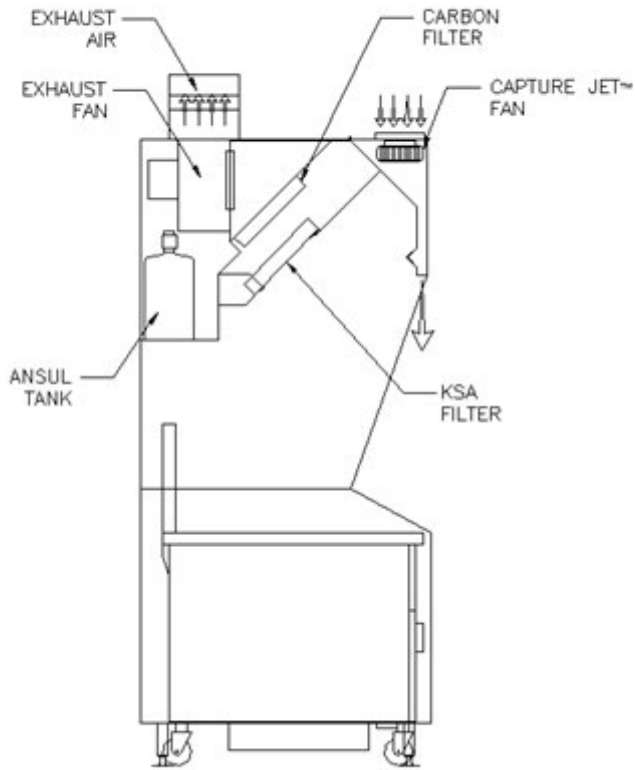

LIFT FILTER INTO PLENUM

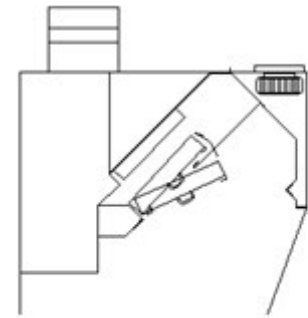

TILT TOP OF FILTER IN, PUSH FILTER IN AND DOWN

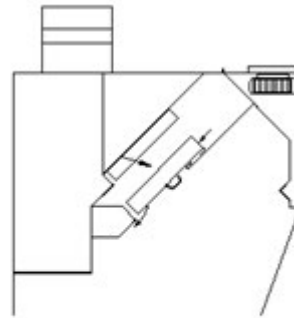

LIFT FILTER TO THE FRONT, SLIDE FILTER DOWN

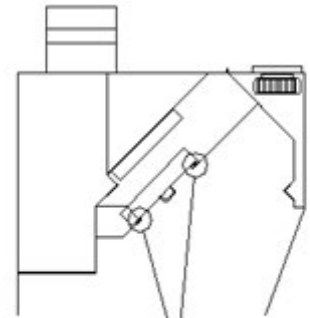

IT IS IMPORTANT THAT THE TOP LIP AND BOTTOM LIP OF THE FILTER ARE HOOKED CORRECTLY

The KSA filter must actuate the KSA filter interlock switch when it is installed in the hood.

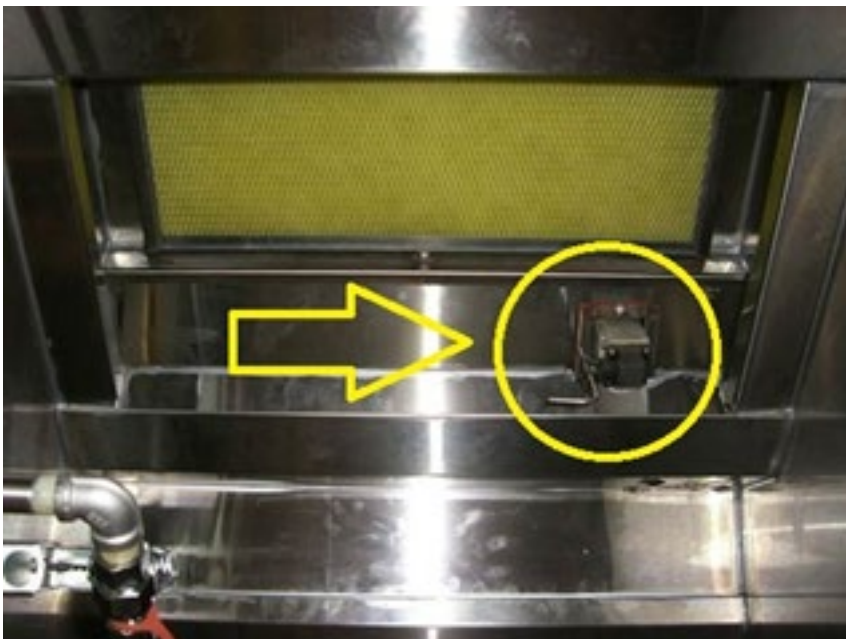

## FILTER IDENTIFICATION

CARBON FILTER

KSA FILTER

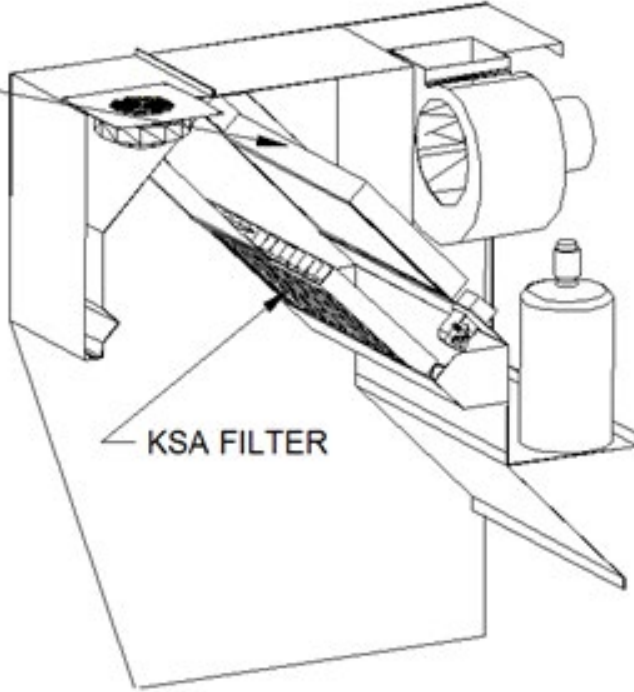

12. Place the appliance to be installed under this hood near the hood opening and plug the appliance into the outlet provided for it. Note the appliance limitations listed on the hood nameplate, and the electrical amperage limitations listed on the signage near the outlet. Comply with all displayed ratings, warnings and limitations.
13. After appliance is plugged into the outlet, carefully roll appliance under the hood until the appliance is completely within the hood. Be careful the power cord for the appliance does not kink or bind while rolling appliance into position. Be sure the power cord does not lie against surfaces of the appliance which will become hot during appliance operation.
14. Until the unit is placed into service, protect the outer surface from getting scratched under normal jobsite conditions.

## OPERATION OF SYSTEM

After installation is complete check operation of hood fans and appliance outlet. The control panel contains the hood power switch, the appliance power reset button, an indicator light for fan power and an indicator light for appliance power (see illustration 4). The hood power switch must be in the on position and the exhaust fan operating normally before the appliance power will be maintained.

1. Turn the hood power rocker switch to the on position (fan indicator light will illuminate). Exhaust fan and Capture Jet fan will turn on.
2. Press reset button (appliance indicator light will illuminate).
3. Set up appliance according to appliance manufacturer's operating instructions.

All filters must be in place and exhaust fan must be operating normally before appliance power will remain energized.

## HOOD MAINTENANCE

Before performing maintenance on hood turn off hood power rocker switch. Roll appliance out of hood enclosure and unplug appliance, if desired.

1. Clean the hood canopy and enclosure inside and out as needed with mild soap and water.  
**CAUTION:** Do not introduce water or any object into the appliance outlet receptacle. Never use harsh or abrasive cleaners on Stainless Steel or Painted surfaces.
2. Clean the grease filter and grease cup daily, first washing by hand, then placing them into a dish washer or by steam cleaning. **\*\*Handle the Grease filters carefully\*\***
3. The entire hood plenum and the blower section shall be cleaned a minimum of once every 3 mths.
4. Inspection and testing of the total operation and all safety interlocks in accordance with these instructions (see next section) shall be performed by qualified service personnel a minimum of once every 6 months or more frequently if required.
5. Inspection and maintenance of the fire suppression system shall be made by properly trained, qualified and certified persons at least every 6 months.
6. Sign and date the accompanying maintenance log (make copy of illustration 5) when performing required maintenance. This maintenance log must be available on the premises for use by the authority having jurisdiction.
7. The carbon filter should be inspected periodically for grease build up or deterioration of the pre filter element. This should be done minimally every 3 months, or more often depending on the cooking load. To remove the carbon filter, turn off hood exhaust fan. Roll appliance out of the way, if desired. Open the access panel above the KSA grease filter by loosening the screws at the top

of the panel. The access panel will swing towards the operator and downwards, take proper precautions to guard against injury when it opens. Slide the carbon filter upwards in its retaining channel until it is at the top of the channel. Slide filter to the right to remove it from the channel. Turn the filter a quarter turn to the left or the right in order to remove it through the access panel. Replace the filter with a new one or return the original filter by performing the above in the reverse order.

#### Halton Replacement Filter Part Numbers

12-3/8 X 20 X 2 Carbon Filled Filter	10703
13 X 20 KSA filter	KSA 13"

## SAFETY INTERLOCK INSPECTION

Every 6 months the following checks should be made on the safety interlocks. These interlocks will de-energize the power outlet for the cooking appliance if the filters are not in place and properly positioned, or the airflow through the hood drops too low (due to filter clogging or improper fan operation). The air flow interlock will also not allow the appliance power outlet to be energized if the exhaust fan is not turned on first.

To test interlocks:

With the hood power switch in the on position and the exhaust fan running, press the reset button to energize the appliance outlet. Remove the KSA grease filter. The Appliance power indicator light should go out, indicating the appliance outlet has been de-energized.

1. Press down on the switch bar interlock lever for the KSA filter to simulate the KSA filter's presence. Press the reset button to re-energize the appliance outlet. The appliance power indicator light should come on. Lift the carbon filter an inch or so from its resting position, upwards along its bracket. The Appliance power indicator light should go out, indicating the appliance outlet has been de-energized.
2. Replace in their proper positions the carbon filter and the KSA grease filter. Press the reset button to energize the appliance outlet.
3. Place regular sheets of 8-1/2" X 11" paper over the grease filter's intake slots. (Three sheets of paper should be enough.) Cover all but the last two or one intake slots. The Appliance power indicator light should go out, indicating the appliance outlet has been de-energized.
4. Remove paper covering KSA grease filter and press reset button to place hood back into service.



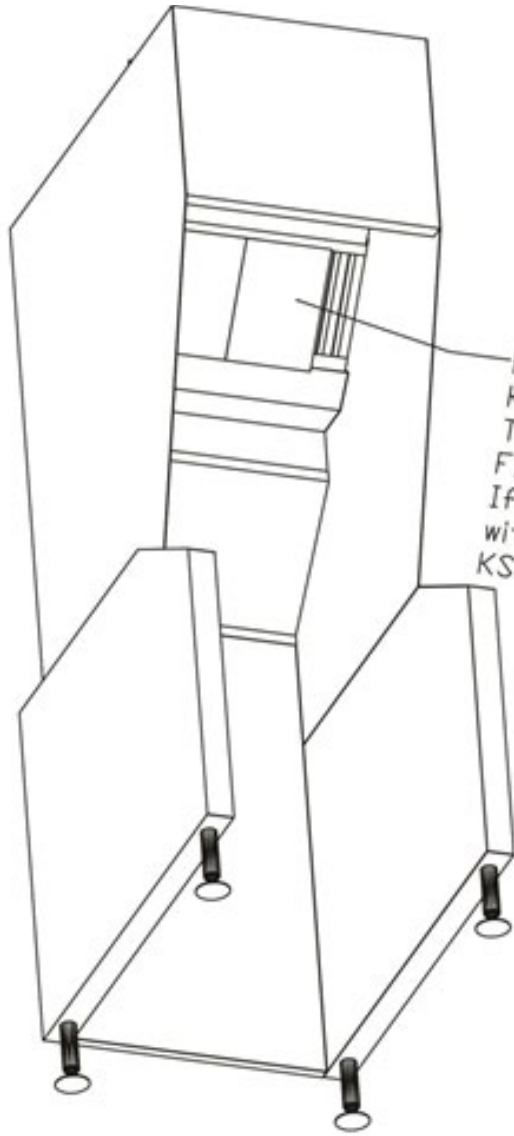

PLACE PAPER TO COVER  
 KSA FILTER UNTIL ONLY  
 TWO SLOTS OF THE KSA  
 FILTER ARE SHOWING  
 If KVH appliance circuit turns off  
 with more than 2 slots open on the  
 KSA filter - turn screw CCW



Air Switch  
 CW increases setpoint  
 CCW decreases setpoint

## FIRE SUPPRESSION SYSTEM

This hood is equipped with a pre-engineered, installed fire suppression system which complies with Standard UL 300 (See illustration 1). The hood's fire suppression system must be charged, and a remote manual activation device installed, before placing unit into service. This work must be done by properly trained and certified personnel. The fire suppression system requires periodic inspection and maintenance. Maintenance must be conducted at six month intervals, or earlier if the situation dictates. Twelve year maintenance must include agent tank hydrostatic testing.

1. The fire suppression system is accessed for charging and maintenance by removing the rear panel.
2. The remote manual pull station is required and must be mounted at a point of egress and positioned at a height determined by the authority having jurisdiction. The remote manual pull station may be mounted on the unit, if desired. The mounting location on the unit should be agreed upon by the local authority having jurisdiction, the properly trained and certified fire suppression system installer and the owner. **WARNING!** Do not mount the manual pull station on the front of the unit. Doing so may result in injury to the person activating the fire suppression system. The manual pull station may be mounted on either side of the unit, at a distance of 12 inches or further back from any front edge. See illustration 1.
3. Provision is made at the rear panel of the unit for the remote manual pull station connection.
4. If the fire suppression system activates, the power supply to the exhaust and Capture Jet fans, and the appliance outlet, will be de-energized.
5. For continued fire protection, the fire suppression system must be recharged immediately after

Shaded area represents locations the manual pull station may **not** be mounted.

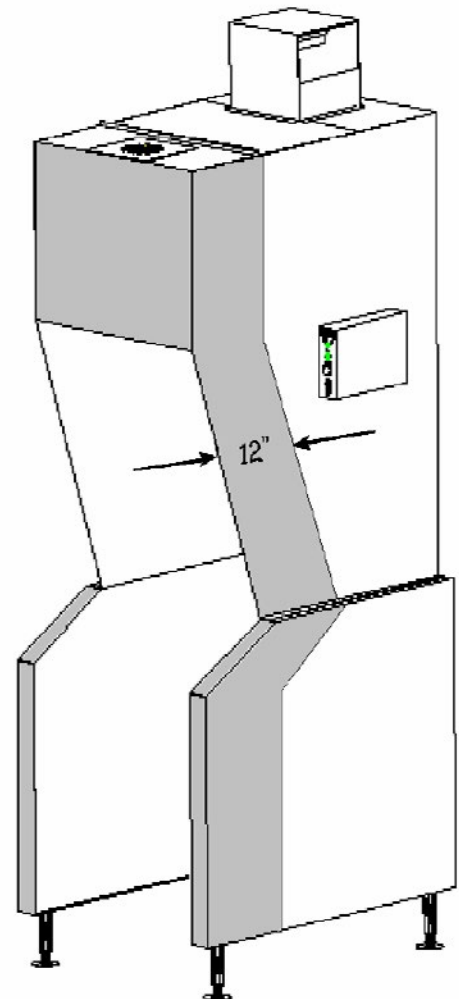

**Illustration 1**

HOOD MODEL KMD  
ANSUL R-102 SYSTEM  
TYPICAL DETAIL

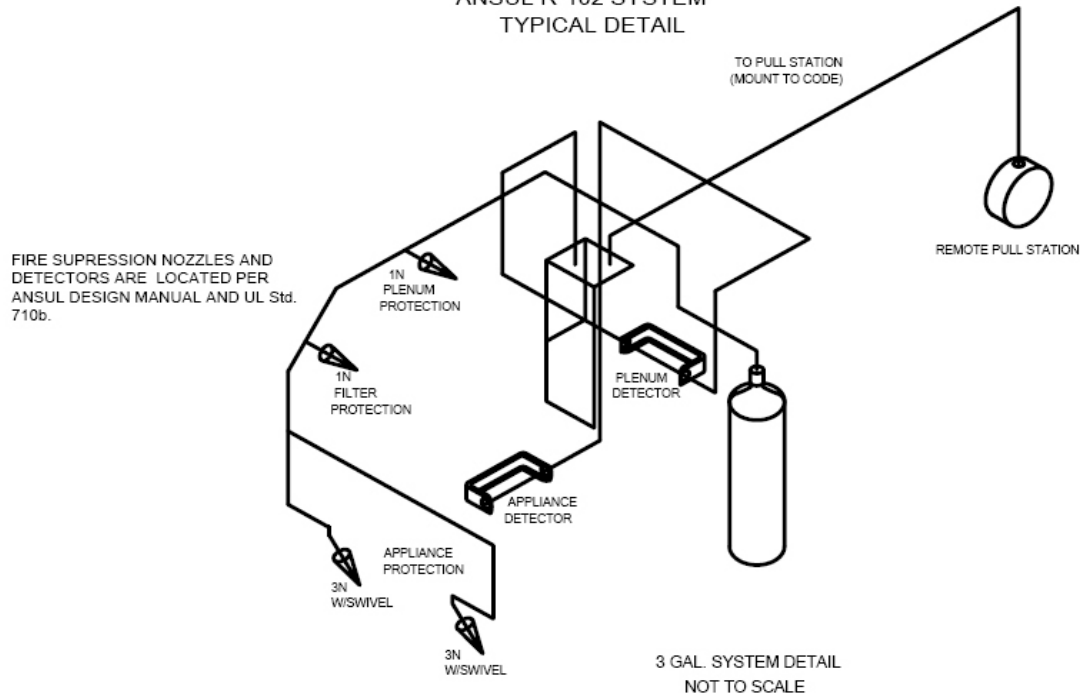

ITEM	PART No.	DESCRIPTION
1	429862	3 GAL. AGENT TANK ASSY.
2	79493	OEM RELEASE/BRACKET ASSEMBLY
3	419338	NOZZLE, TIP NO. 3N
4	419335	NOZZLE, TIP NO. 1N
5	423439	CARTRIDGE SHIPPING ASSEMBLY (101-20)
6	417368	TERMINAL DETECTOR
7	417369	SERIES DETECTOR
8	77284	3/8" "QUICK SEAL" ADAPTOR
9	79152	1/2" EMT COMPRESSION-SEAL ADAPTOR
10	4835	REMOTE PULL STATION ASSEMBLY
11	77411	BLOW-OFF CAP SHIPPING ASSEMBLY.
12	423878	ELECTRIC SWITCH ASSEMBLY (SPDT)

GENERAL NOTES:

1. THIS INSTALLATION IS TO BE MADE IN ACCORDANCE WITH THE R-102 INSTALLATION MANUAL AND IN ACCORDANCE WITH ALL STATE AND LOCAL CODES.
2. THE WIRE ROPE FOR THE DETECTOR AND REMOTE PULL STATION IS TO BE INSTALLED BY AN AUTHORIZED AND FACTORY TRAINED DISTRIBUTOR OR SERVICE REPRESENTATIVE.
3. THIS INSTALLATION IS TO BE INSPECTED, PUT INTO OPERATION AND CERTIFIED BY AN AUTHORIZED AND FACTORY TRAINED DISTRIBUTOR OR SERVICE REPRESENTATIVE.
4. ANSUL R-102 RESTAURANT FIRE SUPPRESSION SYSTEMS HAVE BEEN TESTED AND ARE LISTED BY UNDERWRITERS' LABORATORIES INC. AS PRE-ENGINEERED SYSTEMS, AND WHEN INSTALLED AS SHOWN ON THIS DRAWING SHALL COMPLY WITH ALL RELEVANT ANSUL INSTALLATION RECHARGE INSPECTION AND MAINTENANCE MANUALS AND SHALL COMPLY WITH NFPA 96 WHEN INSTALLED AND CERTIFIED BY AUTHORIZED TRAINED ANSUL DISTRIBUTORS IN ACCORDANCE WITH THE MANUAL.
5. ALL AGENT DISTRIBUTION PIPING AND DETECTION CONDUIT HOOD PENETRATIONS MUST BE PROPERLY SEALED IN ACCORDANCE WITH NFPA 96.

DISTRIBUTION PIPING REQUIREMENT NOTES:

1. PIPE SHALL BE 3/8" SCHEDULE 40 STAINLESS STEEL.
2. FINAL NOZZLE LOCATION MAY NOT VARY FROM LOCATION SHOWN.

Illustration 2

# Typical Wiring VENTLESS HOOD

## \*\*\* NOTE \*\*\*

1. USE 8 GA WIRES FROM OUTLET BOX TO TERMINAL BLOCKS. FROM TERMINAL BLOCKS TO OUTLET CONTACTOR AND FROM OUTLET CONTACTOR TO OUTLET.
2. USE 12 GA WIRES FOR CONNECTIONS FROM TERMINAL BLOCKS TO MOTOR CONTACTOR AND FROM MOTOR CONTACTOR TO MOTOR.
3. REMAINING WIRES WILL BE 18 GA.

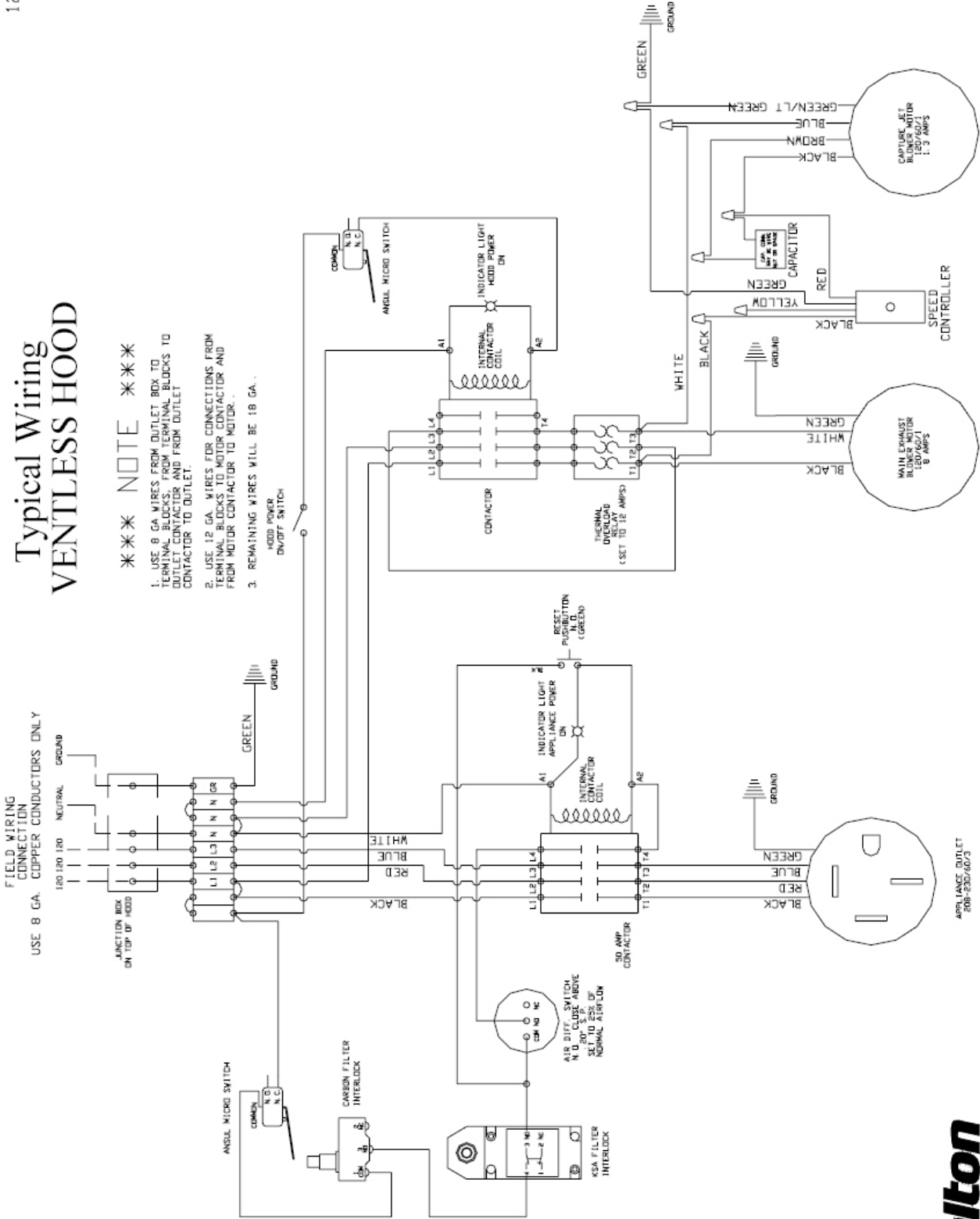

**Halton**  
CARE FOR INDOOR AIR

Illustration 3

# **Halton**

**CARE FOR INDOOR AIR**

APPLIANCE



FAN



RESET

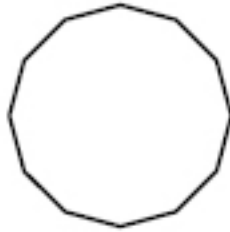

ON



OFF

**Illustration 4**

<b>Date</b>	<b>Visual Insp.</b> (Filters, hose, Ansul, etc.)	<b>Safety Interlocks</b> (Remove filters and check)	<b>Airflow Switch</b> (Cover KSA filter and check)	<b>Cleaning</b> (filters, exhaust plenum, blower)

Enter date, sign in box when item inspection or task is complete.  
 Do not fill out original – make photocopies of this form.

**Illustration 5**

# WARRANTY ACTIVATION FORM

This form must be completed and returned to Halton in order for your warranty to be valid.

## **Job & Location Information:**

Job Name: \_\_\_\_\_

Street Name: \_\_\_\_\_

City: \_\_\_\_\_ State: \_\_\_\_\_ Zip Code: \_\_\_\_\_

Equipment Start-Up Date: \_\_\_\_\_ Product Serial Numbers: \_\_\_\_\_

\_\_\_\_\_

\_\_\_\_\_

## **Contact Information:**

Contact Name: \_\_\_\_\_

Title: \_\_\_\_\_

Chef, Kitchen Mgr/Facility Mgr/Property Mgr/etc.

Facility Management Company Name (if applicable): \_\_\_\_\_

Email: \_\_\_\_\_

Phone Number: \_\_\_\_\_ Cell Number: \_\_\_\_\_

Fax completed form to:

**Halton Company**

**Attention: Service Department**

Fax: (270) 237-5700

**Halton Indoor Climate Systems**

**Attention: Service Department**

Fax: (905) 624-5547



# HALTON LIMITED WARRANTY

Halton ("Manufacturer"). Warrants only to its direct purchasers and to no others, that all products manufactured by the Manufacturer shall be free from defect in materials and workmanship for a period of twelve (12) months from the date of the original installation and start-up or eighteen (18) months from date of shipment, whichever occurs first. All products sold but not manufactured by Manufacturer will be warranted for a period of twelve (12) months from date of shipment. (Halton's Warranty Card must be completely filled out and returned to Halton within 3 weeks after the equipment start-up date for your warranty to be valid \*IMPORTANT NOTE: "IF" this form is returned within the specified time frame, Halton will extend your standard warranty by 120 days.)

For products manufactured by the Manufacturer we agree to pay any reasonable labor costs necessary to repair or replace, at Manufacturers option, defective parts or materials for a period of twelve (12) months from date of original installation and start-up or eighteen (18) months from date of shipment, whichever occurs first. All labor costs subject hereto shall be performed during standard work hours at straight-time rates.

For products sold but not manufactured by the Manufacturer we agree to pay any reasonable labor costs necessary to repair or replace, at Manufacturers option, defective parts or materials for a period of (90) days from date of original installation and start-up or (12) months from date of shipment, whichever occurs first. All labor costs subject hereto shall be performed during standard work hours at straight time rates.

All warranty claims that include labor requires pre-approval by Halton. Halton, at its discretion, will authorize field warranty work through its own service network or certified third party. No claims for labor charges will be approved for payment if work commences without prior authorization by Halton.

Purchaser shall pay incurred premium labor charge, including overtime, weekends and holidays. Travel time, service charges, miscellaneous tools, material charges, and labor charges resulting from inaccessibility of equipment will not be paid by Manufacturer.

This LIMITED WARRANTY SHALL APPLY ONLY to products that have been installed and maintained in accordance with the installation and Care Instruction Manuals. Purchaser shall be solely responsible for adhering to the instructions and procedures set forth in the said instruction manuals.

This LIMITED WARRANTY SHALL NOT BE APPLICABLE to any damage or defect resulting from fire, flood, freezing or any Act of God, abuse, misuse, accident, neglect or failure to adhere to all instructions set forth in the installation and Care Instruction Manuals. Furthermore, this limited warranty shall not apply to any product that has been altered, unless such alteration has been approved in writing by a duly authorized representative of the manufacturer. In no event shall the manufacturer be liable for any loss, expense, personal injury or consequential damage, of any kind or character, as may result from a defect in material, and/or workmanship, however caused.

EXCEPT AS IS EXPRESSLY SET FORTH IN THIS LIMITED WARRANTY, MANUFACTURER MAKES NO WARRANTY OF MARKETABILITY FOR FITNESS OR ANY PARTICULAR PURPOSE. NEITHER DOES MANUFACTURER MAKE ANY WARRANTY, EXPRESSED OR IMPLIED, WITH RESPECT TO PRODUCTS SOLD BY MANUFACTURER OR AS TO THE USE THEREOF.

Continuous product improvement is a Halton policy, therefore specifications and design are subject to change without notice.

---

## Halton Company

101 Industrial Drive, Scottsville, KY 42164, USA  
Phone 270 237 5600 | Fax 270 237 5700  
Website: [www.halton.com](http://www.halton.com)

## Halton Indoor Climate Systems, Ltd.

1021 Brevik Place, Mississauga, ON L4W 3R7, Canada  
Phone 905 624 0301 | Fax 905 624 0301

The logo for Halton, featuring the word "Halton" in a bold, blue, sans-serif font.