

KBD

Exhaust Hood Balancing Damper

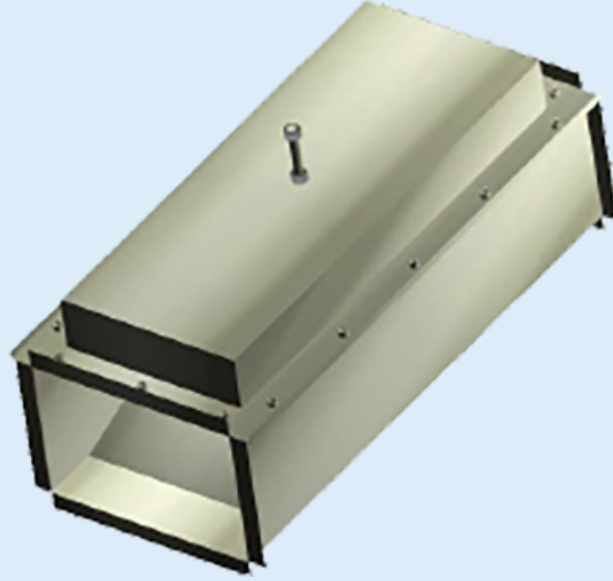

- Accurate airflow balancing for multiple hoods connected to a common exhaust duct.
- Ability to balance each hood to the required exhaust airflow rate.
- Unique design has an adjustable mechanism allowing airflow balance to be easily achieved.
- Meets NFPA and UL qualifications
- Enables duct work to be cleaned using the unit as an access panel.
- Design provides a venturi effect which greatly reduces aerodynamic noise.

The KBD Equalizer™ balancing damper allows for multiple hoods connecting to a common exhaust duct to be balanced both accurately and simply while ensuring the proper exhaust airflow for capture and containment of cooking effluent for each hood section.

Airflow can be determined by turning the adjustment rod and monitoring the differential pressure reading until desired airflow and velocity is achieved. The Equalizer™ can be installed from a vertical position to fifteen degrees off the horizontal position to accommodate the particular installation requirements of the kitchen structure.

Product Models & Accessories

- KBD - Equalizer™ exhaust balancing damper includes access panel that enables duct work for cleaning.
- Calibration curves

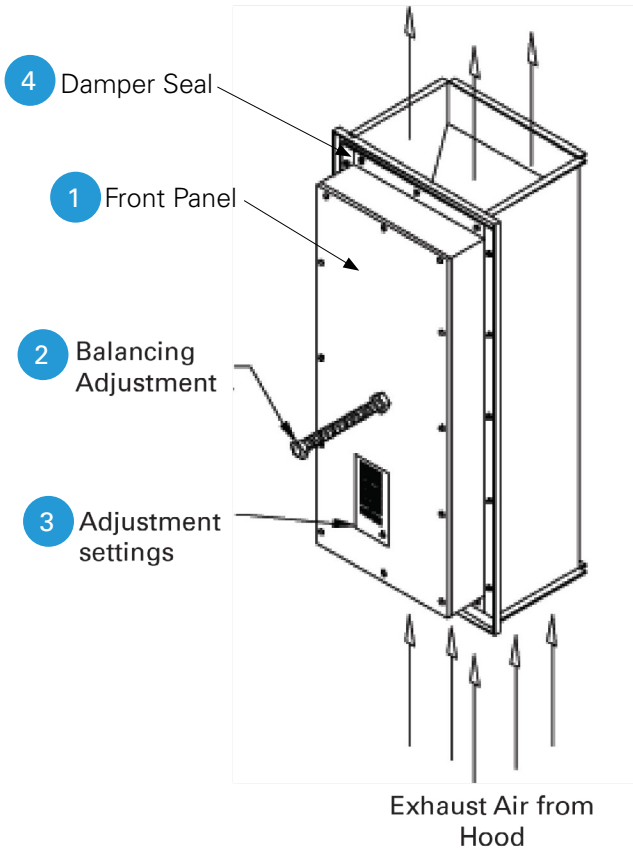

Part		Description
Front panel	1	16 ga. Galvanized Steel
Balance Adjustment Knob	2	Easily adjusts the airflow
Adjustment Setting Chart	3	Calibration Chart
Damper Access Panel Seal	4	Liquid tight rubber seal

Product options

- Calibration curve will be supplied when used with hoods that are not equipped with T.A.B. balancing ports.
- Duct connection sizes

Dimensions

Top View

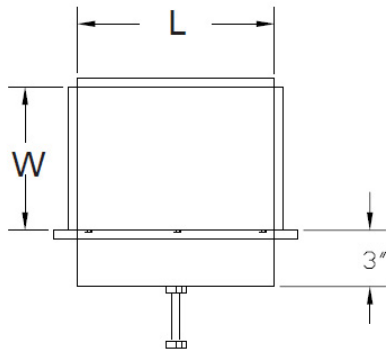

Side View

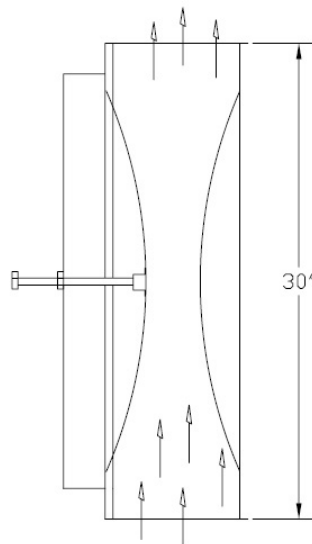

KBD	Inches
Width	8" ... 14"
Length	8" ... 36"
Height	30"
Weight	50 lbs ... 70 lbs

Installation

Install the damper setting the unit on top of the exhaust duct of the hood. The Equalizer™ KBD damper has a 1" flange around the perimeter of the unit, this should line up with the exhaust collar of the hood. Ensure that the damper is welded continuously so that both flanges are liquid tight.

The KBD should be installed in the duct work taking into account the safety distances outlined in the installation guidelines. The damper should be welded assuring that the flange connecting duct work is liquid tight. Note that the damper and housing are universal. Each end of the damper can be used for connections to the collar or duct work depending on the installation site. The Equalizer™ can be installed in either vertical or within 15° of horizontal position (as represented in reference below).

Duct installation - options

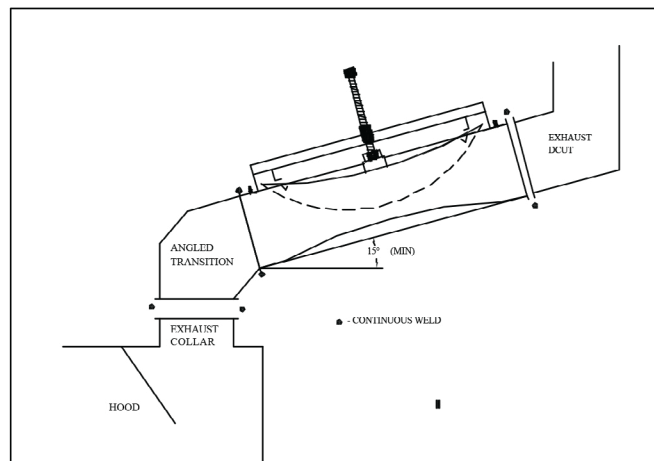
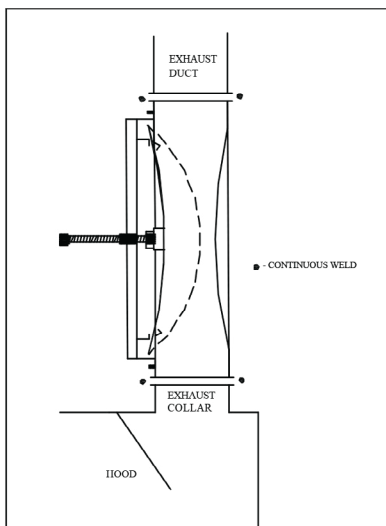
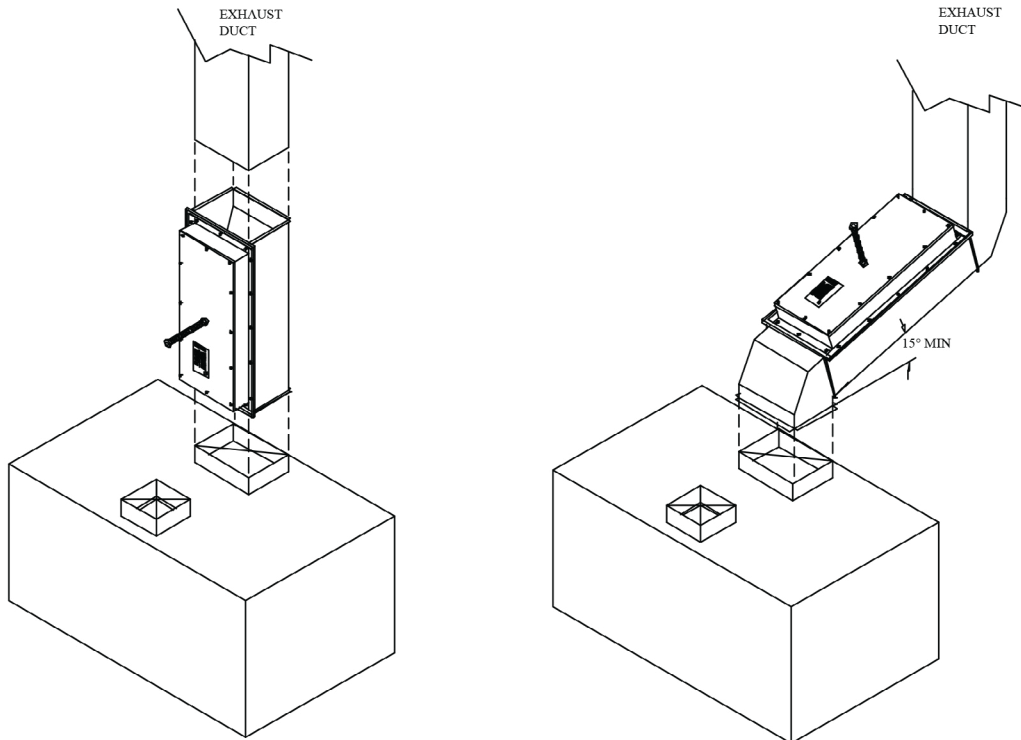

Installation - examples

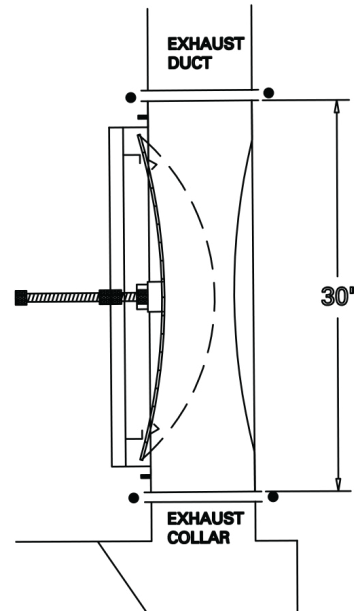
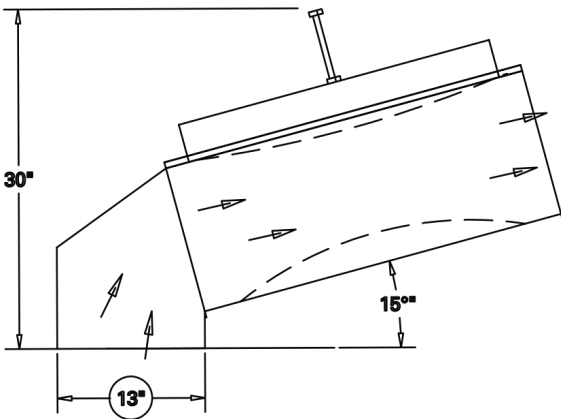
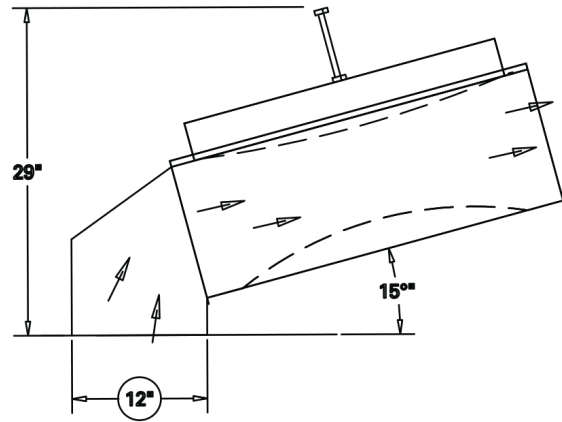
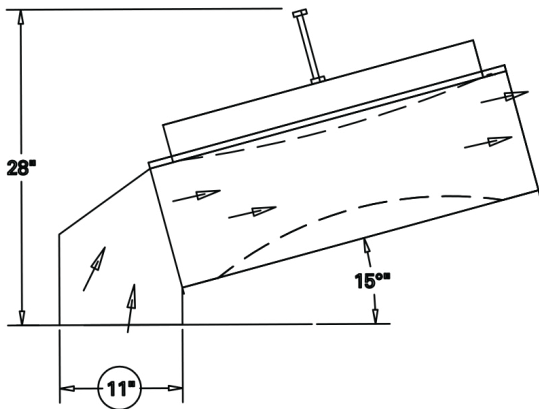
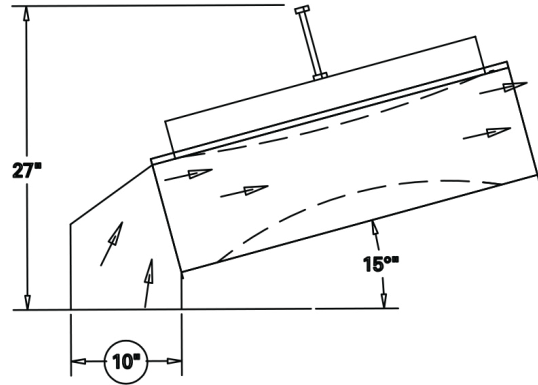
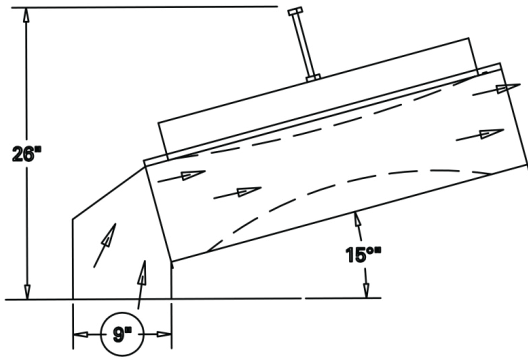

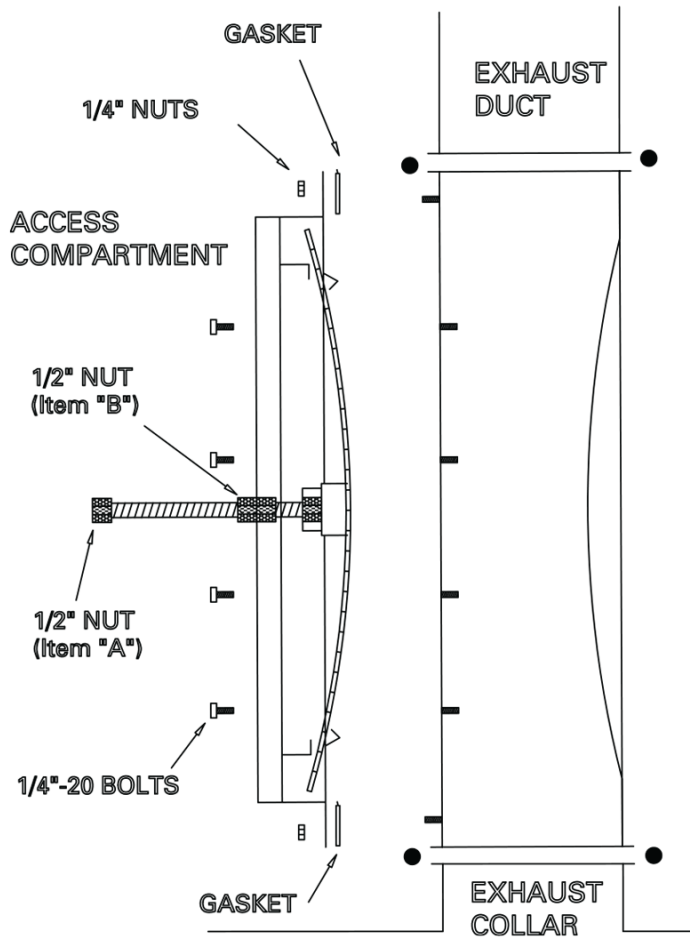

ACCESS COMPARTMENT

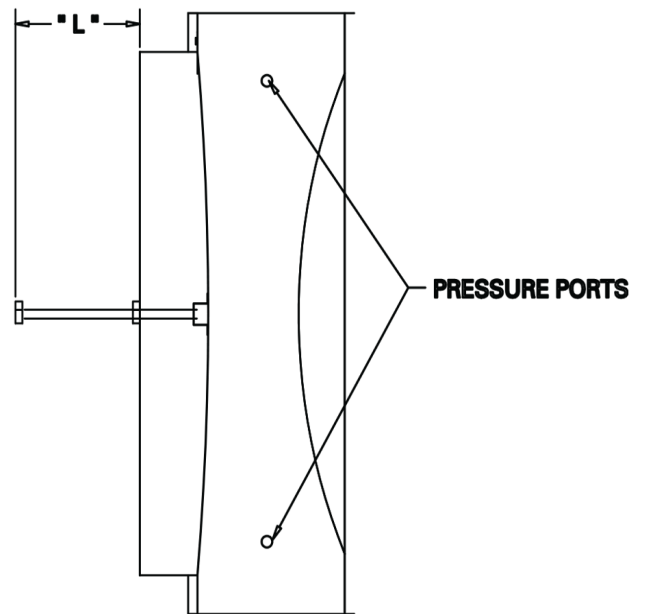
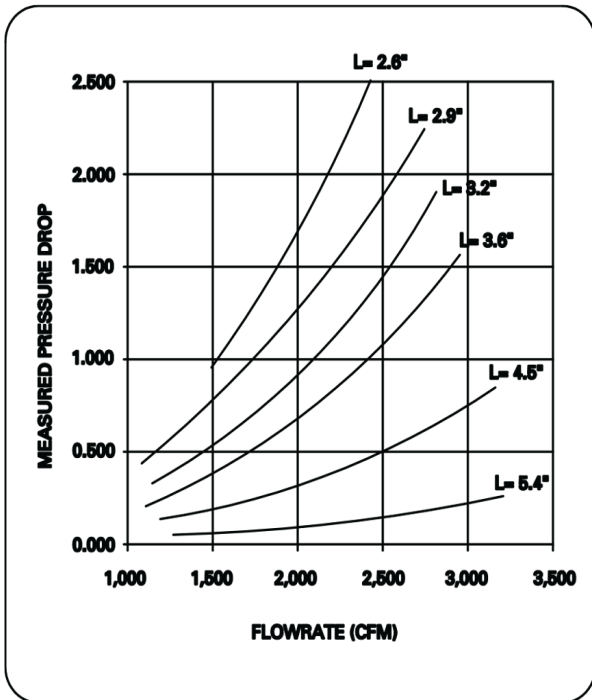
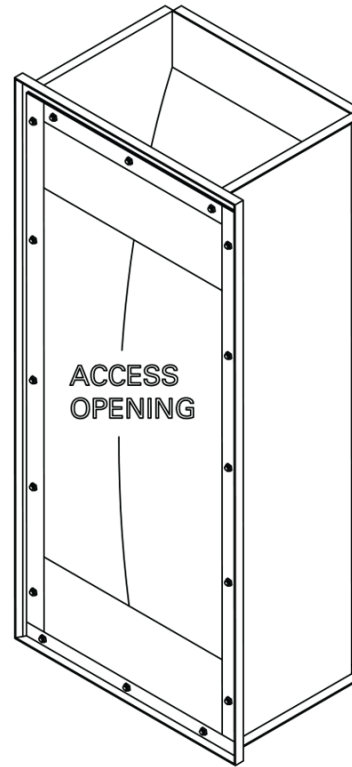

Adjustment

Using the adjustment rod simply turn and monitor the differential pressure reading until desired airflow position is achieved.

The airflow is estimated from the measurement calibration chart using the damper adjustment position and pressure drop across the measurement taps as inputs. The calibration chart is located on the front face of the KBD damper.

Servicing

Cleaning of the duct work is accessible through the front access compartment. Remove the 1/4" nuts and bolts located around the front face of the unit, and then carefully remove the access compartment.

The inside of the duct is now exposed. Clean duct accordingly and carefully re-install the access compartment panel, making sure that the gasket around the perimeter of the front face is still intact. Tighten nuts and bolts to 10 ft. lbs. of torque.

The damper can be adjusted by first loosening the Adjustment rod counter clock wise, opening the balancing panels, turning the rod clockwise will close the balancing panels. Using the calibration curves balance the unit according.

Suggested specifications

The exhaust balancing damper shall comprise an adjustment regulator control rod and airflow calibration settings chart located on the front face of the unit.

The outer frame casing and front panel shall be manufactured of galvanized steel.

The curved balancing panels shall be constructed of 18 ga. stainless steel. One curve shall be a fixed position panel, while the operable panel shall be adjustable using the balancing adjustment rod extended from the front face of the damper.

The balancing damper shall be UL listed per standard 710 and be fabricated in compliance with NFPA-96.

The company has a policy of continuous product development, therefore we reserve the right to modify design and specifications without notice.

For more information, please contact your nearest Halton agency. To find it: www.halton.com