

USM MARINE EXTERNAL LOUVRE

For air intake and exhaust



MATERIALS

PART	MATERIAL	FINISHING	NOTE
Fixed blades	Steel	Painted*	Blade material thickness is 1.0 mm
Fixed blades	Stainless steel EN 1.4404 (AISI 316L)	-	-
Fixed blades	Aluminium EN AW 5754/ EN 6060	Painted*	-
Frame	Steel	Painted*	Frame material thickness is 3.0 mm as standard
Frame	Stainless steel EN 1.4404 (AISI 316L)	-	-
Frame	Aluminium EN AW 5754	Painted*	-
Mesh	Stainless steel EN 1.4404 (AISI 316L)	-	Mesh opening is 12.7 mm

*Painted RAL9010, C3 as standard. C3 average service life 7-15 years. C5 with average service life of 15-25 years available as an option.

USM PRODUCT OPTIONS

- Modular construction is available for larger sizes
- A mesh fitted behind the louvre is available as an option
- Non-standard dimensions and flange drilling are available as an option

APPLICATIONS

The Halton USM marine external louvre can function as either a primary air intake device or an exhaust air diverter.

These louvres are commonly installed in engine/machine rooms and HVAC equipment rooms to facilitate air control.

FEATURES

- External louvre designed for both air intake and exhaust
- The louvre effectively prevents rainwater, snow, leaves, animals, and other objects from entering the ductwork
- Its performance is achieved through a unique front-edge blade profile and side grooves
- Suitable for applications with medium and high airflow rates
- The blades have a depth of 70 mm, are spaced 50 mm apart, and provide a 50% free opening

GENERAL USM DRAWINGS

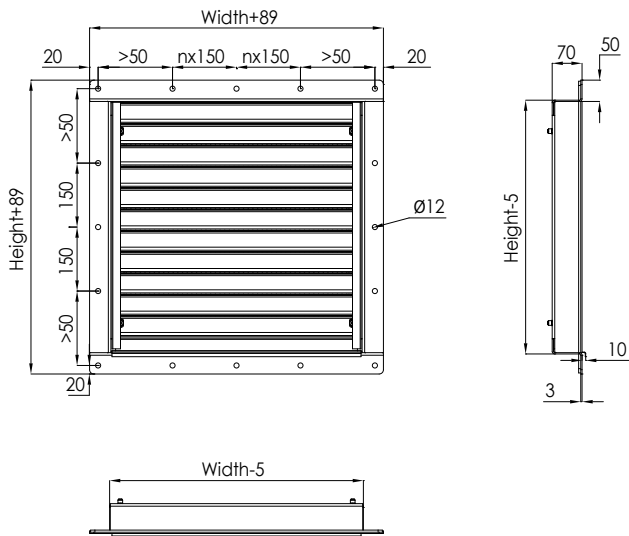

USM CONSTRUCTION

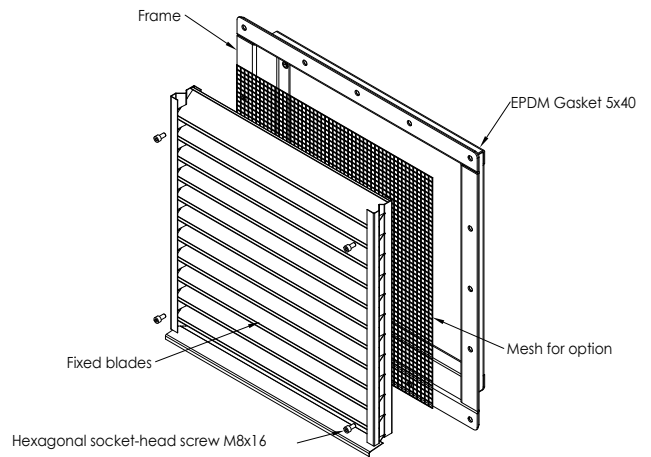

USM FUNCTION

Air is supplied or extracted through the horizontal blades. The design of the grille prevents rainwater from reaching the ductwork. The slot between the frame and the top blade is sealed, ensuring rainwater doesn't enter the ductwork from above. Drops of water are collected in the grooves at the front edge of the blades, and water flows into the side grooves, where it is directed downward.

USM DIMENSIONS

The USM louvres are manufactured for rectangular openings with widths (B) ranging from 150 to 1500 mm and heights (H) from 150 to 2400 mm, with a 1 mm division. Modular construction is available for larger sizes. Special flange configurations are available on request.

TRADITIONAL OUTDOOR LOUVRE

Rain falling on the vane flows downwards to the front edge of the vane. Drops formed at the edge fall onto the vane below and, upon contact with the vane surface, break into small droplets and spray that can be easily carried by the airflow through the louver. Water flowing along the wall onto the louver can penetrate the slot between the frame and the top vane unless the slot has been closed.

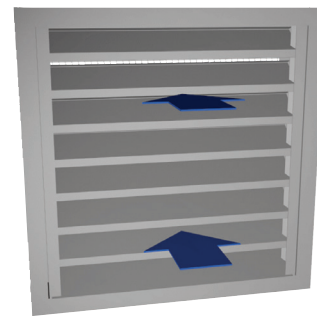

USM BLADE CONSTRUCTION

The vanes of the USM louver are specifically designed to collect water droplets in grooves at the front edge of the vanes. Once the slot between the frame and the top vane is securely closed, water flowing down the wall will not enter the louver. The top vane guides the water to the side grooves, where it then flows downward alongside the airflow.

