

DSA – Droplet separator with heating



Overview

- High droplet and moisture separation efficiency
 - Class A results (EN 13030:2001)
 - Minimum pressure drop
- Performance tested according to EN 13030:2001 test for louvres subjected to simulated rain, at the independent laboratory
- Tailored sizes and designs according to customer's needs. Modular construction is available.
- For wall and duct installations
- No special maintenance required
- ATEX certified components II 2 G/D EEx e II T3/T2
- Heating capacity 2,5 kW/m² – 3,7kW/m²
- Operating temperature for DSA -50 °C – +40 °C
- An Extreme Conditions Solution available
- Stainless steel junction box available as an option

Specification

DSA droplet separators are fitted with heating elements. The regulated temperature is subject to the surrounding conditions. The actual surface temperature of the heated DSA depends on many variables such as the size of the separator, wind circumstances, face velocity, air temperature and relative humidity. Electrical heating capacities vary between 2,5 kW/m² – 3,7 kW/m², depending on these conditions. The cable heating does not prevent icing in the most severe conditions, but it will help defrost the ice when the icing conditions have passed.

When intake air is crucial during extreme icing conditions the Halton ECS (Extreme Conditions Solution) keeps the air intake open. The ECS is available as an option.

Dimensions

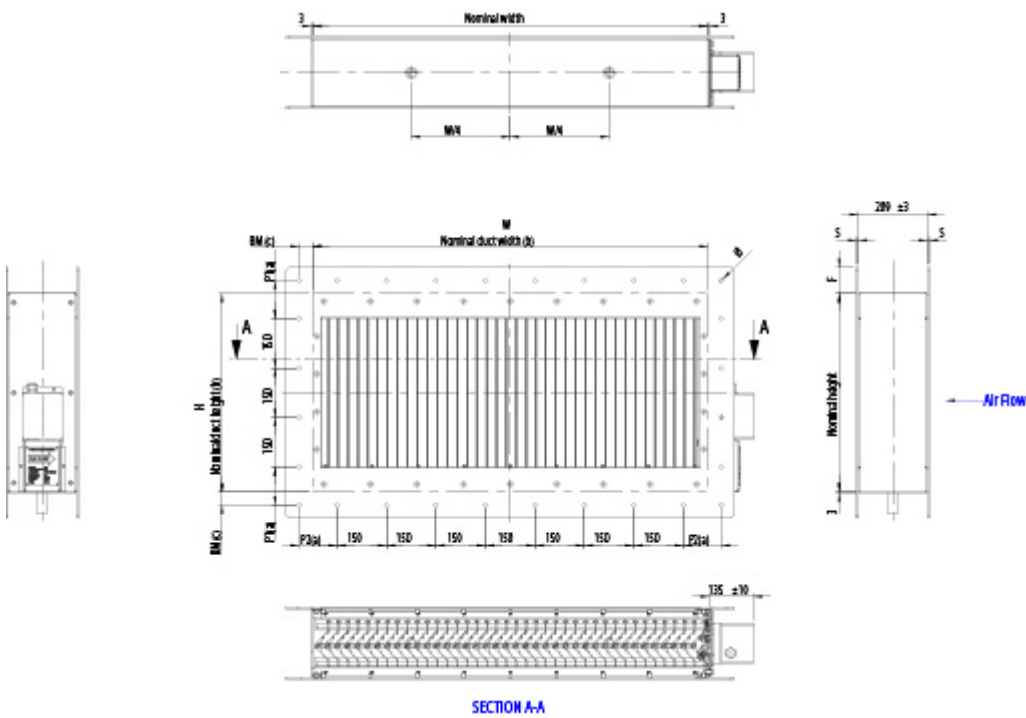

Please note

1. $75 \text{ mm} < P1 \ \& \ P2 < 150 \text{ mm}$
2. Width x Height = nominal duct size (internal)
3. Back mark BM is the distance from the inside duct to centerline hole

Frame options

- Flange only in front
- Flange only in back
- Flange in front and back
- Without a flange

Flange drilling ISO15138 as standard.

Nominal duct Longest side (mm)	Back mark BM (mm)	Flange F (mm)	Bolt hole size \varnothing (mm)	Aluminium Flange thickness S (mm)	Stainless steel Flange thickness S (mm)
≤ 350	20	40	10	5	3
$> 350 \text{ to } \geq 1000$	30	50	12	5	3
> 1000	40	80	14	5	5

Minimum and maximum dimensions

A minimum size for Halton DSA droplet separator is 300×300 mm (W×H). Maximum size for a single separator is 1500×1200 mm (W×H). Sizes with 50 mm divisions. Modular construction available up to 3000×2400 mm (W×H).

Material thickness

Standard frame thickness 3 mm. Larger thicknesses available as an option.

Material and Finishing

PART	MATERIAL	FISHING
Droplet separator	Aluminium EN AW 6060	–
Frame	Aluminium EN AW 5754	Painted RAL9010, C3 acc. standard* ISO 12944-2 as standard
Frame	Stainless steel EN 1.4404 (AISI 316L)	Painted as an option
Heating cable	Nickel-plated copper wire, silicone rubber outer jacket (ATEX certified)	–
Junction box	GRP, Eex e II T6 IP66	–

*) C3 durability of 7-15 years. Please note about painting procedures; NORSOK C5-M and Norsok M501 available on request. Please note: Stainless steel junction box available as an option.

Electrical Data and Control

Power supply 230V, 1 Phase AC.

Electrical heating capacities vary between 2,5 kW/m² – 3,7 kW/m², depending on ambient temperature. For optimal performance and control, contact Halton Marine.

Drainage

Drain pipe

Threaded drain pipes are welded to the bottom of the droplet separator. The thread type is 1" BSPT (male).

Drain locations

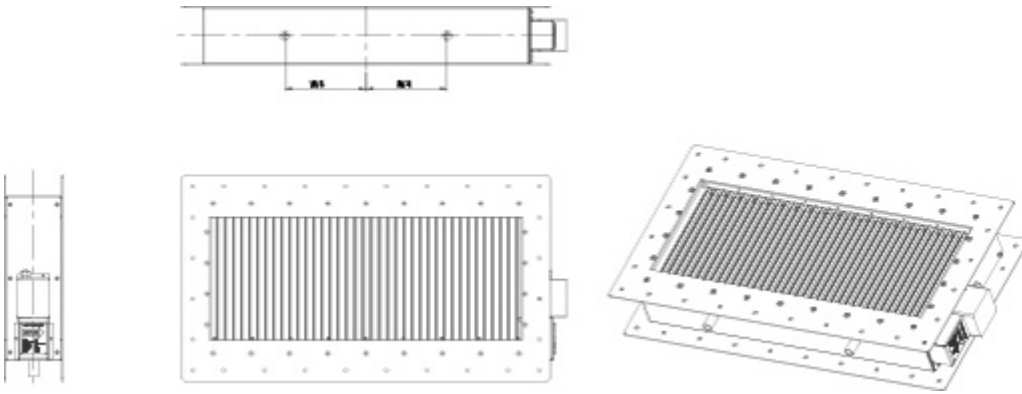

Drain pipe sizes

Weld-on pipe	Ø (Inch)	L (mm)	A (mm)	d1 (mm)	d2 (mm)
Aluminium EN AW 6060	1	50	25	25	35
Stainless steel EN 1.4404 (AISI 316)	1	40	20	27	34

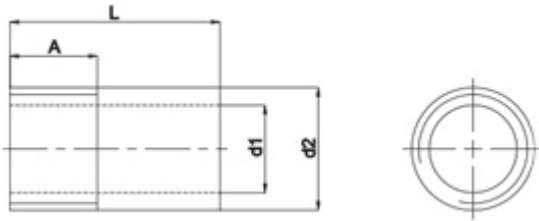

Optional Features

The Extreme Conditions Solution (ECS)

When intake air is crucial during extreme icing conditions, the Halton Extreme Condition Solution (ECS) keeps the air intake open. The Halton ECS combines the DSA heated droplet separators with either shut-off or fire dampers with an additional option for filter units.

The solution can allow one or more separators to remain open and ice-free while the other separator is in defrost mode during critical atmospheric conditions.

This is achieved by shutting-off a section of the DSA to allow the ice build-up to melt.

There are a few control methods available to alternate the opening/closing sequence of the ECS to ensure a free flow of unrestricted air.



“Gooseneck” – Reducing the wind effect

Strong wind can adversely affect the performance of the droplet separator. In environments where stormy weather is regular Halton recommends using a “gooseneck” air intake with droplet separators. A gooseneck can be installed directly to a duct installation type of droplet separator.

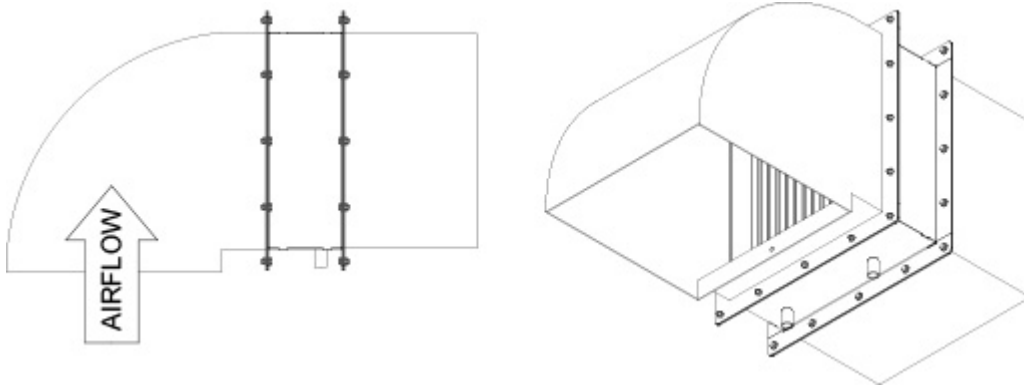

Filters

Please note: filters installed in DSA require always a separate frame.

ISO Coarse 70% filter

Panel filters are manufactured of progressive thermally smoothed synthetic polyester having high dust holding capacity and constancy for humidity. The filters are used in general ventilation system for air purification.

ePM10 70%, ePM2,5 65%, ePM1 50% Bag filters

The materials of the synthetic fine filters are high-quality and durable, progressive mounted synthetic fibres. The filters can be used in example for air purification of intake air.

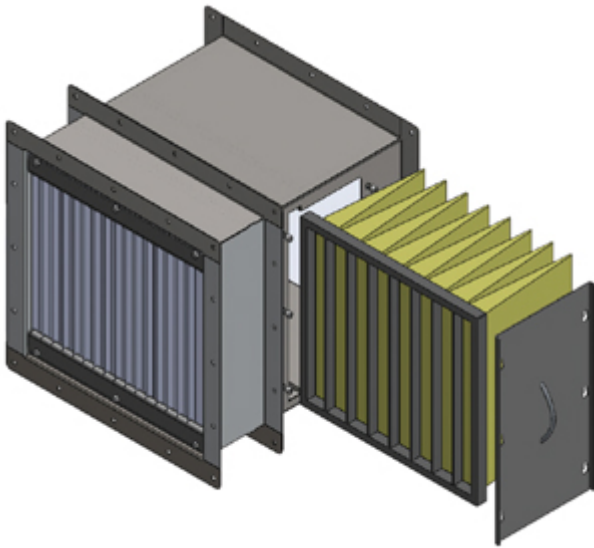

ATEX approved filters

Halton Marine also offers ATEX approved filters for droplet separators.

Installation in conjunction with damper

Halton droplet separator can be connected to a Halton Marine damper with or without a connection piece. In both cases the construction is modified to fit the damper. Connecting DSH together with a fire damper must be mentioned when ordering products. Special flanges and drilling patterns are available for all models on request. The structural flexibility of dampers and high-quality combined with a wide range of accessories (ex-actuators) and special steels, enable Halton Marine to offer tailored solutions for its customers.

Combining Halton Marine droplet separator to damper offers customers a compact solution for air intake that also saves space. The products are recommended to be connected together at Halton Marine factory.

Weather tight hatch

Weather tight hatch (WTH) is used e.g. to shut down the intake close to the waterline in the event of rough seas. See a separate brochure on weather tight hatch called Halton WTH.



Results

Pressure drop and sound data LPA[DB(A)]

DSA aluminium, pitch spacing 28 mm. Velocity based on face area

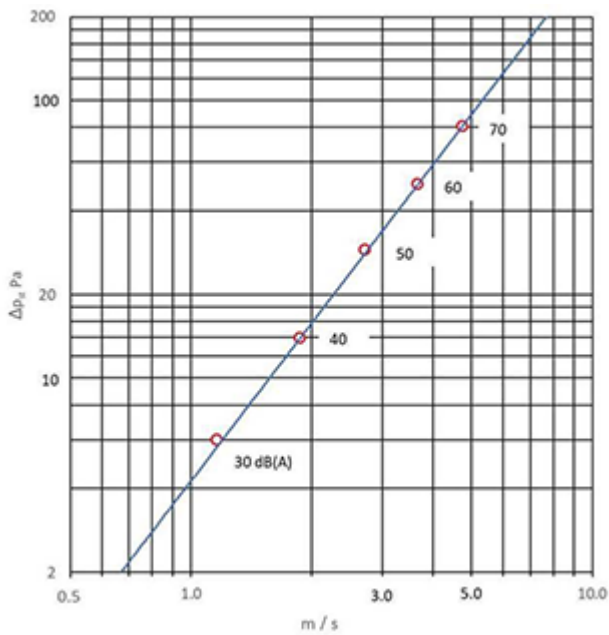

DSA efficiency results

Single stage DSA, pitch spacing 28 mm

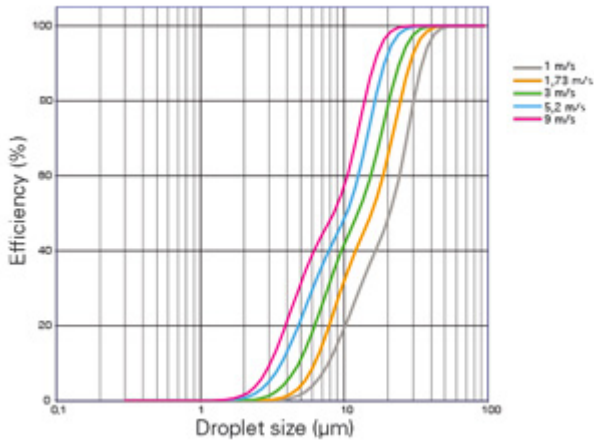

Performance data

Effectiveness for removal of simulated rain
 EN 13030:2001
 Rainfall rate: 75 (l/h)/m², (75 mm/h)
 Vertical installation

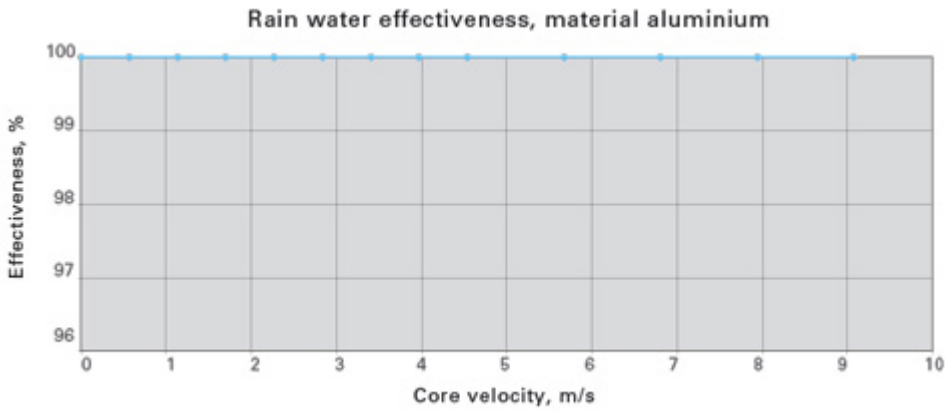

Weights

Weights of DSA including frame, 1 flange, aluminium (KG), pitch spacing 28 mm

H/ HEIGHT mm	300	350	400	450	500	550	600	650	700	750	800	850
300	10	12	13	14	16	17	18	20	21	22	23	24
350	12	13	14	16	17	19	20	22	23	24	26	27
400	13	14	16	17	19	20	22	24	25	27	28	30
450	14	16	17	19	21	22	24	26	27	29	31	32
500	15	17	18	20	23	24	26	28	29	32	34	35
550	16	18	20	22	24	26	28	30	32	34	36	38
600	17	20	21	24	26	27	30	32	34	36	39	40
650	18	21	22	25	28	29	32	34	36	39	41	43
700	19	22	24	27	29	31	34	37	38	41	44	45
750	21	23	25	28	31	33	36	39	40	43	46	48
800	22	25	27	30	33	35	38	41	43	46	49	51
850	23	26	28	31	34	36	40	43	45	48	51	53
900	24	27	29	33	36	38	42	45	47	51	54	56
950	25	29	31	34	38	40	44	47	49	53	56	59
1000	26	30	32	36	40	42	46	49	52	55	59	61
1050	29	33	35	39	43	46	50	54	56	60	64	66
1100	30	34	37	41	45	47	52	56	58	62	66	69
1150	31	36	38	42	47	49	54	58	60	65	69	72
1200	32	37	40	44	48	51	56	60	63	67	72	74

The weights on the table are indicative and do not include a filter and damper.

Consult Halton Marine for weights for different types of configurations and weights for modular constructions.

A minimum size for Halton DSA droplet separator is 300×300 mm (W×H). Maximum size for a single separator is 1500×1200 mm (W×H). Sizes with 50 mm divisions. Modular construction available up to 3000×2300 mm (W×H).

Product code

(S)=Model

(A) Single W1H1

(B) Side by side W2H2

(C) One on the other W1H2

(D) Two by two W2H2

(W)=Width

300-1500 mm per module, max 2×2 modules

(H)=Height

300-1200 mm per module, max 2×2 modules

Specifics and accessories

(MP)=Module

(M1) Left upper module

(M1) Left upper module

(M2) Right upper module

(M3) Left lower module

(FM)=Frame Material

(AS) Stainless steel (EN 1.4404)

(LS) Stainless steel (EN 1.4432)

(AL) Aluminium EN AW 5754 (RAL9010 default paint)

(SM)=Separator Material

(AS) Stainless steel (EN 1.4404)

(AL) Aluminium EN AW 6060

(FT)=Frame type

(FD) Flange both sides (double)

(FF) Flange in front (front)

(FB) Flange in back (back)

(EX)=Safe area

(N) No

(Y) Yes

(ZT)=ETO Processing

(Y) Yes

(N) No

AC=Accessories

(MD) Manometric drain trap

Code example

DSA/A-300-300,MP=M1,FM=AL,SM=AL,FT=FD,EX=Y,ZT=N,AC=MD