

# KFM – Galley grease hood



## Features

- The design follows USPHS guidelines
- Easily removable filters for cleaning
- High level of hygiene facilitated
- Prevention of the build-up of grease deposits, which pose a serious fire hazard
- With Halton Capture Jet™ technology reducing the required exhaust airflow rate and improving the capture and containment efficiencies of the hood, while reducing energy use
- High-efficiency grease filtration using Halton KSA multi-cyclone filters
- Supplied as standard with lighting, balancing dampers for both capture and exhaust air and T.A.B.™ airflow measurement taps, which allow accurate and effective balancing of airflows, and efficient commissioning
- Stainless steel welded construction
- High-efficiency grease filtration using Halton KSA multi-cyclone filters

## Specification

Halton KFM is a galley grease hood for use in marine & offshore applications to remove contaminated air released by cooking equipment. The KFM hood uses Halton Capture Jet™ technology, which allows the hood to operate with up to 30% lower exhaust airflow rates than traditional hoods.

# Dimensions

## KFM general drawings

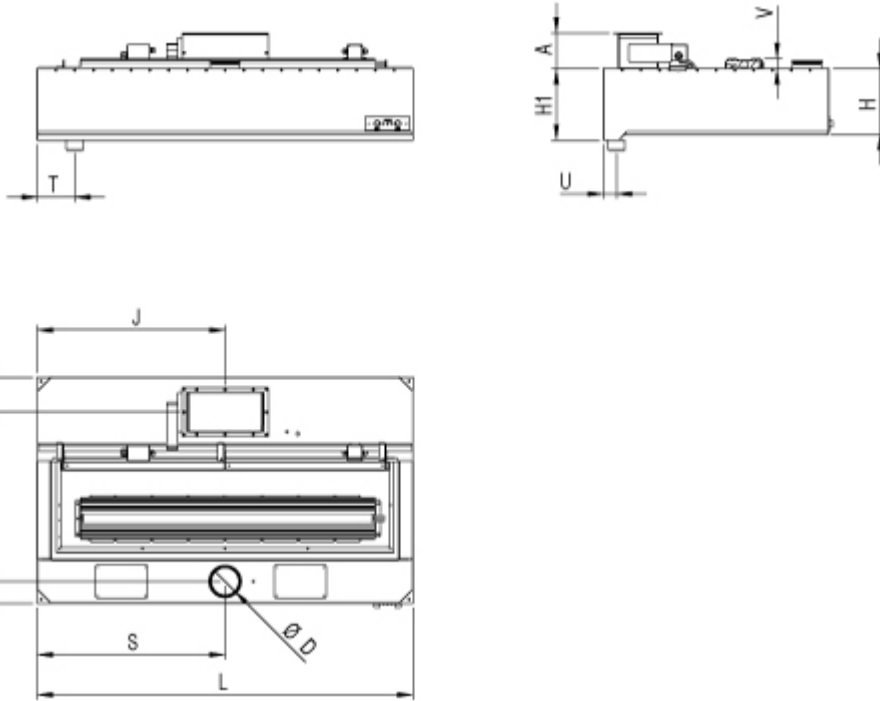

### KFM DIMENSIONS (mm)

A	195
B	1100-1900
C	115
D	100-200
H	350
H1	380
J	1/2L
L	1000-3000
P	185
S	1/2L
T	200
U	70
V	Max 50

Note: Maintenance / light fixture hatch is as big as the construction allows.

# Material

PART	MATERIAL	THICKNESS	NOTE
Main body	Stainless steel EN 1.4301 (AISI304)	1,25 mm	Option: EN 1.4404 (AISI316L)
Light fixture	Painted steel	–	–
Cables	Halogen free	–	–

# Construction

The KFM hood comprises a Capture Jet™ air supply module, a light fixture, adjustment dampers, airflow measurement taps and KSA grease filters. All parts of the hood are manufactured from polished stainless steel EN 1.4301 (AISI304). The Capture Jet™ supply plenum is thermally insulated through the use of mineral wool material to prevent condensation on the inner face above the cooking equipment. The hood is equipped with removable grease cup for collection of the grease.

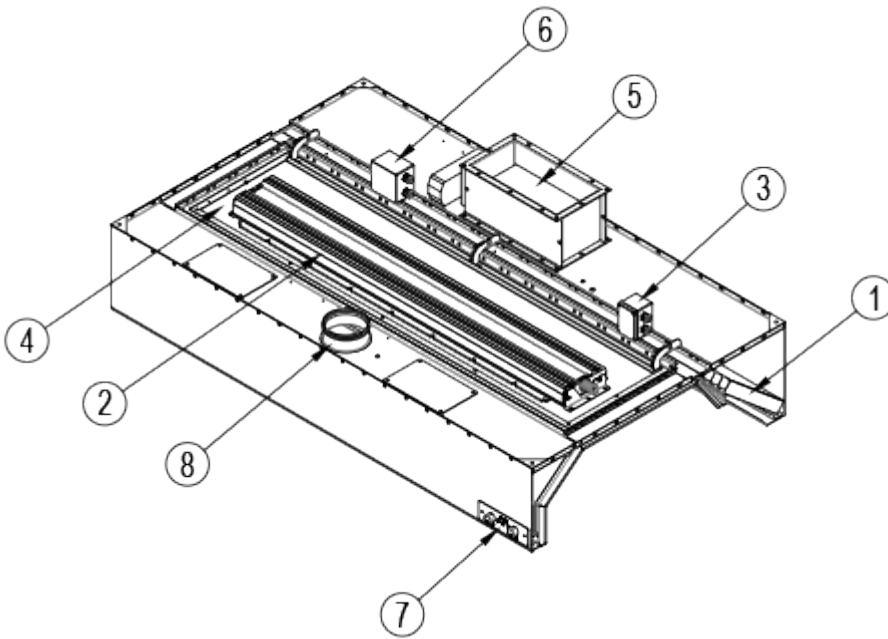

## PARTS

1. KSA grease filters
2. Lighting fixture
3. Lighting fixture power supply junction box
4. Maintenance hatch
5. Exhaust air connection, fire damper or shut-off damper\* (available as an option) and adjustment damper
6. Fire damper junction box (available as an option)
7. Damper switch and indication (available as an option)
8. Capture air connection and adjustment damper

\*If fire or shut-off damper is located at the duct, Halton suggests two default solutions for duct connection:

- Eurovent-collar with flange
- Welded L-collar

### Eurovent-collar with flange

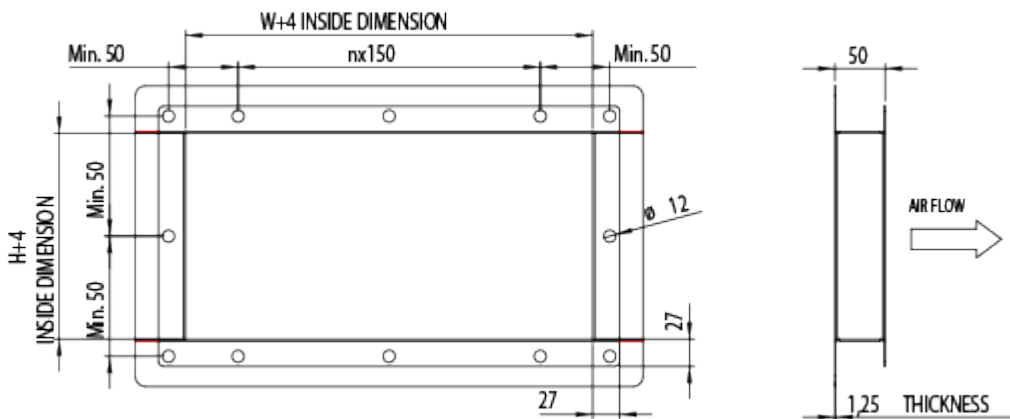

\*Drilling pattern according to Eurovent

## Welded L-collar

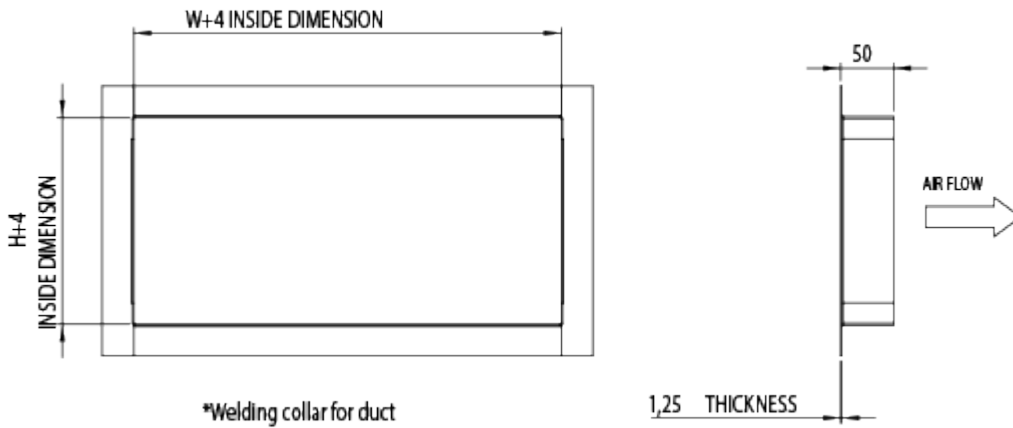

## Weights of standard KFM hoods (kg)

B/L	1000	1500	2000	2500	3000
1100	40	60	80	100	110
1300	46	66	86	106	118
1500	51	71	92	111	126
1700	57	77	98	117	134
1900	63	83	103	123	142

The above table represents an indication of different size of average KFM hoods without Capture Jet technology. Weight does not include the fire damper.

## Weights of standard KFM hoods with Capture Jet Technology (kg)

B/L	1000	1500	2000	2500	3000
1100	50	74	100	124	138
1300	56	80	105	129	146
1500	61	86	111	135	154
1700	67	92	117	141	162
1900	73	97	122	147	170

The above table represents an indication of different size of average KFM hoods with Capture Jet technology. Weight does not include fire damper.

# Function

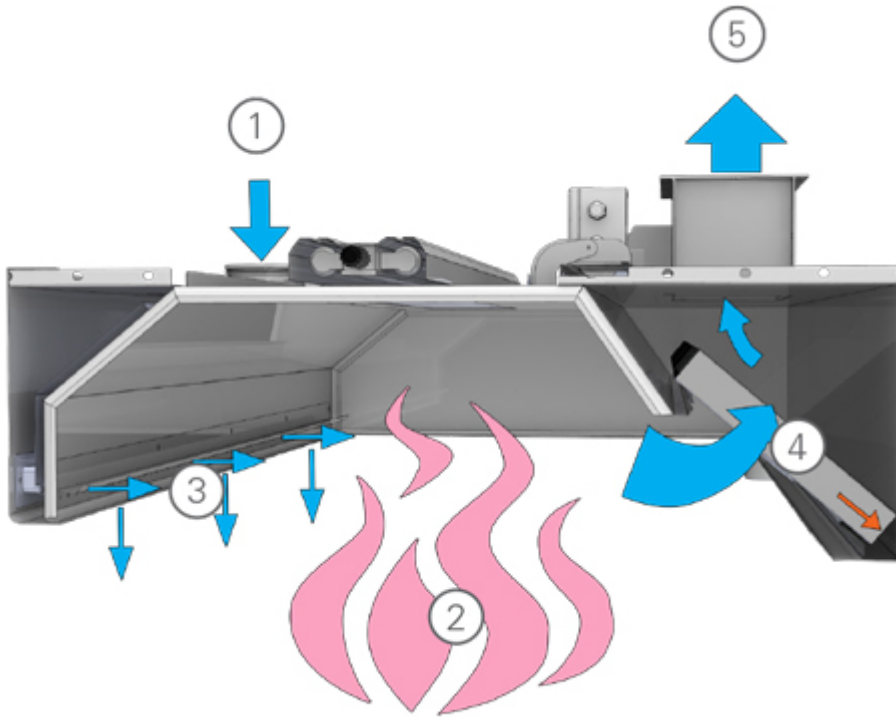

1. Supply air enters the Capture Jet™ plenum.
2. Contaminated air and heat rises from the cooking appliances.
3. Contaminated air is directed into the hood by Halton patented Capture Jet™ technology.
4. KSA multi-cyclone filters remove grease and contaminants from the air stream with the aid of centrifugal effect. According to independent laboratory tests KSA is the most efficient mechanical grease filter on the market.
5. Filtered exhaust air.

## Recommended exhaust airflow for KFM

RECOMMENDED EXHAUST AIRFLOW				
NUMBER OF KSA FILTERS	MINIMUM l/s	MAXIMUM l/s	MINIMUM m <sup>3</sup> /h	MAXIMUM m <sup>3</sup> /h
1	130	201	468	724
2	259	402	932	1447
3	389	602	1400	2167
4	518	803	1865	2891
5	648	1004	2333	3614
6	778	1205	2801	4338

Note: KSA filter size 500x330x50 mm

# Specifications

## Suggested specification

### General

The galley hoods shall be constructed from stainless steel EN 1.4301 (AISI304). The galley hoods shall be supplied complete with outer casing / main body, airflow measurement taps, exhaust air spigot connection with adjustment damper, maintenance hatch, light fixture, grease filters, grease cup. Classified fire damper in each exhaust connection. Classified fire damper in each exhaust connection is available as an option. The manufacture of all galley hoods shall be controlled by ISO 3834-2:2005, ISO 9001, 14001 and OHSAS 18001 standards. The design of hoods shall follow USPHS guidelines.

### Construction

All parts shall be constructed of stainless steel sheet (thickness 1.25 mm) with a polished finish. The inside corners of the hood are rounded for easy cleanability according to USPHS guidelines. The joints at the lower edges of the device are welded. All visible screws are thumb screw type. The hood is equipped with a grease cup for removing the grease. There is a maintenance hatch in each hood for easy access above the hood.

### Capture Jet plenum

The Capture Jet™ plenum shall be insulated with sealed mineral wool. Plenum can be accessed through a maintenance hatch(es).

### Capture Jet system

The hood shall be designed with Capture Jet™ technology to reduce the exhaust airflow rate required and increase the capture and containment efficiencies of the hood, while reducing energy use.

### Airflow measurement taps

Measurement taps shall be located on top of the hood for supply air and exhaust air measurement.

### Halton KSA filter

- Minimisation of grease deposits in the ducts
- Enhanced hygiene and safety

The KSA grease filters shall be constructed of stainless steel. The grease filters shall be supplied in modular size of 500x330x50 mm and shall be removable via two folding handles. The grease filters shall have a honeycomb design in order to allow high grease filtration efficiency with the aid of centrifugal effect in filter honeycombs.

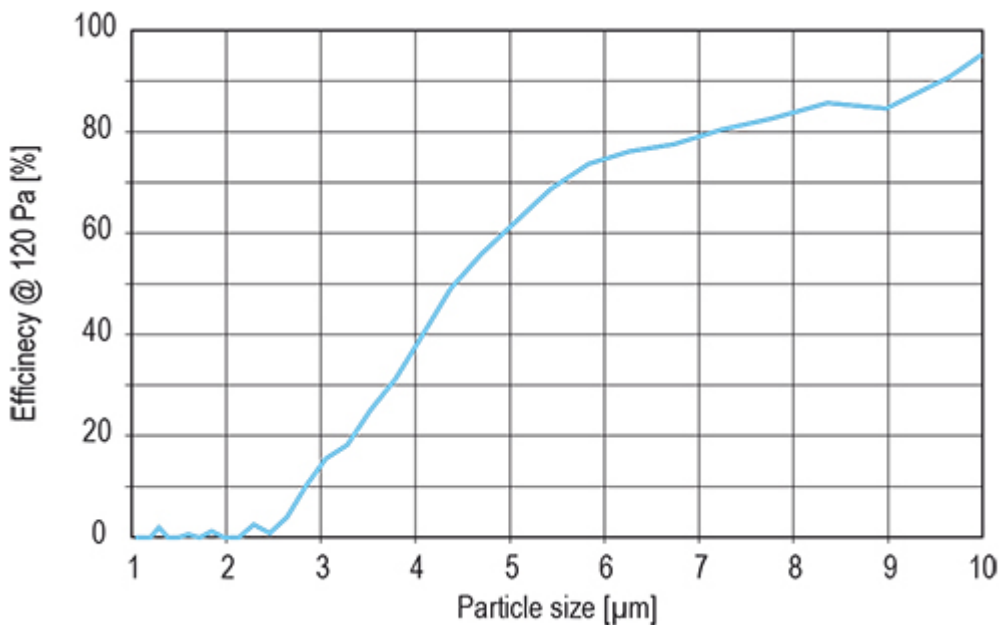

Mechanical filtration is recommended to be used in hoods with low utilization rate and cooking process producing mainly large grease particles (> 8 microns), e.g. food prepared with gas fryers, griddles and broilers (source ASHRAE).

## Duct connections

The duct connections and adjustment dampers for exhaust air shall be constructed from stainless steel. The dampers shall be adjustable.



## Light fixtures

Each hood shall be delivered with a fluorescent light fixtures or LED light fixtures providing approx. an average illuminance of 500 lux at the work surfaces of the cooking appliances. The light fixtures shall be suitable for a single-phase 230-VAC power supply and shall be manufactured to be of protection class IP67. The ballast and capacitor shall be located within the light frame. The core electric cables connecting the light fixture to the junction box shall be provided. The light fixture shall be installed on a hinged maintenance hatch, allowing access to the hood roof.

### Fluorescent light fixture sizes

HOOD DIMENSION	LENGTH	WIDTH
L < 1250 mm, 2×24 W	720 mm	220 mm
L ≥ 1250 mm, < 2000 mm, 2×39 W	1020 mm	220 mm
L ≥ 2000 mm, 2×49 W	1620 mm	220 mm

### LED light fixture sizes

HOOD DIMENSION	LENGTH	WIDTH
L < 1250 mm, 1×28 W	720 mm	175 mm
L ≥ 1250 mm, < 2000 mm, 1×42 W	1020 mm	175 mm
L ≥ 2000 mm, 1×69 W	1620 mm	175 mm

## Maintenance hatch

Each hood shall be provided with a maintenance hatch made of stainless steel with a shock-resistant plastic window. The heat tolerance of the window shall be up to +115 °C. The hatch shall be easily opened and closed. The maintenance / light fixture hatch is as big as the construction allows.

# Airflow measurement

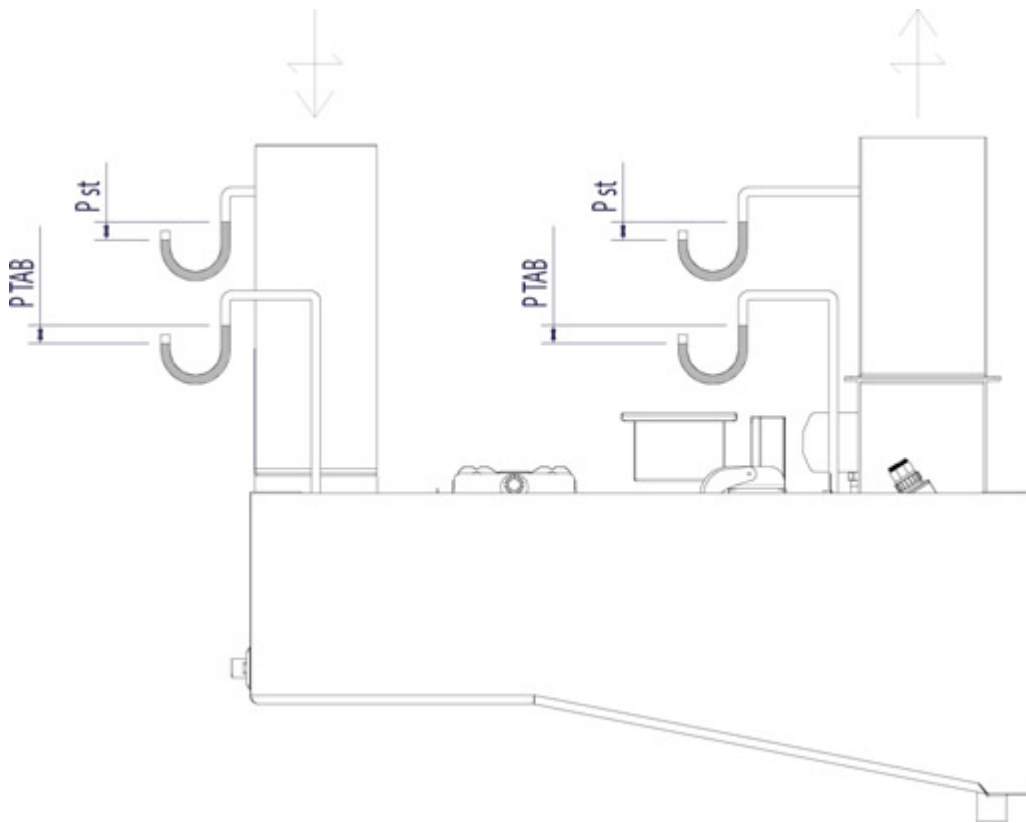

$\Omega P_{st}$  = Static pressure loss

$\Omega P_{TAB}$  = TAB pressure for airflow rate measurement

## Product code

(S)=Model  
(N) With Capture Jet  
(S) Without Capture Jet

(L)=Length  
1000-3000

(W)=Width  
S=N: 1000-2000 S=S: 850-2000  
Model S=N with Capture Jet  
Model S=S without Capture Jet

(H)=Height of front end  
350 mm

(MV)=Marvel  
(N) No  
(A) 1 sensor

- (B) 2 sensors
- (C) 3 sensors
- (D) 4 sensors

- (UB)=UV or MARVEL Box
- (C) Marvel-box PL
- (N) No

- (MA)=Material
- (SS) Stainless steel EN1.4301
- (AS) Stainless steel EN1.4404

- (DS)=Diameter of supply connection
- 100
- 125
- 160
- 180
- 200

- (LF)=Light fixture
- (A) Type SLR
- (B) Type LED SLV

- (FK)=Fire suppression system
- (N) No
- (1) 1 pc
- (2) 2 pcs
- (3) 3 pcs

- (AC)=Accessories
- (BL) Capture Jet fan with potentiometer
- (HE) Ceiling condensation removal heating

Code example

KFM1/N-3000-2000-350,MV=N,UB=N,MA=SS,DS=100,LF=A,FK=1,ZT=Y,AC=BL