

Halton Rex 600 Basic (R6B) – Chilled beam



Overview

- A base version to the combined cooling, heating, and supply air unit for flush installation within a suspended ceiling.
- Well suited for spaces where demand based ventilation, individual control and flexibility are not required.
- Making effective site logistics possible.

Typical applications: office rooms and landscape offices.

Product models and accessories

- Model with combined cooling and heating exchanger

Dimensions

Total lengths 1200, 1800 and 2400 mm

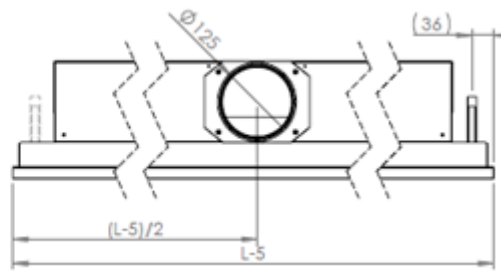
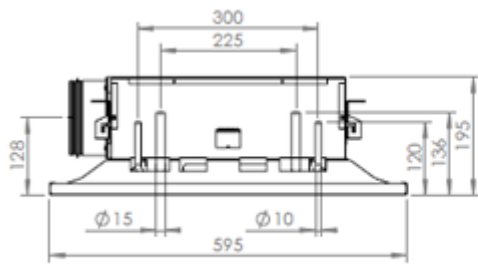

Total length 3000 mm

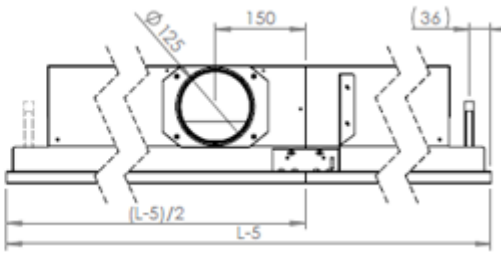
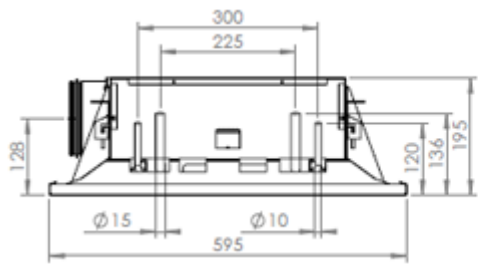

ØD	125
Coil length	1000, 1600, 2200, 2800
L-5	1195, 1795, 2397, 2995
kg/m	14

Integration with suspended ceiling

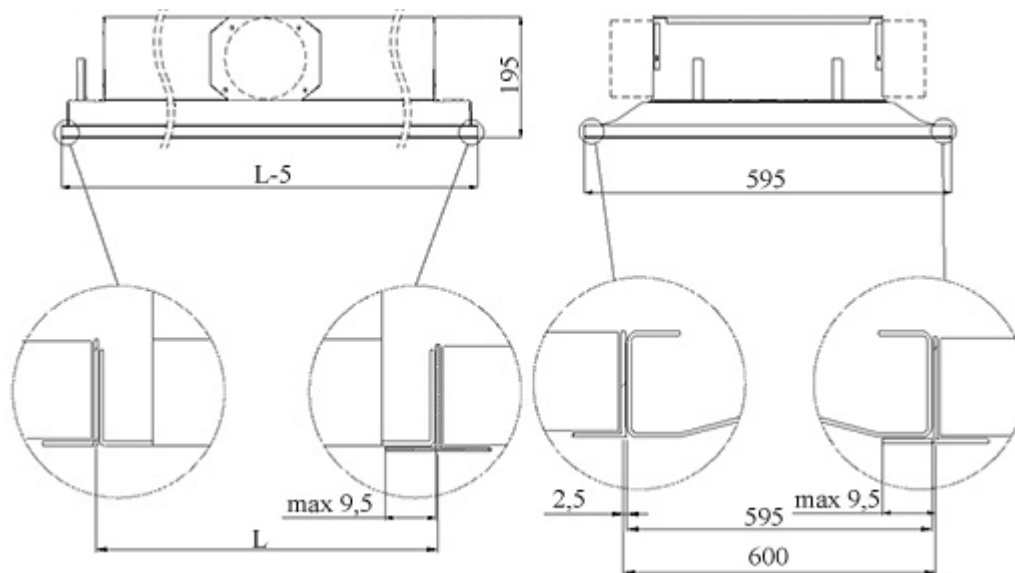

Material

Part	Material	Finishing	Note
Front panel	Pre-painted galvanised steel	Polyester – painted white (RAL 9003 or RAL 9010, 20% gloss)	Special colours not available
Side plates	Pre-painted galvanised steel	Polyester – painted white (RAL 9003 or RAL 9010, 20% gloss)	Special colours not available.
End plates	Pre-painted galvanised steel	Polyester – painted white (RAL 9003 or RAL 9010, 20% gloss)	Special colours not available
Supply air plenum	Galvanised steel		
Brackets	Galvanised steel		
Coil pipes	Copper		
Coil fins	Aluminium		

Accessories

Accessory / model	Code	Description	Note
Combined cooling and heating coil	TC = H	Coil with hot water circulation	Cooling/heating copper water pipe connections are Ø 15/10 mm

The Halton Rex 600 Basic's cooling/heating water pipe connections are Cu15/Cu10 with wall thickness of 0.9-1.0 mm fulfilling European Standard EN 1057:1996.

The maximum chilled/hot water circuit operating pressure is 1.0 MPa.
The supply air duct connection is 125 mm.

Function

The Halton Rex 600 Basic chilled beam is designed to be installed flush with a suspended ceiling.

The primary supply air enters the plenum of the active chilled beam. From there the air is diffused into the room through nozzles.

The supply air nozzle jets efficiently induce ambient room air, which is then directed horizontally along the ceiling surface. The secondary air is drawn through the perforation located at the bottom

of the beam. The air then cycled through the heat exchanger, where it is either cooled or heated before being diffused into the room.

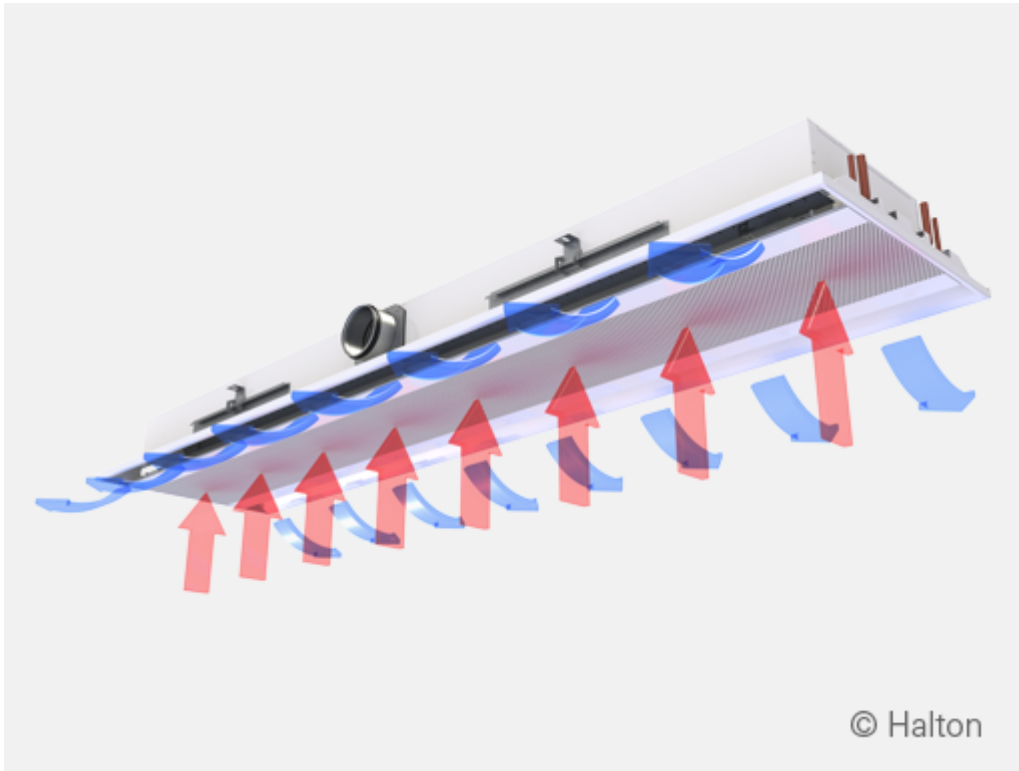

Installation

The Halton Rex 600 Basic active chilled beam is especially suitable for ceiling mounting running parallel to the exterior wall of the room.

When selecting the chilled beam orientation, the location of the supply air and water circuit connections are taken into account.

The chilled beam can be attached directly to the ceiling surface ($H1 = 195 \text{ mm}$) or suspended using threaded drop rods (8 mm). Each beam is equipped with movable brackets fixed to both sides of the beam. It is recommended that the brackets be positioned one quarter of the unit length ($L/4$) away from the end of the beam.

Install the main pipelines of the cooling and heating water circuits above the level of the chilled beam in order to enable venting of the pipework.

The duct connection is located at the middle of the long side. Handing of the unit can be changed on site by turning the heat exchanger.

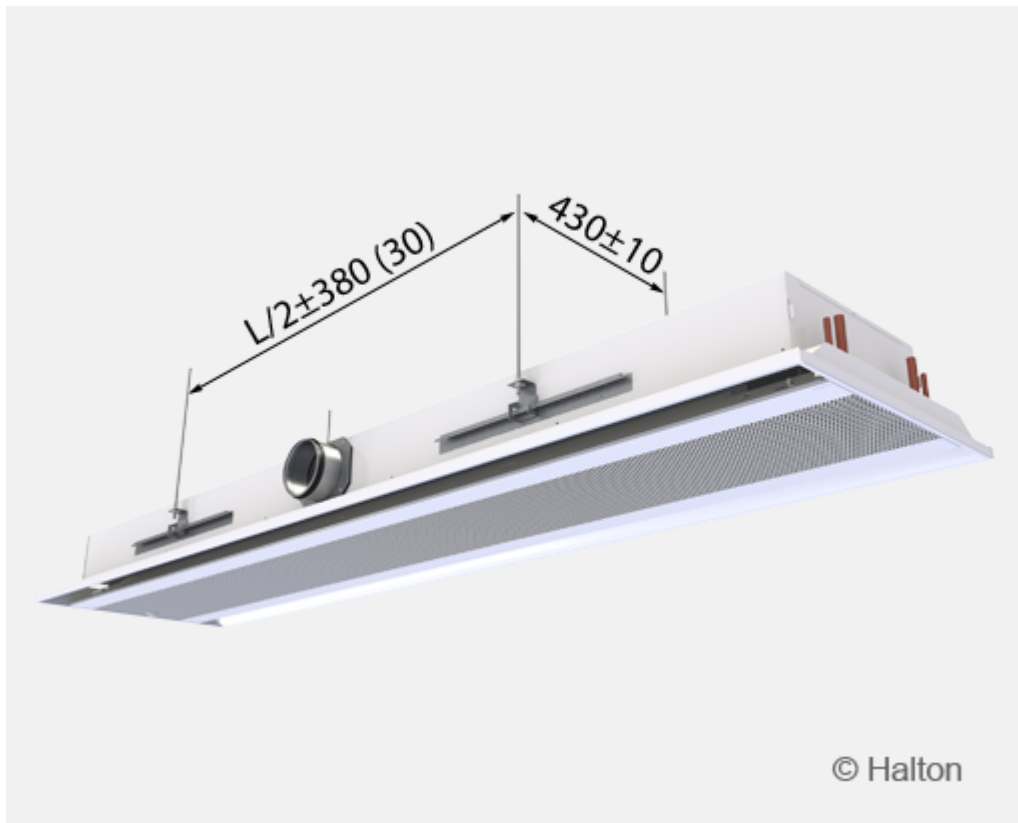

Adjustment

Cooling

The recommended cooling water mass flow rate is 0.02-0.10 kg/s, resulting in a temperature rise of 1-4 °C in the heat exchanger. To avoid condensation, the recommended inlet water temperature of the heat exchanger is over 14 °C.

Heating

The recommended heating water mass flow rate is 0.01-0.04 kg/s, resulting in a temperature drop of 5-15 °C in the heat exchanger. The maximum recommended temperature of the inlet water for the heat exchanger is 35 °C.

Balancing and control of water flow rates

Balance the water flow rates of the Halton Rex 600 Basic chilled beam with adjustment valves installed on the outlet side of the cooling and heating water loops. The cooling capacity and heating capacity of the chilled beam are controlled by regulating the water mass flow rate. The water mass flow rate can be controlled by using an ON/OFF valve or a two- or three-way proportional valve. Valves are not included to the delivery of the beams.

Adjustment of supply air flow rate

Connect a manometer in the measurement tap and measure the static pressure in the Halton Rex 600 Basic chilled beam. The air flow rate is calculated according to the formula below:

Nozzle jet air flow rate (q_v)

$$q_v = k * l_{\text{eff}} * \sqrt{\Delta p_m}$$

l_{eff} Length of the coil [m]

Δp_m Measured static chamber pressure [Pa]

Nozzle	k (l/s)	k (m3/h)
A	0,71	2,56
B	0,99	3,56
C	1,36	4,90
D	2,09	7,52
E	3,33	11,99

Servicing

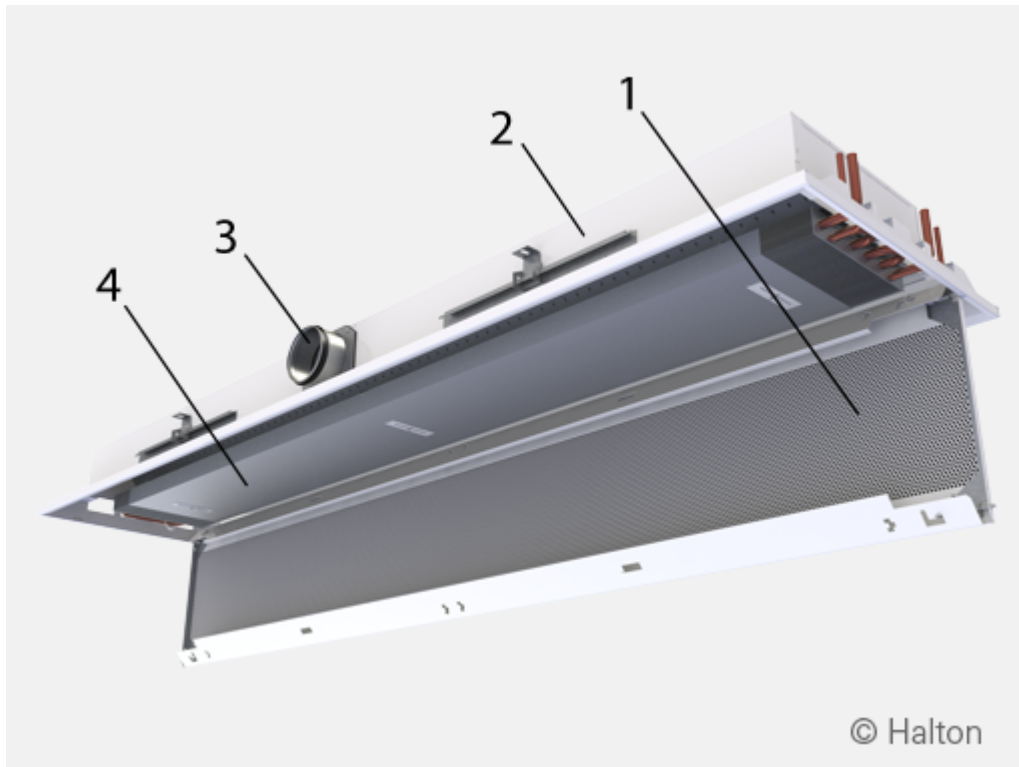

Code description:

1. Front panel
2. Casing
3. Supply air connection
4. Heat exchanger

Open the front panel (1) of the chilled beam. In beams longer than 2400 mm, the front panel can be opened in two sections.

Clean the supply air plenum and fins of the heat exchanger (4) with a vacuum cleaner, taking care not to damage the fins.

Clean the front panel and other visible painted plates using a damp cloth.

Specification

The active chilled beam has an integral recirculation air path through the perforated front panel. The front panel is openable from either side in order to allow general maintenance and cleaning. The front panel is removable without any special tools.

The active chilled beam is 595 mm wide and 195 mm high.

The active chilled beam has an inlet duct diameter of 125 mm.

Handing of the unit can be changed on site by turning around the heat exchanger

The frame, front, and side panels are made of galvanised steel plate.

All visible parts are white, painted to RAL 9003 or RAL 9010 (20% gloss).

All pipes are manufactured from copper, and connection pipes with a wall thickness of 0.9-1.0 mm.

The fins are manufactured from aluminium.

Optionally, heating is incorporated within the heat exchanger by means of two 10-mm pipes, connected in series.

All joints are soldered and factory pressure-tested.

The pipework's maximum operation pressure is 1.0 MPa.

The active chilled beam has a measurement tap to allow air flow measurement.

Active chilled beams are protected by a removable plastic coating.

The duct connection and pipe ends remain sealed during transport.

The active chilled beams are identified by labels attached to both the active chilled beam and the plastic packaging.

Product Code

R6B/S-L; LD-TC-CO-ZT

S = Nozzle type

- A Bi-directional/ Nozzle 1
- B Bi-directional/ Nozzle 2
- C Bi-directional/ Nozzle 3
- D Bi-directional/ Nozzle 4

E Bi-directional/ Nozzle 5

L = Total length

1200, 1800, 2400, 3000

Other options and accessories

LD = Duct connection / Duct size / Damper

L2N Left / 125 / Without damper

TC = Cooling / Heating functions (Coil type)

C Cooling

H Cooling and Heating

CO = Colour

SW Signal white (RAL9003)

W Pure white (RAL 9010)

X Special colour (RALxxxx)

ZT = Tailored product

N No

Y Yes (ETO)

Code example

R6B-A-3000, LD=L2N,TC=C,CO=SW,ZT=N