

MRVPLUS – Self Balancing Demand Controlled Ventilation (UL)

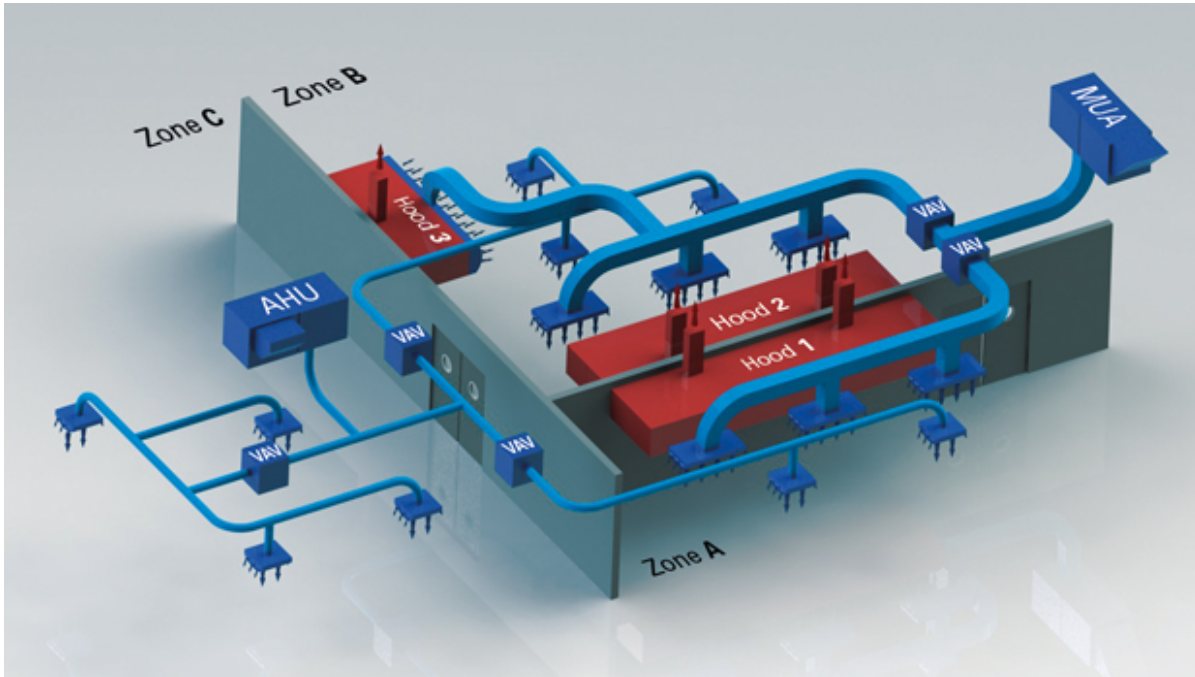

Overview

With Demand Control becoming the norm rather than the exception, managing the changes in exhaust volumes and building pressure has been a challenge. The M.A.R.V.E.L. system is unique among DCV systems as it measures exhaust rates in each hood in real time. This capability allows for an accurate signal for incoming replacement air ensuring space balance as the system varies the exhaust during operation.

As the majority of capture and containment problems occur due to high velocity discharge from replacement air diffusers, the next logical step was to design and supply a diffuser for commercial kitchen use that maximizes air flow rates while minimizing thermal plume disruptions. No longer will designers have to rely on office building type diffusers, but can select from a series of high volume, low velocity diffusers that are appropriate for general supply and remote zones in kitchens.

The system is self balancing and automatically adjusts exhaust air volumes and the appropriate makeup air requirement to each zone and/or hood and delivers it in a way that does not interfere with the cooking operation. For the first time ever the design team can provide a complete exhaust and air distribution system that is synchronized and encompasses all the design criteria needed to excel in the commercial kitchen setting.

Benefits & Features

- Provides Supply Air Zone Control with VAV terminal units (KVV-S or KVV-R) and KCD Kitchen Supply Diffusers

- Continually maintains space balance during variable exhaust volume
- Non Disruptive Air Distribution specifically designed for the kitchen space

Specification

Supply air shall be measured by Halton provided KVV terminal boxes for each zone to Halton hood mounted PSP MUA plenums or KCD diffusers as indicated on the equipment schedule and contract drawings. Control of VAV boxes is part of the M.A.R.V.E.L.+ Self-Balancing System. Interconnected wiring between hoods and KVV terminal boxes shall be provided in the field by appropriate contractor. Supply air quantities for individual zones are determined by the measured variable exhaust volume and ensure system balance at all times during variable volume operation.