

HMF – Einkanal-Kabinengerät



Overview

- Pressure range from 200 Pa up to 1000 Pa
- Airflow range 120 m³/h...500 m³/h
- 230 VAC ±10%, 50/60 Hz
- Inbuilt airflow measurement (pressure independent models)
- Damper min. / max. position settings (pressure dependent models)
- Triac controlled reheating coil(s), adjustable heating power (PWM) 0...100%
- Master/slave functionality: several cabin units can be controlled by one control panel
- Internal fuses included
- All parameters can be set onsite during commissioning by external device or preset at the factory
- All cable connections with fast connectors
- Easily tailored for different types of installations
- 90 °C safety switch with state detection and manual reset
- Minimum flow alarm (pressure independent model) and inbox temperature measurement with overheat limit to cut-off reheater power
- HMF cabin unit is supplied with control panel and interconnection cable
- MED approved for B-0/B-15 installations

Specification

Halton HMF is pressure independent (VAV/CAV) or pressure dependent (VAV) single duct cabin unit with integrated reheater. Pressure independent VAV or CAV operation is facilitated by continuous airflow measurement and damper regulation by intelligent controller. Pressure independent HMF adapts to variations in supply ductwork pressure levels and maintains individual fresh supply

airflow rate to each cabin. Pressure dependent VAV operation is facilitated only by damper regulation by intelligent controller. Pressure dependent HMF adapts to room temperature changes by regulating airflow between pre-set minimum and maximum damper positions.

Dimensions and Weight

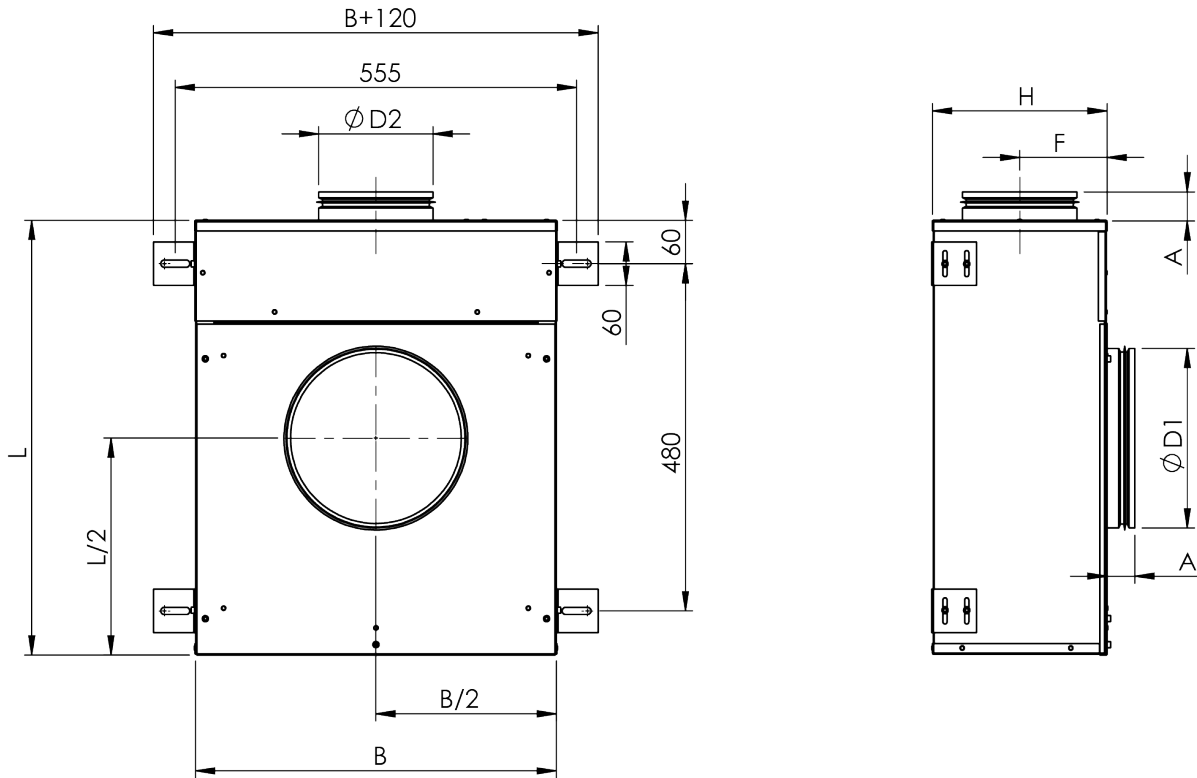

HMF DIMENSIONS, unit material thickness 0.5 mm

	L	B	H	F	A	$\varnothing D1$ male/ female	$\varnothing D2$ male
HMF-100	590	490	190	83	45	199/ 201	99
HMF-125	590	490	230	115	45	249/ 251	124
HMF-160	590	490	230	115	45	249/ 251	159

Note: male connection: outer dimension, female connection: inner dimensions. Note: Standard dimensions, modifications possible

HMF DIMENSIONS, unit material thickness 0.75/1.0 mm

	L	B	H	F	A	ØD1 male/ female	ØD2 male
HMF-100	600	500	200	88	40	199/ 201	99
HMF-125	600	500	240	120	40	249/ 251	124
HMF-160	600	500	240	120	40	249/ 251	159

Note: male connection: outer dimension, female connection: inner dimensions. Note: Standard dimensions, modifications possible

Material and Finishing

PART	MATERIAL	NOTE
Casing	Hot galvanized steel	Available as an option: stainless steel EN 1.4404 (AISI316L)
Casing thickness	0,5 mm	As an option: 0,75/1,0 mm
Spigots	Hot galvanized steel and EPDM rubber	Available as an option: stainless steel EN 1.4404 (AISI316L)
Insulation	Mineral wool, s=20 mm, MED approved	As an option: s=25 mm
I/O unit	Aluminium / plastic / electronics	–
Reheat coil	Stainless steel EN 1.4301 (AISI304)	–
Cables	Halogen free	–
Airflow measurement probes and tubes	Aluminium / polyurethane	–

Product Models and Accessories

HMF product options

- Pressure independent model (VAV/CAV)
- Pressure dependent model (VAV)
- Inputs for external switches such as balcony door and key card switches available as an option
- Network compatible with adapter for advanced energy efficiency and supervision system available as an option
- Energy efficiency functions to reduce unnecessary cooling / heating costs available as an option

Control panel features

Halton Marine HMF cabin units are available with three different control panel models; with rotating knob, push buttons with LED bar graph (available as option: IP54) and push buttons with LCD-display (available as option: IP54).

Common features

- Cabin temperature measurement
- Connector for bluetooth / communication adapter to set cabin parameters
- Software for parameter setting and trouble shooting
- Different colour options and custom labeling available as an option
- Delivered with IC-Cable (interconnection cable)
 - For control panel – cabin unit connection
 - Prefabricated with plugs on both ends
 - Cable plug on panel side is designed to be pulled through standard installation pipe
 - Halogen free and flame-retardant
 - Standard length 7 meters. Other lengths available.

Control panel with rotating knob

- Temperature adjustment by rotating knob

Control panel with push buttons and LED bar graph

- Temperature adjustment by push buttons
- Self diagnose function
- LED intensity control and auto dimming

Control panel with push buttons and LCD-display

- Temperature adjustment by buttons
- Self diagnose function
- LCD intensity control and auto dimming

- Display for actual and set point temperatures available as an option
- Time display available as an option
- A customized background picture available as an option
- Several frame options available

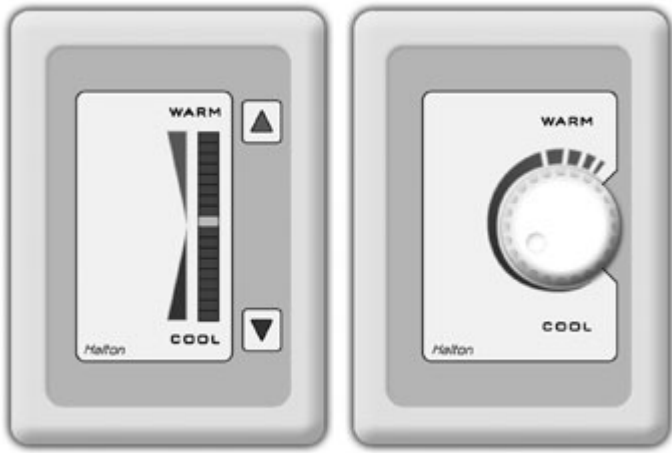

Control panel models; push buttons and rotating knob



LCD control panel

Cabin ventilation configuration table

	UNIT	HMM	HMM	HME	HME	HMF	HMF	HMF	HFR/M	HFR/M	HFR/M	HMR	HMR	HML
TERMINAL UNIT WITH JUNCTION BOX	CONTROL PACKAGE	K01	D03	K01	D03	M00	M01	M02	M00	M01	M02	D21	H21	B00
	Damper	manual	manual	manual	manual	electric	electric	electric	electric	electric	electric	electric	electric	electric
	Airflow measurement and control (VAV, CAV)	no	no	no	no	yes	no	yes	yes	no	yes	yes	yes	yes
	In-box temperature measurement	yes	yes	yes	yes	yes	yes	yes	yes	yes	yes	no	no	yes
	Reheater safety switch, manual reset	yes	yes	yes	yes	yes	yes	yes	yes	yes	yes	no	no	yes
	Safety switch state detection	no	yes	no	yes	yes	yes	yes	yes	yes	yes	no	no	yes
	Spare inputs (balcony door etc.)	no	no	no	no	yes	yes	yes	yes	yes	yes	yes	yes	yes
	Parameter setting by service tool	no	yes	no	yes	yes	yes	yes	yes	yes	yes	yes	yes	yes
CONTROL PANEL	Cabin temperature measurement	yes	yes	yes	yes	yes	yes	yes	yes	yes	yes	yes	yes	yes
	Controller with push buttons, 18 led bar	no	yes	no	yes	yes	no	no	yes	no	no	yes	no	yes
	Controller with knob	yes	no	yes	no	no	yes	yes	no	yes	yes	no	yes	no
	LCD room thermostat	no	optional	no	optional	optional	no	no	optional	no	no	optional	no	optional
	LED intensity control and auto dimming	no	yes	no	yes	yes	no	no	yes	no	no	yes	no	yes
	Self diagnose functionality	no	yes	no	yes	yes	no	no	yes	no	no	yes	no	yes
	Network compatible with adapter	no	yes	no	yes	yes	yes	yes	yes	yes	yes	yes	no	yes
	CO2 sensor available as an option	no	yes	no	yes	yes	no	no	yes	no	no	yes	no	yes
CABLES	Interconnection cable	IC4-X	IC6-X	IC4-X	IC6-X	IC6-X	IC6-X	IC6-X	IC6-X	IC6-X	IC6-X	IC6-X	IC6-X	IC6-X
	Master-Slave cable	MS4-X	MS2-X	MS4-X	MS2-X	MS2-X (MS5-X)	MS3-X	MS3-X	MS2-X (MS5-X)	MS3-X	MS3-X	MS2-X	MS3-X	MS2-X

Please note: HMM and HME units are also available without a control package.

Manually controlled airflows

Single duct units; HMM, HME

Pressure dependent units

Single duct units: HMF, HFR/M

Pressure independent units

Single duct units; HMF, HFR/M, HML

Dual duct units; HMR

Accessories for HMF cabin units

MS-Cable (master-slave cable)

- For master cabin unit – slave cabin unit/units connection
- Prefabricated with plugs on both sides
- Halogen free and flame-retardant
- Standard length is 7 meters. Other lengths available as an option.

Communication adapter

- Bluetooth communication to external device
- For wireless connection to set cabin unit parameters and trouble shooting

Network adapters

- Network adapter (also available as WiFi) expands a stand-alone unit to network compatible unit (LON or Ethernet network)
- Enables supervision and advanced energy efficiency functions
- For more information, see Halton Networks for cabin ventilation -brochure or contact Halton Marine Sales office.

Reheaters available

- Standard reheaters: 400W, 800W, 400+800W, 1200W, 1500W, 1800W
- Offshore reheaters: 400W, 800W, 1200W, 1600W (surface temperature below 90°C on operating airflow)

Practical power level may be software adjusted cabin by cabin. Cable and power supply design has to be done according to maximum available heating power.

Function

Control panel includes also a number of special features such as diagnostics function, room brightness measurement and re-programmability. The power supply and data transfer between cabin unit and control panel is carried out via interconnection cable. Temperature range is software adjustable between 10 and 30°C.

FUNCTION OF VAV UNIT

When passenger demands lower temperature by using control panel unit, the damper opens in order to increase the flow of cold air towards the maximum value. When the required temperature in the cabin is achieved, the damper reference is held until the temperature demand changes. In heating mode, the damper restricts the airflow towards its minimum rate, and if the required

temperature in the cabin is not thus achieved, the controller activates the electric reheater inside the unit in a stepless manner.

Regulation diagram, VAV

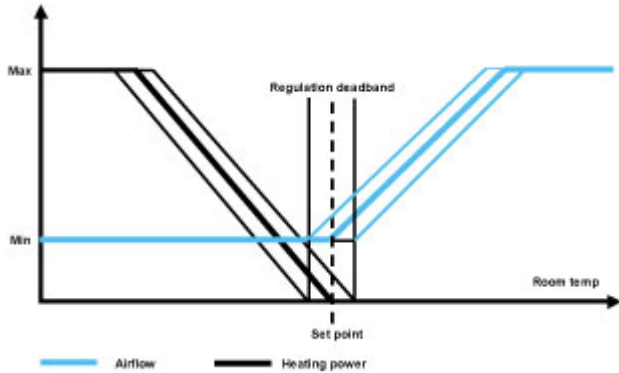

FUNCTION OF CAV UNIT

Airflow is kept in pre-set level in any condition. When passenger demands for a higher temperature by using control panel, the electric reheater inside the cabin unit will be activated in a stepless manner towards to maximum heating capacity or until desired temperature is achieved. When passenger demands for a lower temperature by using control panel, the electric reheater inside the unit will be deactivated in a stepless manner towards to zero heating capacity or until desired temperature is achieved.

Regulation diagram, CAV

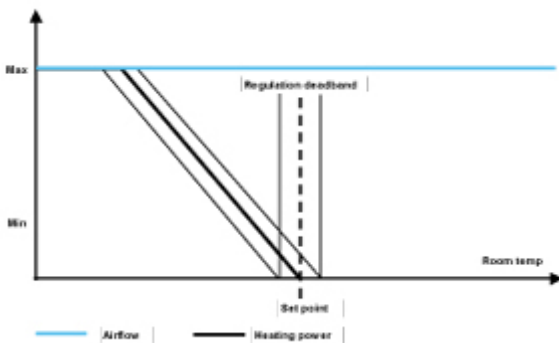

Operating range for HMF

HMF-100	HMF-125
120 m ³ /h – 350 m ³ /h	150 m ³ /h – 500 m ³ /h

Cabin unit's airflow measurement accuracy

	AIRFLOW (m ³ /h)				
	120-150	151-200	201-300	301-400	401-500
Accuracy*	±20%	±15%	±10%	±8%	±6%

*) ductwork pressure 200-1000 Pa (optimal)

Note: When comparing airflow measurements between cabin unit and other device, cabin unit's airflow regulation dead-band has to be taken into account ($\pm 10 \text{ m}^3/\text{h}$).

Installation

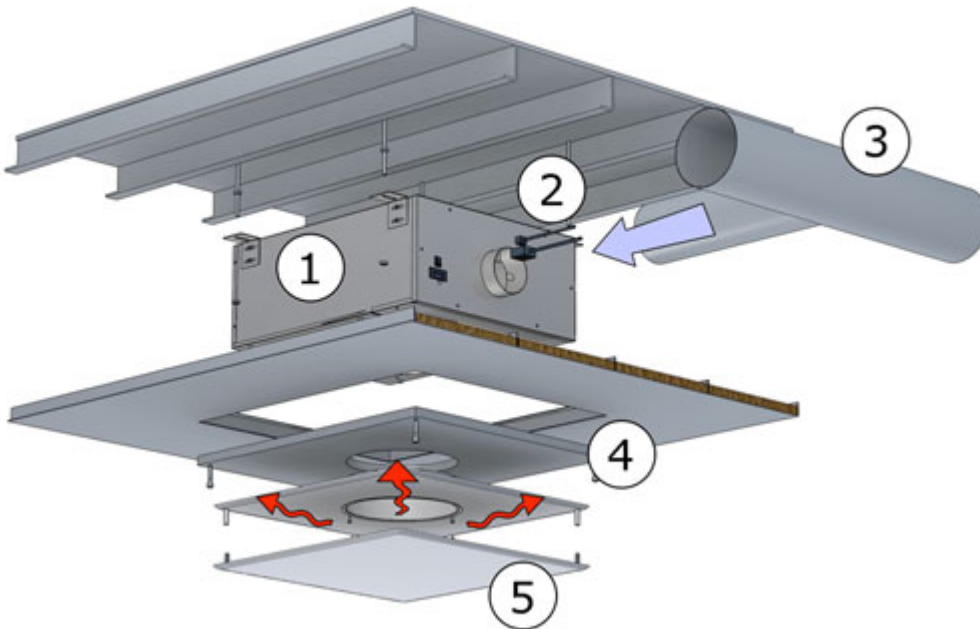

Cabin unit mounting instruction

Projects requirements and possibilities should be taken into account when designing the installation. For more information on the possibilities contact Halton Marine sales office.

Main principles in cabin unit installation:

1. Fix cabin unit above false ceiling using thread bar (as seen on picture) or frame installation
2. Connect power supply and IC cable to the unit. (cable installation should be done before this phase, see Interconnection Cable Mounting Instructions). As standard cabin unit has Ensto NAC 31 plug for the power supply (counterpart NAC 32 not include).
3. Connect supply air ducts to cabin unit inlets.
4. Close maintenance / installation hatch.
5. Connect and assemble diffuser to the cabin unit outlet.

Control Panel mounting instruction

1. Install LRC-1 CP unit back plate to the provided leveled place on the wall.
2. Fasten 3 screws (DIN 7981 or similar, max. head height 3mm) to fix CP unit to its place.
3. Connect LRC-1 interconnection cable to the interconnection connector. Max. allowed tractive force is 30 N.
4. Install LRC-1 CP unit front plate to the back plate
5. Fasten the screw in the bottom carefully. Max. Torque 0,3 Nm.

The LRC-1 CP unit should be positioned on the wall inside the room it will regulate. It is advised to avoid direct sunlight or position near heating/cooling source object.

Interconnection Cable mounting instructions

Interconnection cable comes prefabricated with plugs on both sides. To install, draw it through the provided tube from cabin unit to CP unit (the plug on CP unit is small enough to allow drawing through tubes). Max. allowed tractive force is 30N. On the CP side, in the room, leave approximately 8 cm of the cable (the wires) outside the tube. The near end of the tube (CP-unit side) must be blocked (e.g. foam) to prevent condensation and thermal transfers reaching CP unit.

Safety distances

A required safety distance as illustrated must be taken into account when installing the cabin unit. Airflow measurement accuracy cannot be guaranteed if safety distance is not taken into account.

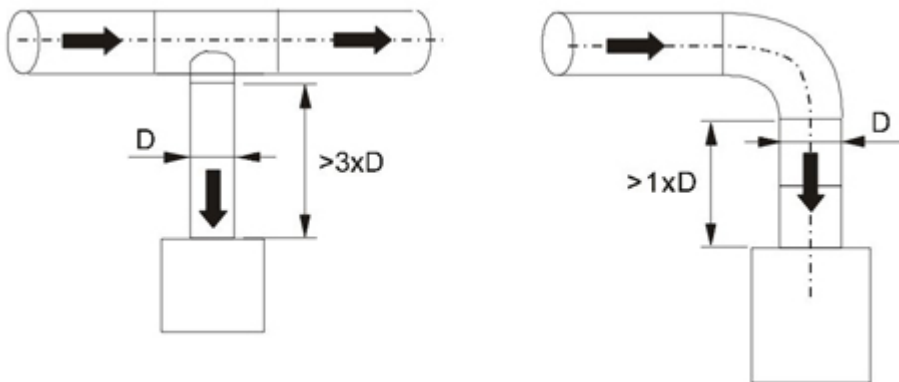

Commissioning

All parameters can be preset at the factory according to order. During commissioning all parameters can be modified wirelessly with portable device using LRC manager software.

Halton also provides supervision and commissioning services for the projects.

For more information contact Halton Marine Sales office.

Weights

Casing thickness	HMF-100	HMF-125
0,5 mm	11	11,5
0,75/1,0 mm	17	18

Product Code

(C)=Diameter of inlet connection

100
125

(E)=Diameter of outlet connection

160
200
250

(C2)=Outlet connection type

(A) Male with gasket
(B) Male without gasket
(C) Female

(CP)=Location of Power Supply Connection

(F) Front end
(B) Back end
(S) Side

(CU)=Control Unit

(B1) B00 (pressure independent, automatic)
(M0) M00 (pressure independent, automatic)
(I1) I00 (pressure dependent, semiautomatic)

(RH)=Reheat Coil

(NA) No reheater
(S1) Single coil 400 W
(S2) Single coil 800 W
(S3) Single coil 1200 W
(S4) Single coil 1500 W
(S5) Single coil 1800 W
(D1) Double coil 400 W + 800 W

Code example

HMF-125-160,C2=A,CP=B,CU=B1,RH=S1,ZT=Y

Sound Attenuation

Sound attenuation (dB)

	f(Hz)	63	125	250	500	1000	2000	4000	8000
HMF-100	Ω L(dB)	6,4	11,3	15,9	25,8	34,8	37,9	35,3	34,7
HMF-125	Ω L(dB)	4,9	9,6	16,2	24,9	33,4	36,8	35,4	35,6

Ω L: Sound attenuation not including end reflection