

Halton Ivo ITC – Pressure relief damper

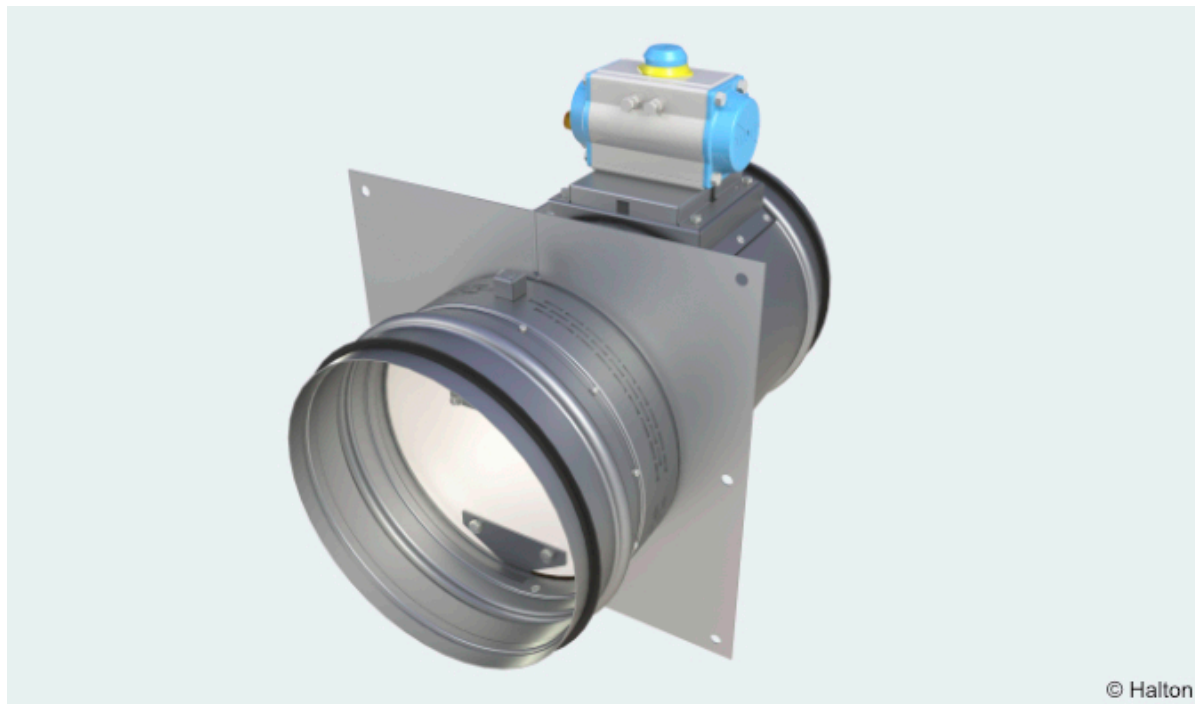

Overview

The Halton Ivo ITC pressure relief damper, a reliable evolution of the EI120S fire damper, is marked and tested according to its respective standards. It is fire-resistant and provides insulation with low smoke leakage. In normal mode, it is closed and opens in an extinguishing situation to release excess pressure. This circular duct product can be installed horizontally or vertically in concrete, masonry, and lightweight structures, providing a reliable solution for your safety needs.

Application areas

- Buildings
- IT facilities
- Archives

Key features

- All units are factory tested to guarantee performance
- Operating pressure 6 bar (factory setting)
- Supply pressure max. 60 bar
- Closing pressure 300 Pa
- Actuator ATEX certified
- The structure is based on a CE-marked fire damper
- Sizes from 160 up to 630 mm are available
- >Designed for use with gas extinguishing systems

- Suitable for use in demanding conditions

Operating principle

The pressure relief damper Halton Ivo ITC, based on the EI120 fire damper, is a reliable unit equipped with a pneumatic actuator and pressure reducer. Upon activation of the gas extinguishing system, the pneumatic actuator opens the damper, reducing the pressure level inside the room. Once the pressure is balanced, the spring inside the pneumatic actuator closes the damper, demonstrating its dependable functionality.

- The pressure relief damper is closed in normal mode and opens in an extinguishing situation to remove excess pressure from space.
- After the extinguishing situation, the pressure relief damper closes to the closed position with the help of a mechanical spring.
- Halton recommends performing a functional test of the gas extinguishing system before commissioning the premises.

This pressure relief damper is a vital part of the automatic gas extinguishing system to release excess gas from space and to avoid any damage to building construction due to high pressure.

IT facilities and special facilities such as archives use gas extinguishing systems. Damage to data and assets from these facilities poses serious consequences, as they might interrupt operations or be destroyed. Hence, these automatic gas extinguishing systems, which extinguish gases such as argon, other inert gases, CO₂, and Novec, often protect such facilities.

Features and options

Feature	Description
Pneumatic actuator	Spring return and pressure reducer
Size	Ø160 - Ø630 mm
Weight	6.2 - 26.8 kg
Pressure difference in ducts	1200 Pa
Integrated installation frame	Galvanised steel (Stainless steel option available)

Structure and materials

Fig. 1. Halton Ivo ITC structure

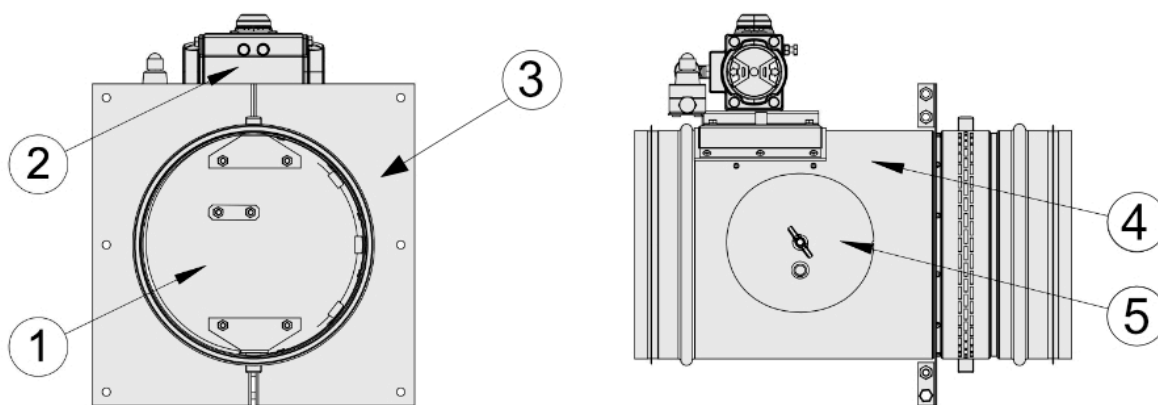

No.	Part	Material	Note
1	Blade	Asbestos free boards made of mineral fiber	-
2	Operating model (actuator)	-	Pneumatic, including pressure reducer.
3	Frame	Galvanised steel	Stainless steel options available on request
4	Casing	Galvanised steel	Stainless steel options available on request
5	Inspection hatch covering	Galvanised steel	Stainless steel, when casing also stainless

Dimensions and weight

Fig. 2. Halton Ivo ITC dimensions

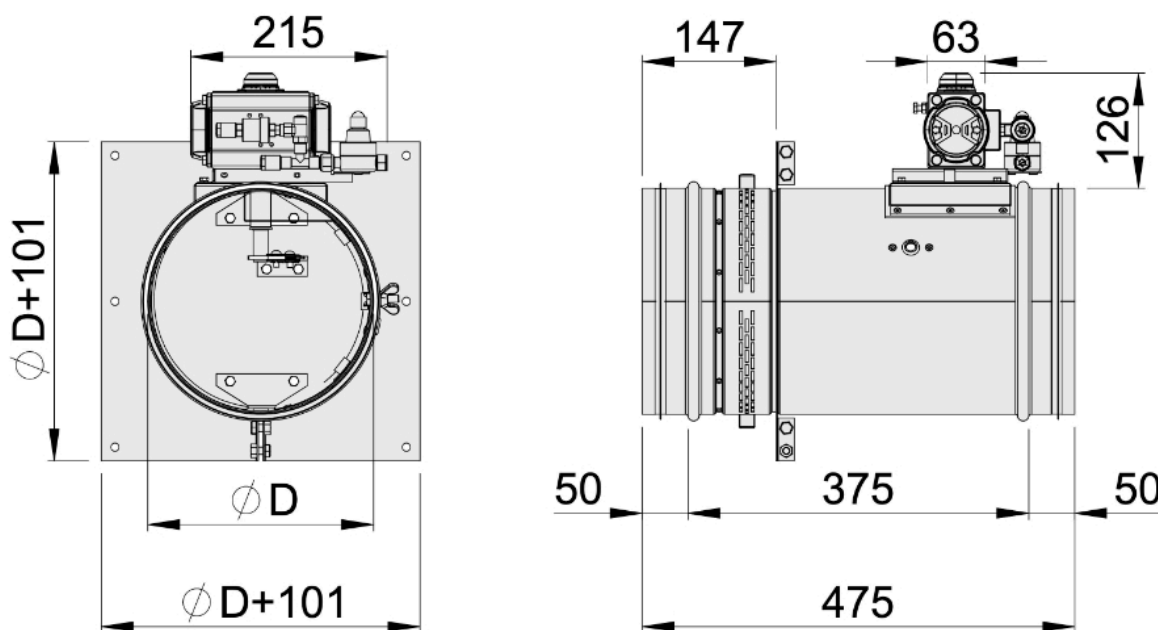

Duct size [mm]	Weight [kg]
160	6.2
200	8.3
250	9.3
315	11.2
355	13.2
400	15.1
500	20.0
630	26.8

Specification

The pressure relief damper Halton Ivo ITC, based on the EI120 fire damper, is a reliable unit equipped with a pneumatic actuator and pressure reducer. Its structure is based on a CE-approved fire damper and ATEX-approved actuator. It is tested according to CE certification standards EN15650 and EN 1366-2 for fire testing as a fire damper.

Construction

- The in-wall installation allows for the installation of the spindle of the blade at any position (360°).
- In concrete, masonry and lightweight structures, you can install fire dampers in both vertical and horizontal positions.
- Leakage through closed damper blade fulfils EN 1751 class 2
- The casing complies with the tightness requirements for EN 1751 class C. According to EN 1751, leakage through a closed damper blade fulfils class 2.
- It can be installed away from the separate element up to 1.0 metre, fulfilling fire resistance classes up to EI 90 (v_e h_o i ↔ o) S.
- A maximum fire resistance class EI 120 (v_e h_o i ↔ o) S requirements.

Material

- The casing complies with the tightness requirements for EN 1751 class C. According to EN 1751, leakage through a closed damper blade fulfils class 2.
- Galvanised or stainless steel (AISI 316L) casing, with the blade made of fire-resistant and asbestos-free boards (mineral fibre).
- Equipped with one inspection hatch, which allows you to check the position of the damper blade.

Accessories

- No spare parts or additional installation frames are needed, regardless of the installation method.

Standards

There is no harmonized product standard for pressure relief dampers.

The structure of this damper is based on for CE-approved fire damper and ATEX-approved actuator, with the exception that this is opened with inert gas release (extinguishing gas displaces oxygen) in connection with overpressure to lead away, e.g. ATK in device mode.

Complies with ventilation of building standard EN 15650 (CE)

The basis of this product complies with the following standards:

Performance/processes	Standard
Fire classification (EI 120 (v _e h _o i↔o) S, EI 90 (v _e h _o i↔o) S, EI 60 (v _e h _o i↔o) S)	EN 13501-3+A1 standard
Fire testing	EN 1366-2
Construction Products Regulation (CPR)	1391-CPR-2018/0202
Declaration of Performance (DoP)	10033-ESC-2019/01/01
Leakage through closed damper blade fulfils class 2	EN 1751
Damper casing tightness class C	EN 1751
Corrosion resistance (Salt mist test)	EN 60068-2-52

Installation

Suitable for both vertical (wall) and horizontal (ceiling/floor) mounting. The damper's blade spindle can be positioned at any angle (360°) during wall installation, allowing for greater flexibility. Capable of being installed up to 1.0 meters away from the main structure while maintaining a fire resistance of EI 90 S.

Fire resistance classification:

- Certified for use in concrete, masonry, or lightweight structures.
- Complies with fire resistance classes EI 120, EI 90, or EI 60.
- Fully CE marked for adherence to safety and quality standard.

To ensure optimal performance, a minimum amount of free space must be left around the damper's body during installation.

No spare parts or additional installation frames are needed, regardless of the installation method.

Note: More detailed information can be found in the Installation Guide for this fire damper. You can download it from the "Downloads" section, when available.

Servicing

No regular maintenance is required for the product.

Inspection must be carried out regularly according to local building codes, to ensure proper operation of fire dampers. The **minimum recommended inspection period is every 6 months**. Save the documentation of testing needs for future needs.

The fire damper is equipped with one inspection hatch, enabling the possibility to check the position of the damper blade. The actuator includes position indicators, open and close.

Upon failure during testing of the fire damper, maintenance service shall order from an authorised Halton representative to ensure appropriate operation of the product.

Order code

ITC-D; MA-AC-ZT

Main options	
D = Duct connection size [mm]	160, 200, 250, 315, 355, 400, 500, 630
Other options and accessories	
MA = Material	
GS	Galvanised steel
AC = Accessories	
NA	Not assigned
N2	Safety mesh in both ends
ZT = Tailored product	
N	No
Y	Yes (ETO)
Order code example	
ITC-160; MA=GS, AC=NA, ZT=N	